

CHAPTER 1 DEFINITIONS AND INTERPRETATION

PART A - DEFINITIONS

1.01 Definitions

In these Requirements, unless the context otherwise requires -

admission	means admission of securities to the Official List of the Exchange and “admitted” will be construed accordingly.
adviser	in relation to a listed issuer, means – <ul style="list-style-type: none"> (a) a person who is permitted to carry on the regulated activity of advising corporate finance under the CMSA, which includes a Principal Adviser; (b) a financial adviser, lawyer, accountant, valuer, or any other person retained by a listed issuer to provide professional advice or services in relation to a matter governed by these Requirements; or (c) any other person who, acting in the capacity of an adviser, presents, submits or discloses an application, a circular or any other document to the Exchange on behalf of an applicant or a listed issuer.
amendment	in relation to a document or information, includes any addition, deletion, modification or variation of any part of such document or information, and “amended” will be construed accordingly.
applicant	means a person who is applying for admission of securities.
approved accounting standards	in relation to the Malaysian Accounting Standards Board (MASB), has the meaning given in section 2 of the Financial Reporting Act 1997.
articles of association	includes any document defining the constitution or governing the activities or conduct of an applicant, a listed corporation or its members.
associate	in relation to a director, shareholder, substantial shareholder, or substantial unit holder, <u>or</u> substantial securities holders, of an applicant or a listed issuer (individually and collectively referred to as “ Associated Party ”) means a person who falls under any one of the following categories: <ul style="list-style-type: none"> (i) a family member of the Associated Party; (ii) a trustee of a trust (other than a trustee for an employee share scheme or pension scheme) under which the Associated Party or a family member of the Associated Party is the sole beneficiary; (iii) a person who is accustomed or under an obligation, whether formal or informal, to act in accordance with the directions, instructions or wishes of the Associated Party;

	(iv)	a person in accordance with whose directions, instructions or wishes the Associated Party is accustomed or is under an obligation, whether formal or informal, to act;
	(v)	a body corporate or its directors which/who is/are accustomed or under an obligation, whether formal or informal, to act in accordance with the directions, instructions or wishes of the Associated Party;
	(vi)	a body corporate or its directors whose directions, instructions or wishes of which, the Associated Party is accustomed or under an obligation, whether formal or informal to act;
	(vii)	a body corporate in which the director, shareholder or a family member of the Associated Party is entitled to exercise, or control the exercise of, not less than 15% of the votes attached to voting shares in the body corporate; or
	(viii)	a body corporate which is a related corporation.
associated company		has the meaning given to “ associate ” under the accounting standards issued or adopted by the Malaysian Accounting Standards Board.
Board		in relation to the Exchange, means the board of directors of the Exchange.
board lot		in relation to any securities quoted on the Official List, means a parcel of securities comprising 100 units or any other number of securities permitted by the Exchange to be traded on the stock market.
books closing date		means the specified time and date set by a listed issuer for the purpose of determining entitlements to dividends, interests, new securities or other distributions or rights of holders of its securities.
Cash Company		means a listed issuer whose assets on a consolidated basis, consist of 70% or more of cash or short term investments, or a combination of both, who has been considered by the Exchange as a Cash Company under paragraph 8.03.
change in the board of directors		in relation to a listed corporation, means a change within a 12-month period from the date of the acquisition in –
	(a)	at least one-half of the membership of the board of directors of the listed corporation; or
	(b)	at least one-third of the membership of the board of directors of the listed corporation, including the chief executive.
chief executive		in relation to a corporation, means the principal executive officer of the corporation for the time being, by whatever name called, and whether or not he is a director.
closed-end fund		means an applicant or a listed corporation which is engaged wholly in the business of investing its funds in securities for the purposes of -
	(a)	spreading investment risks; and

	(b) managing a portfolio of investments ³ ;
	to gain revenue and profit for the benefit and on behalf of its shareholders.
CMSA	means the Capital Markets and Services Act 2007.
collective investment scheme	means any arrangement where –
	(a) it is made for the purpose, or having the effect, of providing facilities for persons to participate in or receive profits or income arising from the acquisition, holding, management or disposal of securities, futures contracts or any other property (“ scheme’s assets ”) or sums paid out of such profits or income;
	(b) the persons who participate in the arrangements do not have day-to-day control over the management of the scheme’s assets; and
	(c) the scheme’s assets is <u>are</u> managed by an entity who is responsible for the management of the scheme’s assets and is approved/authorised/licensed by a relevant regulator to conduct fund management activities,
	and includes among st others real estate investment trusts and exchange-traded funds.
completion of qualifying acquisition	in relation to a SPAC, means the point of time where all conditions precedent set out in the sale and purchase agreement governing the qualifying acquisition have been fulfilled, and “complete the qualifying acquisition” will be construed accordingly.
controlling shareholder	means any person who is or a group of persons who together are entitled to exercise or control the exercise of at least 33% of the voting shares in a company (or such other percentage as may be prescribed in the Take-Overs and Mergers Code as being the level for triggering a mandatory general offer) or who is or are in a position to control the composition of a majority of the board of directors of such company.
convertible securities	means securities which are convertible or exercisable, by their terms of issue, into listed shares.
core business	means the business which provides the principal source of operating revenue or after-tax profit to a corporation and which comprises the principal activities of the corporation and its subsidiary companies.
corporation	has the meaning given in section 2(1) of the CMSA.
custodian	in relation to a Trust Account for a SPAC, means -
	(a) a trust company registered under the Trust Companies Act 1949 or incorporated pursuant to the Public Trust Corporation Act 1995 and is in the List of Registered Trustees in relation to Unit Trust Funds issued by the SC; or
	(b) a licensed bank or merchant bank as defined in the Banking

		and Financial Institutions Act 1989, which is independent of the SPAC's adviser and management team.
debt securities		means debentures, loan stocks or other similar instruments representing or evidencing indebtedness, whether secured or unsecured, and whether convertible or not.
deposited security		means a security standing to the credit of a securities account and includes a security in a securities account that is in suspense.
depositor		means a holder of a securities account established by the Depository.
Depository		means Bursa Malaysia Depository Sdn Bhd.
depository bank		in relation to depository receipts, means the issuer of such depository receipts.
depository receipt		means a security which accords a right to the registered holder to own a prescribed quantity of securities listed on a Recognised Stock Exchange.
director		has the meaning given in section 2(1) of the CMSA and includes in the case of an issuer of structured warrants or a listed issuer which is a collective investment scheme, a director of the issuer of the structured warrants or a director of a management company of the collective investment scheme respectively.
Exchange		means Bursa Malaysia Securities Berhad.
Exchange Company	Holding	means Bursa Malaysia Berhad.
exchange-traded fund		means a listed index-tracking fund structured as a collective investment scheme <u>or any other approved structure</u> whose primary objective is to achieve the same return as a particular market index by investing all (full replication) or substantially all (strategic sampling) of its assets in the constituent securities of the index returns that correspond to the performance of a particular index.
expert		includes an engineer, valuer, accountant and any other person whose profession gives authority to a statement made by him.
family		in relation to a person means such person who falls within any one of the following categories: <ul style="list-style-type: none"> (a) spouse; (b) parent; (c) child including an adopted child and step-child; (d) brother or sister; and (e) spouse of the person referred to in subparagraphs (c) and (d) above.
foreign corporation		means an entity that is incorporated outside Malaysia.

independent adviser or expert	means an adviser or an expert who is independent of the management and board of directors of the applicant or listed issuer which appoints it and free from any business or other relationship which could interfere with the exercise of independent judgement by such adviser or expert.
independent director	<p>means a director who is independent of management and free from any business or other relationship which could interfere with the exercise of independent judgement or the ability to act in the best interests of an applicant or a listed issuer. Without limiting the generality of the foregoing, an independent director is one who -</p> <p>(a) is not an executive director of the applicant, listed issuer or any related corporation of such applicant or listed issuer (each corporation is referred to as "said Corporation");</p> <p>(b) has not been within the last 2 years and is not an officer (except as a non-executive director) of the said Corporation. For this purpose, "officer" has the meaning given in section 4 of the Companies Act 1965;</p> <p>(c) is not a major shareholder the said Corporation;</p> <p>(d) is not a family member of any executive director, officer or major shareholder of the said Corporation;</p> <p>(e) is not acting as a nominee or representative of any executive director or major shareholder of the said Corporation;</p> <p>(f) has not been engaged as an adviser by the said Corporation under such circumstances as prescribed by the Exchange or is not presently a partner, director (except as an independent director) or major shareholder, as the case may be, of a firm or corporation which provides professional advisory services to the said Corporation under such circumstances as prescribed by the Exchange; or</p> <p>(g) has not engaged in any transaction with the said Corporation under such circumstances as prescribed by the Exchange or is not presently a partner, director or major shareholder, as the case may be, of a firm or corporation (other than subsidiaries of the applicant or listed issuer) which has engaged in any transaction with the said Corporation under such circumstances as prescribed by the Exchange.</p>

[Cross reference: Practice Note 13]

infrastructure project	means a project which creates the basic physical structures or foundations for the delivery of essential public goods and services that are necessary for the economic development of a state, territory or country, such as the construction and operation of roads, bridges, tunnels, railways, mass transit systems, seaports, airports, water and sewage systems, sewerage systems, power plants, gas supply systems and telecommunication systems.
infrastructure project corporation	means a corporation whose core business is building and operating an infrastructure project.

listed	means admitted to the Official List and not removed, and “ listing ” will be construed accordingly.
listed corporation	means a corporation whose securities or any class of its securities have been admitted to the Official List and not removed.
listed issuer	means any one or more, as the context may require, of the following: <ul style="list-style-type: none"> (a) a listed corporation, including a SPAC; (b) a listed collective investment scheme; or (c) an issuer of any other listed securities.
major associated company or major subsidiary	means an associated company or subsidiary, as the case may be, which contributes 70% or more of the profit before tax or total assets employed of the listed issuer on a consolidated basis.
major shareholder	means a person who has an interest or interests in one or more voting shares in a corporation and the nominal amount of that share, or the aggregate of the nominal amounts of those shares, is - <ul style="list-style-type: none"> (a) 10% or more of the aggregate of the nominal amounts of all the voting shares in the corporation; or (b) 5% or more of the aggregate of the nominal amounts of all the voting shares in the corporation where such person is the largest shareholder of the corporation. <p>For the purpose of this definition, “interest in shares” has the meaning given in section 6A of the Companies Act 1965.</p>
management company	means a company by which or on whose behalf a unit of a collective investment scheme – <ul style="list-style-type: none"> (a) has been or is proposed to be issued or offered for subscription or purchase; or (b) in respect of which an invitation to subscribe or purchase has been made, <p>and includes any person for the time being exercising the functions of the management company.</p>
management team	in relation to a SPAC, includes the members of the board of directors (but excludes independent directors) and employees of the SPAC who exercise significant influence in making strategic decisions in the SPAC.
Managers	in relation to a closed-end fund, means collectively – <ul style="list-style-type: none"> (a) such company incorporated in Malaysia; and (b) individual(s), <p>responsible for managing the investments of closed-end fund as approved by the SC under the SC’s Guidelines for Public Offerings of</p>

	Securities of Closed-end Funds.
market day	means a day on which the stock market of the Exchange is open for trading in securities.
member	includes a depositor who will be treated as if he were a member pursuant to section 35 of the Securities Industry (Central Depositories) Act 1991 but excludes the Depository in its capacity as a bare trustee.
net assets	refers to the net assets attributable to ordinary equity holders of the listed issuer.
officer	(a) in relation to an applicant, listed issuer or its related corporation, means the chief executive, the chief operating officer, the chief financial controller or any other person primarily responsible for the operations or financial management of an applicant, listed issuer or its related corporation, by whatever name called; and (b) in relation to the Exchange or the Exchange Holding Company, has the meaning given in section 4 of the Companies Act 1965.
Official List	means a list specifying all securities listed on the <u>Main Market of the Exchange</u> .
options	includes options under a share scheme for employees, convertible securities and any other types of options in respect of the issued or unissued securities of a corporation.
Participating Organisation	means a company which carries on the business of dealing in securities and for the time being recognised as a Participating Organisation of the Exchange pursuant to the Rules of the Exchange.
partner	in relation to a director, major shareholder, or a person connected with the director or major shareholder, means such person who falls within any one of the following categories: (a) a person with whom the director, major shareholder or person connected with the director or major shareholder, is in or proposes to enter into partnership with. “Partnership” for this purpose has the meaning given in section 3 of the Partnership Act 1961; and (b) a person with whom the director, major shareholder or person connected with a director or major shareholder has entered or proposes to enter into a joint venture, whether incorporated or not.
Permitted Investments	in relation to a SPAC, means investments in securities issued by the Malaysian government, money market instruments and AAA-rated papers.
person	includes a body of persons, corporate or unincorporate (including a trust).
person connected	in relation to a director, major shareholder or in relation to a SPAC, a

member of the management team, means such person who falls under any one of the following categories:

- (a) a family member of the director, major shareholder or management team member;
- (b) a trustee of a trust (other than a trustee for an employee share scheme or pension scheme) under which the director, major shareholder, management team member, or a family member of the director, major shareholder or management team member, is the sole beneficiary;
- (c) a partner of the director, major shareholder, management team member, or a partner of a person connected with that director, major shareholder or management team member;
- (d) a person who is accustomed or under an obligation, whether formal or informal, to act in accordance with the directions, instructions or wishes of the director, major shareholder or management team member;
- (e) a person in accordance with whose directions, instructions or wishes the director, major shareholder, or management team member is accustomed or is under an obligation, whether formal or informal, to act;
- (f) a body corporate or its directors which/who is/are accustomed or under an obligation, whether formal or informal, to act in accordance with the directions, instructions or wishes of the director, major shareholder or management team member;
- (g) a body corporate or its directors whose directions, instructions or wishes the director, major shareholder or management team member is accustomed or under an obligation, whether formal or informal, to act;
- (h) a body corporate in which the director, major shareholder, or management team member, or persons connected with him are entitled to exercise, or control the exercise of, not less than 15% of the votes attached to voting shares in the body corporate; or
- (i) a body corporate which is a related corporation.

PN17 Company has the meaning given in paragraph 8.04.5;

predominantly foreign-based operations means a situation where –

- (a) the after-tax profits of ~~an applicant~~the corporation derived from assets or operations held outside Malaysia are higher than the after-tax profits derived from assets or operations held within Malaysia; or
- (b) the majority of the infrastructure projects of the corporation are located outside Malaysia.

predominantly Malaysian-based means a situation where –

operations	<p>(a) the after-tax profits of the corporation an applicant derived from assets or operations held within Malaysia are higher than the after-tax profits derived from assets or operations held outside Malaysia; or</p> <p>(b) the majority of the infrastructure projects <u>of the corporation</u> are located within Malaysia.</p>
primary listing	means admission to the Official List on a primary basis.
Principal Adviser	has the meaning given in the SC's Principal Adviser Guidelines.
promoter	includes a controlling shareholder, a person connected with a controlling shareholder and an executive director who is a substantial shareholder of an applicant or listed issuer.
public	<p>(a) in relation to a corporation, means all persons or members of the public but excludes -</p> <p style="margin-left: 20px;">(i) directors of an applicant or a listed issuer and its subsidiaries;</p> <p style="margin-left: 20px;">(ii) substantial shareholders of an applicant or a listed issuer except where such a shareholder fulfils all the following requirements in which case such shareholder may be included as a "public" shareholder:</p> <p style="margin-left: 40px;">(aa) such shareholder's interest, directly or indirectly is not more than 15% of the total number of shares of the applicant or listed issuer;</p> <p style="margin-left: 40px;">(bb) such shareholder is not a promoter of the applicant or listed issuer; and</p> <p style="margin-left: 40px;">(cc) such shareholder is either -</p> <p style="margin-left: 60px;">(A) a statutory institution who is managing funds belonging to contributors or investors who are members of the public; or</p> <p style="margin-left: 60px;">(B) an entity established as a collective investment scheme, such as closed-end funds, unit trusts or investment funds (but excluding investment holding companies);</p> <p style="margin-left: 20px;">(iii) associates of directors or substantial shareholders of an applicant or a listed issuer;</p> <p>(b) in relation to a closed-end fund, has the same meaning as the definition of "public" in relation to a corporation but excludes -</p> <p style="margin-left: 20px;">(i) <u>Managers of the closed-end fund</u>;</p> <p style="margin-left: 20px;"><u>(ii)</u> directors of <u>the</u> Managers;</p>

- (ii) substantial shareholders of the Managers; and
 - (iii) associates of the directors or substantial shareholders of the Managers; and
- (c) in relation to an issuer which is a collective investment scheme, means all persons or members of the public but excludes -
- (i) directors and substantial shareholders of the management company;
 - (ii) substantial unit holders of a collective investment scheme except where such a unit holder fulfils all the requirements set out in subparagraph (a)(ii) above as if the unit holder is the shareholder referred in subparagraph (a)(ii), in which case such unit holder may be included as a "public" unit holder;
 - (iii) trustee of a collective investment scheme; and
 - (iv) associates of the directors of the management company or substantial unit holders of a collective investment scheme.
- (d) in relation to the voting securities of a SPAC, means all persons or members of the public but excludes –
- (i) directors of the SPAC;
 - (ii) substantial voting securities holders of a SPAC except where such a voting securities holder fulfils all the requirements set out in subparagraph (a)(ii) above as if the voting securities holder is the shareholder referred in sub-paragraph (a)(ii), in which case such voting securities holder may be included as a "public" voting securities holder; and
 - (iii) associates of directors or substantial voting securities holders of the SPAC.

For the avoidance of doubt, a "public" shareholder also excludes a person who holds or acquires shares through artificial means. This includes, for example, giving away free shares or shares as gifts or providing financial assistance or loans to acquire shares to nominees of the directors or substantial shareholders.

qualifying acquisition in relation to a SPAC, means the initial acquisition of business(es) by a SPAC which has an aggregate fair market value equal to at least 80% of the aggregate amount in a Trust Account and is in line with the business strategy disclosed in the listing prospectus issued in relation to the SPAC's initial public offering.

real estate means land and all things that are a natural part of the land as well as things attached to the land both below and above the ground, and includes the rights, interests and benefits related to the ownership of the real estate.

real estate investment trust	means a collective investment scheme that invests or proposes to invest primarily in income-generating real estate.
Recognised Stock Exchange	means – <ul style="list-style-type: none"> (a) a body corporate which has been approved by the Minister under section 8(2) of the CMSA; or (b) a foreign stock exchange declared by the Exchange to be a recognised stock exchange.
Record of Depositors	means a record provided by the Depository to a listed issuer under chapter 24.0 of the Rules of the Depository.
register	means the register of members to be kept pursuant to the Companies Act 1965.
related corporation	means a corporation which is – <ul style="list-style-type: none"> (a) the holding company of another corporation; (b) a subsidiary of another corporation; or (c) a subsidiary of the holding company of another corporation.
related party	means a director, major shareholder or person connected with such director or major shareholder. For the purpose of this definition, “ director ” and “ major shareholder ” have the meanings given in paragraph 10.02 of these Requirements.
RM and sen	means Ringgit Malaysia and sen respectively.
Rules of the Depository	means the Rules of Bursa Malaysia Depository Sdn Bhd, including any amendment that may be made from time to time.
Rules of the Exchange	means the Rules of Bursa Malaysia Securities Berhad, including any amendment that may be made from time to time.
SC	means the Securities Commission established under section 3 of the Securities Commission Act 1993.
SC’s Equity Guidelines	includes any Practice Notes and any other documents issued by the SC in relation to the Guidelines.
secondary listing	means admission to the Official List other than by way of primary listing.
securities	has the meaning given in section 2(1) of the CMSA.
securities account	means an account established by the Depository for a depositor for the recording of deposit of securities and for dealing in such securities by the depositor.
share scheme for employees	means a share scheme involving a new issue of shares to employees.
significant change in	has the meaning given in the SC’s Equity Guidelines.

the business direction or policy	
singly quoted shares	means shares, which have a limit, quota or restriction on the ownership by a foreigner imposed by the memorandum and articles of association or any other constituent document of a listed corporation but which shares are not separately quoted on the Exchange.
special purpose acquisition company or SPAC	means a corporation which has no operations or income generating business at the point of initial public offering and has yet to complete a qualifying acquisition with the proceeds of such offering.
stabilizing action	means such action as may be taken by the stabilizing manager under the Capital Markets and Services (Price Stabilization Mechanism) Regulations 2008 for the sole purpose of preventing or minimizing any reduction in the market price of equity securities listed on the Official List.
stabilizing manager	means a person appointed under the Capital Markets and Services (Price Stabilization Mechanism) Regulations 2008 to undertake a stabilizing action on behalf of the listed corporation.
substantial shareholder	has the meaning given in section 69D of the Companies Act 1965.
substantial unit holder	means a person who holds 5% or more of the total number of units in a collective investment scheme.
Take-Overs and Mergers Code	means the Malaysian Code on Take-Overs and Mergers 1998, including any amendment that may be made from time to time.
these Requirements	means Bursa Malaysia Securities Berhad Main Market Listing Requirements, including any amendment that may be made from time to time.
treasury shares	has the meaning given in section 67A(3A) of the Companies Act 1965.
Trust Account	in relation to a SPAC, means a trust account maintained with a licensed bank or merchant bank as defined in the Banking and Financial Institutions Act 1989, by a custodian appointed by the SPAC to hold on its behalf, proceeds from an issuance of securities by the SPAC.
unit holder	means the unit holder of a collective investment scheme.
voting securities	in relation to a SPAC, means the securities issued by a SPAC which confer upon the holders, voting rights.

PART B – INTERPRETATION

1.02 Interpretation

- (1) Unless otherwise defined in these Requirements or unless the context otherwise requires, words or expressions defined in the Companies Act 1965, when used in these Requirements, have the same meanings as in the Companies Act 1965.

-
- (2) Apart from the above, certain other terms and expressions have also been defined in the respective Chapters. Such definitions only apply with respect to the respective Chapters in which they are contained.
 - (3) The terms and expressions defined in paragraph 1.01 are also applicable to any Practice Note, unless otherwise defined in the Practice Note.
 - (4) Where an act is required to be done a specified number of “clear market days” before or after a specified date, at least that number of market days must intervene between the day on which the act is done and that date.
 - (5) Unless the context requires otherwise, where the securities are listed and quoted in foreign currency, references to Ringgit in regard to the listed securities will be modified to mean its equivalent in foreign currency.

1.03 Incidental powers etc of the Exchange

Where any provision of these Requirements empowers, authorises or enables the Exchange to do or enforce the doing of any act or thing, the Exchange has all such powers or rights as may be necessary or reasonably incidental to the Exchange doing or enforcing the doing of the act or thing.

1.04 Gender

Unless the context otherwise requires, words importing gender include all genders.

1.05 Singular and plural

Unless the context otherwise requires, words importing the singular number include the plural number and vice versa.

1.06 Headings

The headings and sub-headings in these Requirements are inserted for convenience of reference only.

1.07 Appendices

- (1) The Appendices are to be taken, read and construed as an essential part of these Requirements.
- (2) Appendices which take the form of forms will not be printed and furnished by the Exchange. Applicants and listed issuers are required to produce their own forms which strictly adhere to the relevant Appendices.

1.08 Schedules

The Schedules are to be taken, read and construed as an essential part of these Requirements.

1.09 References

- (1) References to paragraphs, Parts and Chapters unless otherwise stated are to be construed as references to paragraphs, Parts and Chapters of these Requirements.
- (2) References to Appendices and Schedules unless otherwise stated are to be construed as references to Appendices and Schedules of these Requirements.
- (3) References to the provisions of statutes and subordinate legislation include such provisions as amended or re-enacted from time to time.

- (4) References to statutes and subordinate legislation include any consolidation, replacement or revision of the same.

[End of Chapter]

CHAPTER 2 GENERAL**PART A – GENERAL****2.01 Introduction**

This Chapter sets out -

- (a) the principles upon which these Requirements are based and applied; and
- (b) the general requirements of the Exchange which apply to all applicants, listed issuers, management companies, trustees, their directors, officers, advisers and other persons to whom these Requirements are directed.

2.02 Purpose of these Requirements

The purpose of these Requirements is to set out the requirements that must be complied with by all applicants, listed issuers, management companies, trustees, their directors, officers, advisers or other persons to whom these Requirements are directed. Failure to comply with any of these Requirements will amount to a breach in respect of which actions may be taken or penalties may be imposed or both.

2.03 General principles

The principles on which these Requirements are based, include the following:

- (1) all applicants will be of a certain quality and have a record of operations of adequate duration;
- (2) investors and the public will be kept fully informed by the listed issuers of all facts or information that might affect their interests and in particular, full, accurate and timely disclosure will be made of any information which may reasonably be expected to have a material effect on the price, value or market activity in the securities of listed issuers;
- (3) all holders of securities will be treated fairly and equitably;
- (4) directors, officers and advisers of listed issuers will maintain the highest standards of integrity, accountability, corporate governance and responsibility; and
- (5) directors of listed issuers will act in the interests of the corporation as a whole, particularly where the public represents only a minority of the shareholders or where directors or major shareholders have material interests in transactions entered into by listed issuers.

PART B - APPLICATION OF THESE REQUIREMENTS**2.04 Obligation to comply**

- (1) A listed issuer, whether or not admission of its securities has taken place before these Requirements are prescribed, is, by virtue of its admission to the Official List, bound by these Requirements and the Rules of the Exchange.
- (2) A listed issuer, a management company, a trustee, its directors, officers, advisers or any other person to whom these Requirements are directed must comply with these Requirements for so long as the listed issuer or its securities remain listed on the Official List. This applies even during periods when the listed issuer's securities are suspended from trading.

2.05 Spirit of these Requirements

These Requirements will be interpreted -

- (a) in accordance with their spirit, intention and purpose; and
- (b) in a way that best promotes the principles on which they are based.

2.06 Waivers and modifications

- (1) The Exchange requires strict compliance with these Requirements.
- (2) Notwithstanding subparagraph (1) above, the Exchange may at any time, waive or modify compliance with a Requirement or any part of a Requirement. If the Exchange waives or modifies compliance with a Requirement or part of a Requirement subject to a condition, the condition must be complied with for the waiver or modification of compliance to be effective.

2.07 Varying or revoking decisions

The Exchange may, at any time, vary or revoke its decision where the circumstances warrant it, subject to any condition it deems fit. An unconditional variation or revocation has effect from the date specified by the Exchange. If a variation or revocation is subject to a condition, the condition must be complied with for the variation or revocation to be effective.

2.08 Practice Notes

- (1) The Exchange may, from time to time, issue Practice Notes subject to the approval of the SC to provide, amongst others -
 - (a) interpretation of these Requirements; or
 - (b) administrative or operational procedures in relation to these Requirements.
- (2) The Exchange may amend, waive or repeal such Practice Notes from time to time.
- (3) A listed issuer, a management company, a trustee, its directors, officers, advisers or any other person to whom these Requirements are directed must comply with the Practice Notes issued pursuant to this paragraph in the same manner as these Requirements. For the avoidance of doubt, unless the context otherwise requires, directions and requirements contained in the Practice Notes are in clarification of and not in derogation of any obligations of persons to whom these Requirements or the Practice Notes apply.
- (4) Unless otherwise defined in the Practice Notes or the context otherwise requires, words or expressions defined in these Requirements, when used in the Practice Notes, have the same meaning as in these Requirements.

2.09 Application of these Requirements to the management company of a collective investment scheme

If a Requirement imposes an obligation on an applicant or a listed issuer which is a collective investment scheme, the management company of such collective investment scheme must make ensure that the collective investment scheme complies with the said Requirement.

PART C - DOCUMENTS TO COMPLY WITH THESE REQUIREMENTS**2.10 Documents to comply with these Requirements**

- (1) An applicant or a listed issuer must ensure that -
 - (a) any articles of association, trust deed, deed poll or bylaws of a share scheme for employees which is required to be submitted to the Exchange ("**said documents**"); or
 - (b) any amendment to the said documents,complies with these Requirements.
- (2) A listed issuer must ensure that no amendment is made to the said documents unless the amendment is made -
 - (a) with the prior approval of its securities holders, except where it is otherwise provided in the said document; and
 - (b) the approvals of the relevant authorities are obtained (where applicable).

2.11 Timing of submission

An applicant or a listed issuer must ensure that the said documents or any amendment to the said documents, are submitted to the Exchange not later than 5 market days after the effective date of the relevant documents or any amendment to them, as the case may be.

2.12 Letters of compliance

- (1) A listed issuer must submit a letter of compliance together with the said documents and any amendment to the said documents.
- (2) A letter of compliance is a letter written to the Exchange which confirms that the provisions of the said documents to which it relates comply with these Requirements and the Rules of the Depository.
- (3) Where the letter of compliance is in relation to an amendment of any of the said documents, it must confirm that the amended document complies with these Requirements and the Rules of the Depository.
- (4) A letter of compliance must be written by a person with legal qualifications, provided that in the circumstances set out below, the letter of compliance may be written by the following additional persons:
 - (a) in the case of bylaws of a share scheme for employees (and any amendment thereto), by the listed issuer's advisers; and
 - (b) in the case of an amendment to an articles of association, by the listed issuer's advisers or its company secretary.

[Cross reference: Practice Notes 21; ~~Practice Note~~ and 24]

PART D - INFORMATION**2.13 Form of information**

- (1) If any of these Requirements stipulates that a person is to provide information to the Exchange, that information must be provided in writing unless otherwise specified by the Exchange.
- (2) The Exchange may require any information or document that is to be provided to the Exchange by an applicant, a listed issuer or its advisers to be through an electronic medium as directed by the Exchange and in a manner determined by the Exchange.
- (3) An applicant, a listed issuer, or its advisers must pay to the Exchange fees of such amount as may be determined by the Exchange from time to time in relation to the said electronic medium.

2.14 Giving the Exchange information

An applicant, a listed issuer, a management company, a trustee, its directors, officers, employees, advisers or any other person to whom these Requirements are directed must give the Exchange any information, document or explanation that the Exchange requests for in accordance with the instructions or request of the Exchange.

2.15 Submission of information

Where any document is submitted to the Exchange for public release, an applicant, a listed issuer or its advisers must clearly mark the document with the words "For Immediate Release".

2.16 Documents forwarded to the Exchange

All documents forwarded to the Exchange will become and remain the property of the Exchange which may, in its absolute discretion, deal with them as it wishes including copying, storing in a retrieval system, transmitting to the public, publishing or disclosing all or any part of the documents and forwarding copies to any stock exchange, relevant government bodies or authorities or any expert or consultant acting in a professional capacity for and on behalf of the Exchange.

2.17 Verification of report or information

The Exchange may, at its discretion, instruct or direct an applicant or a listed issuer to appoint an independent adviser or expert at the expense of such applicant or listed issuer to verify any report or information referred to in or which forms part of any application, submitted to the Exchange by or on behalf of such applicant or listed issuer and to submit the results of such verification to the Exchange directly.

2.18 Contents of statement, information or document

- (1) An applicant, a listed issuer or an adviser or a director of an applicant or a listed issuer must ensure that any application, proposal, statement, information or document presented, submitted or disclosed pursuant to these Requirements -
 - (a) is clear, unambiguous and accurate;
 - (b) does not contain any material omission; and
 - (c) is not false or misleading.

-
- (2) An applicant, a listed issuer or an adviser or a director of an applicant or a listed issuer does not commit a breach of subparagraph (1) above if such person proves that -
- (a) he had made all enquiries as were reasonable in the circumstances; and
 - (b) after making such enquiries, he had reasonable grounds to believe and did believe until the time of the presentation, submission or disclosure of the statement, information or document to the Exchange that the statement, information or document did fulfil the requirements of subparagraph (1).
- (3) Where any statement, information or document referred to in subparagraph (1) above has been presented, submitted or disclosed to the Exchange and the person referred to in subparagraph (1) above subsequently becomes aware that the statement, information or document may not fulfil the requirements of subparagraph (1) above, the person must immediately notify the Exchange of the same.
- (4) For the avoidance of doubt, in the case of an announcement to the Exchange or a circular, paragraphs 9.16 or 9.32 apply respectively, in substitution of subparagraphs (1) to (3) above.

2.19 Indemnity

- (1) Where the Exchange publishes, releases or disseminates any statement, information or document for or on behalf of an applicant or listed issuer pursuant to these Requirements or otherwise, the Exchange will not be responsible to check the accuracy, completeness or adequacy of any of the contents of such statement, information or document, and will not be liable for any loss or damage howsoever arising as a result of publishing, releasing or disseminating the statement, information or document.
- (2) An applicant, a listed issuer or an adviser or director of an applicant or listed issuer must fully indemnify and hold indemnified the Exchange against any loss, damage, liability, cost or expense (including legal costs) suffered or incurred by the Exchange, whether directly or indirectly, as a result of any demand, action or proceeding by any person for, on account of, or in respect of the publication, release or dissemination by the Exchange of any such statement, information or document for or on behalf of an applicant or listed issuer.

PART E – LISTING FEES AND OTHER CHARGES

2.20 Fees

An applicant or a listed issuer, must pay to the Exchange such fees and charges set out in the Schedule of Fees which are applicable to them, in the amount and manner specified in the Schedule of Fees.

PART F - ADVISERS

2.21 Undertaking by adviser

- (1) An adviser who presents, submits or discloses an application, a circular or any other document to the Exchange on behalf of an applicant or a listed issuer must have lodged with the Exchange an undertaking duly executed by the adviser in the form of Appendix 2A.
- (2) The Exchange reserves the right to reject or not accept any application, circular or any other document submitted by an adviser on behalf of an applicant or a listed issuer where such adviser has not lodged with the Exchange an undertaking referred to in subparagraph (1) above.

-
- (3) The acceptance by the Exchange of the undertaking referred to in subparagraph (1) above is not an indication of approval or endorsement by the Exchange as to the skill, competency, fitness or capability of such person as an adviser.

PART G – OTHER PERSON PRIMARILY RESPONSIBLE FOR LISTED ISSUER

2.22 Undertaking by a person responsible for a listed issuer

- (1) Where a person, pursuant to a Court order or otherwise, is appointed to take possession or control over all or major assets of, or becomes responsible for the management of a listed issuer ("**Controlling Person**"), the listed issuer must ensure and the Controlling Person must give, the Exchange an undertaking in the form of Appendix 2B to comply with these Requirements.
- (2) A Controlling Person must –
- (a) provide the Exchange any information, document or explanation that the Exchange requests for in accordance with the instructions or request of the Exchange; and
 - (b) comply with any instruction, directive or condition issued by the Exchange and within such time as may be specified by the Exchange.
- (3) A Controlling Person must not -
- (a) cause, aid or abet a breach of these Requirements by a listed issuer referred to in subparagraph (1) above; or
 - (b) permit, either knowingly or where he had reasonable means of obtaining such knowledge, such listed issuer to commit a breach of these Requirements.

PART H – OTHERS

2.23 Instructions or directives issued by the Exchange

- (1) The Exchange may, from time to time, issue any instruction or directive to or impose any condition on an applicant, a listed issuer, a management company, a trustee, its directors, officers, employees, advisers or any other person to whom these Requirements are directed and such person as aforesaid must comply with the said instruction, directive or condition and within such time as may be specified by the Exchange.
- (2) Where the Exchange has issued any instruction or directive or imposed any condition referred to in subparagraph (1) above, the Exchange has all the rights and powers to do all acts necessary to enforce and give effect to the instruction, directive or condition.

2.24 Special auditor

- (1) Where the Exchange is of the opinion that a breach of these Requirements may have occurred and the appointment of a special auditor is necessary, the Exchange may instruct the listed issuer to appoint a special auditor to review or investigate the affairs of the listed issuer, any of its subsidiaries or both, as the Exchange may direct. Any cost incurred as a result of the appointment of the special auditor must be borne by the listed issuer.
- (2) For the purpose of this paragraph, a special auditor means any auditor other than the statutory auditor of the listed issuer appointed pursuant to the Companies Act 1965 or in relation to a foreign corporation, pursuant to the relevant laws of the place of incorporation.

2.25 Conduct

Any act or omission by a person includes an act or omission caused directly or indirectly by the said person.

2.26 Notices by the Exchange

- (1) All notices or written communications required to be sent by the Exchange to a listed issuer or an adviser under these Requirements will be sent to the registered office or the last known address of the listed issuer or adviser, as the case may be, as contained in the records of the Exchange.
- (2) All notices or written communications required to be sent by the Exchange to a director under these Requirements will be sent to the last known place of residence of the director or the last known address of the director, as contained in the records of the Exchange.
- (3) Where any notice or written communication is required to be sent by the Exchange under these Requirements, such notice or written communication will be deemed received in the following circumstances:
 - (a) if sent by post, on the 3rd day after posting;
 - (b) if sent by courier, on the 2nd day after despatch; and
 - (c) if sent by facsimile transmission, immediately.
- (4) Notwithstanding subparagraph (1) above, the Exchange may specify other methods of communication including electronic mail, other electronic medium or advertisement in newspapers in which event such notice or written communication will be deemed received immediately.

2.27 Issuance of new securities in foreign currency

- (1) An issue of securities by a listed issuer will be quoted in Ringgit or such other foreign currency as may be allowed by the Exchange.
- (2) A listed issuer must consult the Exchange and obtain the approval of the Controller of Foreign Exchange if it prefers the securities to be quoted in foreign currency.

PART I - AMENDMENTS TO THESE REQUIREMENTS**2.28 Amendments to these Requirements**

The Exchange has the right to amend all or any of these Requirements from time to time, pursuant to section 9 of the CMSA and any such amendment will be binding on an applicant, a listed issuer, a management company, a trustee, its directors, officers, advisers or any other person to whom these Requirements are directed.

PART J – EXCHANGE HOLDING COMPANY AND THE EXCHANGE**2.29 Powers of the Exchange Holding Company**

- (1) Where any provision of these Requirements confers a right or power on the Exchange to do any act or thing such provision will be deemed to confer the right or power on the Exchange Holding Company to do such act or thing on behalf of the Exchange.

-
- (2) An applicant, a listed issuer, a management company, a trustee, its directors, officers, advisers and other persons to whom these Requirements are directed must comply with, observe or give effect to any action of the Exchange Holding Company pursuant to subparagraph (1) above.

2.30 Liability of the Exchange etc

Without prejudice to any immunity or defense available to the following persons by statute or in law, none of such persons will be liable in respect of anything done or omitted to be done by such persons in good faith in connection with the discharge or performance or purported discharge or performance of any function or duty, or the exercise or intended exercise of any power under these Requirements or any applicable law or in respect of any decision made or enforcement action taken or notice of publication thereof, whether resulting in any loss of profit, costs, damages or damage to reputation or otherwise:

- (a) the Exchange or the Exchange Holding Company;
- (b) any member of the Board of the Exchange or Exchange Holding Company or any member of any committee of the Exchange or Exchange Holding Company;
- (c) any officer of the Exchange or Exchange Holding Company; or
- (d) any agent of, or any person acting under the direction of the Exchange or Exchange Holding Company.

[End of Chapter]

APPENDIX 2A

Undertaking by an adviser
(paragraph 2.21(1))

To

Bursa Malaysia Securities Berhad
Exchange Square
Bukit Kewangan
50200 Kuala Lumpur

Compliance with Main Market Listing Requirements

In consideration of Bursa Malaysia Securities Berhad (“**Bursa Securities**”) allowing us to act as advisers for applicants seeking listing on the Official List of Bursa Securities or listed issuers, WE[name of the adviser] having a #registered address/place of business at..... UNDERTAKE AND AGREE to comply with Bursa Securities Main Market Listing Requirements (“**Listing Requirements**”), including any amendment as may be made from time to time, insofar as the same apply to us as advisers.

The terms “adviser”, “applicant”, “listed issuer” and “Official List” have the meanings given under the Listing Requirements.

**This Undertaking is deemed to have been made in Malaysia and the construction, validity and performance of this Undertaking are governed in all respects by the laws of Malaysia and WE/I irrevocably submit to the jurisdiction of the Malaysian Courts.

The above Undertaking has been signed by us/me as..... [title/designation] of[name of adviser] pursuant to authority granted to us/me by resolution of the board of directors of the adviser on.....

Date:

Signature:

Name:

Delete as appropriate

** Applicable to a foreign adviser only.

[End of Appendix]

Appendix 2B
Undertaking by a person responsible
for the management of a listed issuer

APPENDIX 2B

Undertaking by a person responsible for the management of a listed issuer
(paragraph 2.22)

To

Bursa Malaysia Securities Berhad
Exchange Square
Bukit Kewangan
50200 Kuala Lumpur

Compliance with Main Market Listing Requirements

#I/We,[name and NRIC/Company No.], am a
.....[position/designation] of[name(s) of listed issuer(s)]
("Company(ies)") which # has/have been admitted to and # is/are currently listed on the
Official List of Bursa Malaysia Securities Berhad ("Official List").

In consideration of the Exchange allowing the continued listing of the Company(ies) on the
Official List, #I/We, UNDERTAKE AND AGREE to comply with Bursa Malaysia Securities
Berhad Main Market Listing Requirements, including any amendment as may be made from
time to time, in so far as the same apply to #me/us.

**This Undertaking is deemed to have been made in Malaysia and the construction, validity
and performance of this Undertaking are governed in all respects by the laws of Malaysia and
I irrevocably submit to the jurisdiction of the Malaysian Courts.

Yours faithfully,

.....

Name:

Designation:

Date:

Delete as appropriate

** Applicable to a foreign person who is responsible for the management of a listed issuer
only.

[End of Appendix]

CHAPTER 3 ADMISSION**PART A – GENERAL****3.01 Introduction**

- (1) This Chapter sets out the requirements that must be complied with by an applicant seeking admission to the Official List.
- (2) Additional or exceptional requirements relating to admission to the Official List are also set out in the following Chapters:
 - (a) Chapter 4 for applicants which are closed-end funds, management companies of real estate investment trusts or exchange-traded funds as well as real estate investment trusts and exchange-traded funds, and the special purpose acquisition companies; and
 - (b) Chapter 4A for applicants which are foreign corporations and companies-corporations seeking a secondary listing on the Exchange.
- (3) Where a listed corporation undertakes a corporate proposal which will result in a significant change in the business direction or policy of a listed corporation, the Exchange will treat such listed corporation as if it were a new applicant seeking admission to the Official List. In such instance, the listed corporation must comply with the requirements under this Chapter, where applicable.
- (4) For the purposes of this Chapter, unless the context otherwise requires, references to “applicant” includes a listed corporation that undertakes a corporate proposal which will result in a significant change in the business direction or policy of a listed corporation.

PART B - ADMISSION**3.02 Admission**

- (1) The Exchange will exercise discretion over the admission and continued listing of securities on its Official List and may approve or reject applications for listing, as it deems fit.
- (2) The Exchange may also approve applications for listing unconditionally or subject to such conditions, as it deems fit.
- (3) An applicant must submit its listing application through a ~~an~~ Principal Adviser.
- (4) An applicant must comply with the relevant admission procedures and requirements as may be prescribed by the Exchange.

[Cross-reference: Practice Note 21]

3.03 Approval from other authorities

An applicant must first obtain approval(s) from the SC and other relevant authorities (where applicable) before listing and quotation of any security will be considered by the Exchange.

CHAPTER 4 ADMISSION FOR SPECIFIC APPLICANTS**PART A - GENERAL****4.01 Introduction**

- (1) This Chapter sets out the special requirements, which may be in addition or, as an exception to those set out in Chapter 3, that must be complied with by an applicant which is -
- (a) a closed-end fund (Part B);
 - (b) a management company of a real estate investment trust as well as a real estate investment trust (Part C);
 - (c) a management company of an exchange traded fund as well as an exchange traded fund (Part D), or
 - (d) a special purpose acquisition company (Part E),
- seeking a listing of its securities or units of a real estate investment trust or an exchange traded fund, as the case may be, on the Official List.
- (2) Where any requirement in this Chapter conflicts with a requirement of another Chapter, the former will prevail.

PART B - CLOSED-END FUNDS**4.02 Requirement in respect of independent director**

For the purpose of complying with paragraph 3.04 with regard to the requirement of having “independent directors”, a director who is related in any way to any of the major shareholders of the Managers must not be considered as such.

4.03 Shareholding spread of closed-end funds

A closed-end fund must comply with the requirements of paragraph 3.06.

PART C – REAL ESTATE INVESTMENT TRUSTS**4.04 Admission**

The management company and trustee of a real estate investment trust must comply with the relevant admission procedures and requirements as may be prescribed by the Exchange.

[Cross reference: Practice Notes 21 and 23]

4.05 Independent director of management company

The management company must ensure that the composition of its board of directors complies with the requirements of paragraph 3.04 as if it were the applicant mentioned in paragraph 3.04. For the purpose of this paragraph, “independent director” has the meaning given to “**independent member**” in the SC’s Guidelines on Real Estate Investment Trusts.

4.06 Requirement for audit committee not applicable

The provisions in these Requirements in relation to audit committees are not applicable to a real estate investment trust.

4.07 Unit spread of real estate investment trust

The management company seeking a listing on the Main Market of units of a real estate investment trust must ensure that the real estate investment trust complies with the requirements of paragraph 3.06 as if the real estate investment trust is the applicant, the units are the shares and the public unit holders are the public shareholders mentioned in paragraph 3.06.

4.08 Provisions in the trust deed

- (1) The management company must ensure that the trust deed governing the issue of the real estate investment trust units includes the various provisions set out in Appendix 4A.
- (2) The management company must furnish to the Exchange a letter of compliance pursuant to paragraph 2.12 together with the trust deed and a checklist showing compliance with Appendix 4A.

PART D – EXCHANGE TRADED FUNDS**4.09 Admission**

The management company and trustee of an exchange traded fund must comply with the relevant admission procedures and requirements as may be prescribed by the Exchange.

[Cross reference: Practice Notes 21 and 23]

4.10 Independent directors of management company

The management company of an exchange traded fund must ensure that the composition of its board of directors complies with the requirements of paragraph 3.04 as if it were the applicant mentioned in paragraph 3.04. For the purpose of this paragraph, “independent director” has the meaning given to “**independent member**” in the SC’s ~~Guidelines on Exchange Traded Funds~~[Exchange-Traded Funds Guidelines](#).

4.11 Requirement for audit committee not applicable

The provisions in these Requirements in relation to audit committees are not applicable to an exchange traded fund.

4.12 Unit spread of exchange traded fund

The Exchange may require the management company to comply with such unit spread requirements as may be prescribed by the Exchange in relation to an exchange traded fund.

4.13 Provisions in the deed

- (1) The management company must ensure that the deed governing the issue of the exchange traded fund units includes the various provisions set out in Appendix 4B.
- (2) The management company must furnish to the Exchange a letter of compliance pursuant to paragraph 2.12 together with the deed and a checklist showing compliance with Appendix 4B.

PART E – SPECIAL PURPOSE ACQUISITION COMPANIES**4.14 Admission**

A SPAC must comply with the relevant admission procedures and requirements as may be prescribed by the Exchange.

[Cross reference: Practice Notes 21 and 23]

4.15 Shareholding spread of a SPAC

A SPAC seeking a listing on the Main Market must comply with the requirements of paragraph 3.06 as if the SPAC is the applicant, the voting securities are the shares, and the public securities holders are the public shareholders mentioned in paragraph 3.06.

[End of Chapter]

Appendix 4A
Contents of deed for a real estate investment trust

APPENDIX 4A**Contents of deed in respect of a real estate investment trust**
(paragraph 4.08(1))

- (1) At least 14 days' notice in writing of any meeting (other than a meeting convened to pass a special resolution) of unit holders shall be given by the trustee. In the case of a meeting convened to pass a special resolution, at least 21 days' notice shall be given. Such notice will specify in a circular the general nature of the business to be transacted.
- (2) The trustee shall cause at least 14 days' notice (21 days in the case of special resolution to be passed) to be given of any meeting by advertisement in a national language daily newspaper and in one other newspaper as may be approved by the SC, and in writing to the Exchange.
- (3) A unit holder shall be entitled to attend and vote at any meeting of unit holders, and shall be entitled to appoint another person (whether a unit holder or not) as his proxy to attend and vote. Where the unit holder is an authorised nominee as defined under the Securities Industry (Central Depositories) Act 1991, it may appoint at least 1 proxy in respect of each securities account it holds with units standing to the credit of the said securities account. Where a unit holder appoints 2 proxies in accordance with this provision the appointment shall be invalid unless he specifies the proportions of his holdings to be represented by each proxy. Such proxy shall have the same rights as the member to vote whether on a poll or a show of hands, to speak and to be reckoned in a quorum.
- (4) In the case of an equality of votes the chairman of a meeting of unit holders shall have a casting vote in addition to his votes (if any) as a unit holder both on a show of hands and on a poll.

[End of Appendix]

Appendix 4B
Contents of deed in respect of an exchange traded fund

APPENDIX 4B**Contents of deed in respect of an exchange traded fund**

(paragraph 4.13)

- (1) At least 14 days' notice in writing of any meeting (other than a meeting convened to pass a special resolution) of unit holders shall be given by the trustee. In the case of a meeting convened to pass a special resolution, at least 21 days' notice shall be given. Such notice will specify in a circular the general nature of the business to be transacted.
- (2) The trustee shall cause at least 14 days' notice (21 days in the case of a special resolution to be passed) to be given of any meeting by advertisement in a national language daily newspaper and in one other newspaper as may be approved by the SC, and in writing to the Exchange.
- ~~(3) (a) The quorum for a meeting of unit holders for a meeting at which an ordinary resolution only is to be proposed shall be at least 5 persons~~
- ~~(b) The quorum for a meeting of unit holders for a meeting at which a special resolution is to be proposed shall be at least 5 persons holding or representing by proxy at least 25 per cent of the number of units in issue at the time of meeting.~~
- ~~(4)~~(3) A unit holder shall be entitled to attend and vote at any meeting of unit holders, and shall be entitled to appoint another person (whether a unit holder or not) as his proxy to attend and vote. Where the unit holder is an authorised nominee as defined under the Securities Industry (Central Depositories) Act 1991, it may appoint at least 1 proxy in respect of each securities account it holds with units standing to the credit of the said securities account. Where a unit holder appoints 2 proxies in accordance with this provision the appointment shall be invalid unless he specifies the proportions of his holdings to be represented by each proxy. Such proxy shall have the same rights as the member to vote whether on a poll or a show of hands, to speak and to be reckoned in a quorum.
- ~~(5)~~(4) In the case of an equality of votes the chairman of a meeting of unit holders shall have a casting vote in addition to his votes (if any) as a unit holder both on a show of hands and on a poll.
- ~~(6) — Every question arising at a general meeting of unit holders shall be decided in the first instance by a show of hands, provided that a poll shall be taken in any case where —~~
 - ~~(a) — it is required by the deed or by law that the question be decided by a majority which is to be measured by a percentage of the votes of those present; or~~
 - ~~(b) — it is demanded either before or immediately after any question is put to a show of hands by the chairman, the trustee, the management company, or unit holders present, holding (or representing by proxy) between them not less than one-tenth of the total number of units in issue.~~
- ~~(7) — Upon any question decided by a show of hands each unit holder present and each proxy shall have one vote and upon any question decided by a poll each unit holder present in person or by proxy shall have one vote for each fully paid unit.~~

[End of Appendix]

CHAPTER 4A FOREIGN LISTING**PART A - GENERAL****4A.01 Introduction**

This Chapter sets out the requirements that must be complied with by a foreign corporation seeking or having a primary listing, and a corporation seeking or having a secondary listing, on the Main Market.

PART B – ADMISSION REQUIREMENTS FOR A PRIMARY LISTING**4A.02 Introduction**

- (1) Unless the context requires otherwise, an “**applicant**” in this Part B means a foreign corporation seeking a primary listing on the Main Market.
- (2) An applicant must comply with Chapters 3 and 4 of these Requirements, as the case may be, subject to the additional requirements, modifications or exceptions set out in this Chapter.
- (3) Where any requirement in this Chapter conflicts with a requirement of another Chapter, the former prevails.

4A.03 Share transfer or registration office

An applicant must establish a share transfer or share registration office in Malaysia.

4A.04 Appointment of directors

An applicant -

- (a) whose operations are entirely or predominantly Malaysian-based must have a majority of directors whose principal or only place of residence is within Malaysia; and
- (b) whose operations are entirely or predominantly foreign-based must have at least 1 director whose principal or only place of residence is within Malaysia.

4A.05 Agent or representative

An applicant must appoint an agent or representative in Malaysia to be responsible for communication with the Exchange, on behalf of the applicant.

4A.06 Admission

An applicant must comply with the relevant admission procedures and requirements as may be prescribed by the Exchange.

[Cross reference: Practice Notes 21 and ; ~~Practice Note-24~~]

PART C – SPECIFIC CONTINUING OBLIGATIONS RELATING TO FOREIGN CORPORATIONS WITH A PRIMARY LISTING**4A.07 Introduction**

- (1) A foreign corporation with a primary listing on the Main Market must comply with all the other Chapters in these Requirements subject to the additional requirements, modifications or exceptions set out in this Chapter.
- (2) Where any requirement in this Chapter conflicts with a requirement of another Chapter, the former prevails.

4A.08 ~~Directors~~Other obligations

A foreign corporation with a primary listing must comply with paragraphs [4A.03](#), [4A.04](#) and [4A.05](#) as a continuing listing obligations.

4A.09 Auditing standards

A foreign corporation with a primary listing must ensure that the auditing standards applied are in accordance with [the](#) approved auditing standards applied in Malaysia or International Standards on Auditing.

4A.10 Information/documents in English

All information or documents presented, submitted or disclosed pursuant to these Requirements must be in English.

4A.11 Information to be disclosed

A foreign corporation with a primary listing must announce to the Exchange concurrently all information required to be publicly disclosed to its domestic regulatory authorities and other stock exchanges, if applicable.

4A.12 Distribution of notices etc

A foreign corporation with a primary listing must distribute to its shareholders in Malaysia all -

- (a) notices of general meetings to be held;
- (b) annual reports;
- (c) accounts; and
- (d) ~~all~~ other documents or information,

which it is required to distribute in its place of incorporation and other stock exchanges, if applicable. The foreign corporation must give sufficient notice to enable its shareholders in Malaysia to comply with the terms of the notice.

4A.13 Announcement of appointment of directors

Without prejudice to paragraph 9.19 on the making of immediate announcements to the Exchange, the announcements made by a foreign corporation with a primary listing with regard to the appointment of a director must include the director's principal place of residence.

4A.14 Substantial shareholdings

- (1) A foreign corporation with a primary listing must immediately announce to the Exchange any change in the interest or interests of a substantial shareholder in its voting shares upon notification by the substantial shareholder.
- (2) The foreign corporation must state the name of the shareholder and full particulars of the change, including the date of the change, the number of shares involved and the circumstances by reason of which the change occurred.

4A.15 Financial statements

A foreign corporation with a primary listing must ensure that any financial statements announced to the Exchange are -

- (a) prepared on a consolidated basis; and
- (b) prepared in accordance with the approved accounting standards as defined in the Financial Reporting Act, 1997.

4A.16 Statutory declaration in relation to annual audited financial statements

- (1) The annual audited financial statements of a foreign corporation with a primary listing must be accompanied by a statutory declaration which is signed by the director or person primarily responsible for the financial management of the corporation, as the case may be, who satisfies the requirements prescribed in paragraph 9.27.
- (2) The signatory referred to in subparagraph (1) above must set forth his opinion as to the correctness or otherwise of the annual audited financial statements.

4A.17 Notification of suspension and de-listing

- (1) A foreign corporation with a primary listing must immediately notify the Exchange in writing where it has requested for a suspension in trading or a de-listing of its securities listed on other stock exchange(s).
- (2) If the other stock exchange(s) decide(s) to suspend trading in or de-list the securities of a foreign corporation with a primary listing, whether in relation to its request under subparagraph (1) above or otherwise, the corporation must immediately notify the Exchange in writing.

4A.18 ~~Listing-Admission~~ and quotation of new issue of securities

A foreign corporation with a primary listing must ensure that as far as reasonably practicable, all new issues of securities are admitted and quoted on the Exchange on the same day as they are admitted and quoted on the other stock exchange(s).

PART D - ADMISSION REQUIREMENTS FOR A SECONDARY LISTING**4A.19 Introduction**

- (1) Unless the context requires otherwise, an “**applicant**” in this Part D means a corporation seeking a secondary listing on the Main Market.
- (2) An applicant is subject to the listing rules (or its equivalent) of ~~the-its~~ home exchange.

- (3) Apart from the requirements set out in this Chapter, Chapters 1, 2 and 16, where applicable, and such other requirements as may be imposed by the Exchange from time to time, the other Chapters of these Requirements are not applicable to the applicant.

4A.20 Admission

- (1) The Exchange will exercise discretion over the admission and continued listing of securities on its Official List and may approve or reject applications for listing on the Main Market, as it deems fit.
- (2) The Exchange may also approve applications for listing on the Exchange unconditionally or subject to such conditions, as it deems fit.
- (3) An applicant must also comply with the relevant admission procedures and requirements as may be prescribed by the Exchange.

[Cross reference: Practice Note ~~s 21;~~ ~~Practice Note and 24~~]

4A.21 Approval from other authorities

An applicant must first obtain approval(s) from the SC and other relevant authorities (where applicable) before listing and quotation of any security will be considered by the Exchange.

~~4A.22 Appointment of Directors~~

~~An applicant must have at least 1 director whose principal or only place of residence is within Malaysia.~~

~~4A.232 Other Obligations~~

Apart from the obligations set out in this Part D, an applicant must comply with paragraphs 4A.03, ~~4A.04~~ and 4A.05, ~~with the necessary modifications.~~

PART E - SPECIFIC CONTINUING OBLIGATIONS RELATING TO CORPORATIONS WITH A SECONDARY LISTING

4A.243 Introduction

Apart from the requirements set out in this Chapter, Chapters 1, 2 and 16, where applicable, and such other requirements as may be imposed by the Exchange from time to time, the other Chapters of these Requirements are not applicable to a corporation with a secondary listing on the Main Market.

4A.254 New issue of securities by a corporation with a secondary listing

A corporation with a secondary listing must comply with the relevant procedures and requirements for a new issue of securities as may be prescribed by the Exchange.

[Cross-reference: Practice Note 25]

4A.265 ~~Directors~~Other obligations

A corporation with a secondary listing must comply with paragraphs s 4A.03, 4A.04 and 4A.05~~22~~ as a continuing listing obligationss.

4A.276 Change in classification

A corporation with a secondary listing must comply with paragraph 8.11 as if it were the listed issuer mentioned in paragraph 8.11.

4A.287 Documents for overseas securities holders

A corporation with a secondary listing must comply with paragraph 9.34 as if it were the listed issuer mentioned in that paragraph.

4A.298 Copies of documents to be supplied to the Exchange

The provisions of paragraph 9.35 apply and a corporation with a secondary listing must comply with paragraph 9.35 as if it were the listed issuer mentioned in that paragraph.

4A.309 Director's undertaking

A corporation with a secondary listing must ensure that every director of the corporation gives the Exchange after this paragraph comes into force or his appointment, whichever is the later, and in any event not later than 14 days after that, an undertaking in the form as may be prescribed by the Exchange.

[Cross reference: Annexures [PN241-C](#) and [PN21-D](#) of Practice Note [214](#)]

4A.310 Other obligations

Apart from the obligations set out in this Part E, a corporation with a secondary listing must comply with the following requirements, with the necessary modifications:

- (a) paragraph 4A.09;
- (b) paragraph 4A.10;
- (c) paragraph 4A.11;
- (d) paragraph 4A.12;
- (e) paragraph 4A.13;
- (f) paragraph 4A.15;
- (g) paragraph 4A.17; and
- (h) paragraph 4A.18.

[End of Chapter]

CHAPTER 4B LISTING UNDER AN EXEMPT REGIME**PART A – GENERAL****4B.01 Introduction**

This Chapter sets out the requirements that must be complied with by an issuer seeking a listing of its sukuk and debt securities on the Exchange under an Exempt Regime, and the continuing listing obligations of such issuer.

PART B - DEFINITIONS**4B.02 Definitions**

For the purpose of this Chapter, unless the context otherwise requires -

- (a) **“Exempt Regime”** means a regime under which the sukuk or debt securities are offered, issued or subscribed in accordance with section 229(1) or section 230(1) of the CMSA, and are listed but not quoted for trading on the Exchange;
- (b) **“government”** includes -
 - (i) the Federal or State government of Malaysia;
 - (ii) Bank Negara Malaysia;
 - (iii) a foreign government; or
 - (iv) a foreign central bank;
- (c) **“Information Memorandum/Offering Circular”** means a document which is issued by an issuer or its agent purporting to describe the business and affairs of the issuer and to provide the investors information on the offering of the sukuk or debt securities;
- (d) **“issuer”** means an issuer, listed or otherwise, whose sukuk or debt securities are listed or proposed to be listed on the Exchange under an Exempt Regime;
- (e) **“material information”** means information which is reasonably expected to have a material effect on -
 - (i) the price or value of the issuer's sukuk or debt securities; or
 - (ii) the decision of a sukuk or debt securities holder or an investor whether to trade in such debt securities;
- (f) **“sukuk”** means Islamic securities as defined in the SC's Guidelines on the Offering of Islamic Securities;
- (g) **“Trust Deed”** means the trust deed governing an issue of the sukuk or debt securities entered into between the issuer and the sukuk or debt securities holders in accordance with the SC's Guidelines on Minimum Contents Requirements for Trust Deeds; and
- (h) **“Trustee”** means the trustee appointed pursuant to the terms of the Trust Deed.

PART C - ADMISSION**4B.03 Approval for admission**

- (1) An issuer must submit its listing application under this Chapter through a corporate finance adviser that may act as a principal adviser under the SC's Principal Adviser Guidelines.
- (2) An issuer seeking to list any sukuk or debt securities on the Exchange under an Exempt Regime needs to obtain the approval of the SC only if an approval under section 212(4) of the CMSA is required for the issue or offer of the sukuk or debt securities.
- (3) Where the sukuk or debt securities are issued under a programme, an issuer may list either all or a certain class or tranche of sukuk or debt securities issued under the programme.
- (4) Short-term sukuk or debt securities with original maturity date of less than 1 year cannot be listed.
- (5) The Exchange will exercise discretion over the admission and continued listing of the sukuk or debt securities on the Exchange under an Exempt Regime and may approve or reject applications for listing, as it deems fit.
- (6) An issuer must comply with the relevant admission procedures and requirements as may be prescribed by the Exchange.

[Cross reference: Practice Note 26]

4B.04 Information Memorandum/Offering Circular required

- (1) An issuer must issue an Information Memorandum/Offering Circular in connection with the listing.
- (2) Notwithstanding subparagraph (1) above, where sukuk or debt securities are -
 - (a) issued, or offered or guaranteed by a multilateral development bank, a multilateral financial institution, any government or entities wholly-owned by the government; or
 - (b) issued by a special purpose vehicle which is established by a multilateral development bank, a multilateral financial institution, any government or entities wholly-owned by the government and where the ultimate credit risk exposures of the investors still reside with these entities,

the issuance of a document setting out the principal terms and conditions of the sukuk or debt securities will be acceptable in place of an Information Memorandum/Offering Circular.

4B.05 Financial statements and announcements

- (1) An issuer must issue its financial statements and announcements in English.
- (2) The issuer may prepare its financial statements in accordance with the approved accounting standards applicable in its home jurisdiction.

PART D - CONTINUING LISTING OBLIGATIONS**4B.06 Disclosure of information**

- (1) An issuer must immediately announce to the Exchange any material information.

-
- (2) Without limiting the generality of subparagraph (1) above, an issuer must immediately announce to the Exchange the following:
- (a) any change in the terms of the sukuk or debt securities;
 - (b) any redemption or cancellation of the sukuk or debt securities;
 - (c) any amendment to the Trust Deed, if applicable;
 - (d) any appointment or replacement of Trustee or fiscal agent, if applicable; and
 - (e) any change of its Shariah adviser appointed by the issuer as required under the SC's Guidelines on the Offering of Islamic Securities.
- (3) An issuer must, at least 1 month ~~prior to~~before the maturity date, announce the maturity date of each issuance of sukuk or debt securities.
- (4) An issuer which is a foreign corporation must announce to the Exchange concurrently all information required to be publicly disclosed to its domestic regulatory authorities and other stock exchanges, if applicable.

4B.07 Submission of financial statements

- (1) An issuer must announce its unaudited or audited financial statements covering the profit and loss position and the balance sheet position on a consolidated basis within 2 months after the close of the half year of the issuer's financial year, if any, which statements must state whether there is any abnormal circumstance that has affected or will affect the business and financial position of the issuer.
- (2) An issuer must issue to its sukuk or debt securities holders and give to the Exchange, the issuer's annual audited financial statement, within 4 months after the close of the financial year of the issuer.
- (3) Subparagraphs (1) and (2) above ~~do~~es not apply to an issuer referred to in paragraph 4B.05~~4~~(2) above.

4B.08 Financial statements and announcements

An issuer must comply with paragraph 4B.05 as a continuing listing obligation.

4B.09 Other Chapters not applicable

- (1) Save as stated below, all provisions in Chapters 1, 2 and 16 apply to an issuer, as if it were a listed issuer, with the necessary modifications:
- (a) paragraph 2.03(1);
 - (b) paragraph 2.09;
 - (c) paragraph 16.02;
 - (d) paragraph 16.03;
 - (e) paragraph 16.04;
 - (f) paragraph 16.06;
 - (g) paragraph 16.07;

- (h) paragraph 16.12;
 - (i) paragraph 16.13; and
 - (j) paragraph 16.22.
- (2) Apart from the above, the other Chapters of these Requirements are not applicable to an issuer of sukuk or debt securities under this Chapter.

PART E – DE-LISTING BY THE EXCHANGE

4B.10 De-listing by the Exchange

In addition to the circumstances set out in paragraph 16.11, the Exchange may at any time de-list an issuer or any class of its sukuk or debt securities from the Official List in any of the following circumstances:

- (a) upon the occurrence of any of the events which the Trustee has declared the sukuk or debt securities to be immediately due and repayable pursuant to the Trust Deed; or
- (b) upon the maturity or expiry of the sukuk or debt securities.

[End of Chapter]

CHAPTER 5 STRUCTURED WARRANTS**PART A - GENERAL****5.01 Introduction**

This Chapter sets out the requirements that must be complied with by an issuer seeking a listing of its structured warrants on the Official List and the continuing listing obligations of such issuer.

PART B - DEFINITIONS**5.02 Definitions**

For the purpose of this Chapter, unless the context otherwise requires -

American style	in respect of the right of a person under structured warrants, means the ability to exercise that right any time before or on expiry date.
Approved Securities	has the meaning given in Rule 704.1 of the Rules of the Exchange.
bull equity-linked structure	means a contract under which a person has an actual, contingent or prospective right to receive on settlement date - <ul style="list-style-type: none"> (a) a predetermined amount in the form of cash where the closing price of the underlying shares on expiry date is at or above the strike price; or (b) a specified number of the underlying shares or an amount in the form of cash calculated by reference to the value of the underlying shares where the closing price of the underlying shares on expiry date is below the strike price.
call warrant	means a contract under which a person has an actual, contingent or prospective right to  <ul style="list-style-type: none"> (a) buy a specified number or units of underlying shares or exchange-traded fund at a specified price on or by a specified future date; or (b) receive an amount in the form of cash or other property, depending on the state of affairs that relate to fluctuations in the value or price of an underlying financial instrument, and the amount will be calculated in a particular manner by reference to that state of affairs in accordance with the contract.
Clearing House	means Bursa Malaysia Securities Clearing Sdn Bhd and any other clearing house as may be designated by the Exchange from time to time in accordance with Rule 801.2 of the Rules of the Exchange.
closing price	in relation to a bull equity-linked structure, means the closing price of the underlying shares on the market day immediately before the expiry date.
date of issue	means the date that a structured warrant issue is offered.

eligible brokers	means individually or collectively investment banks, universal brokers, special scheme brokers and eligible non-universal brokers.
eligible non-universal broker	means a non-universal broker which has merged with or acquired, as the case may be, the assets or any interests and business of at least one other member company(ies) and/or Participating Organisation(s).
European style	in respect of the right of a person under structured warrants, means the ability to exercise that right on expiry date.
exchange-traded fund	means a listed index-tracking fund structured as a unit trust scheme or any other approved structures whose primary objective is to achieve returns that correspond to the performance of a particular index.
exercise price or strike price	in relation to a particular structured warrant, means the pre-specified price at which the holder of such warrants may exercise the right under such structured warrants.
expiry date	in respect of the right of a person under a structured warrant, means the date in which the ability to exercise that right expires.
fully-collateralised call warrants	means call warrants which fulfil the following: <ul style="list-style-type: none"> (a) the underlying financial instrument is shares listed on the Exchange; (b) the issue of the call warrants is accompanied by a deposit of all shares which is the subject of such warrants; and (c) a custodian or trustee is appointed for the entire term of the warrants in issue.
in-the-money	in respect of call warrants, refers to a market situation where the price of the underlying financial instrument is higher than the exercise price or strike price.
investment bank	means an investment bank as referred to under the Guidelines on Investment Banks and which is registered as a Participating Organisation in accordance with the Rules of the Exchange, unless the context otherwise permits.
issuer	means an issuer of structured warrants which are listed or proposed to be listed on the Official List.
licensed institution	has the same meaning given in the Banking and Financial Institutions Act 1989.
Market Maker	means a person who performs market making and is registered as a market maker under the Rules of the Exchange.
market making	means the act of entering bid and offer prices in the Automated Trading System of the Exchange.
non-collateralised structured warrants	means structured warrants where the underlying financial instrument is not held in deposit by a custodian or trustee as approved by the SC for the entire term of the warrants in issue.

performance guarantee	in relation to an issuer, means an unconditional and irrevocable guarantee to perform any and-or all of the issuer's obligations in the terms and conditions of the structured warrants issue in the event the issuer fails to perform such obligations.
prospectus	has the same meaning given in the CMSA and, for the purpose of this Chapter, includes the term "base prospectus" and "term sheet".
put warrant	means a contract under which a person has an actual, contingent or prospective right to – (a) sell a specified number or units of underlying shares or exchange-traded fund at a specified price on or by a specified future date; or (b) receive an amount in the form of cash, depending on the state of affairs that relate to fluctuations in the value or price of an underlying financial instrument, and the amount will be calculated in a particular manner by reference to that state of affairs in accordance with the contract.
settlement date	in relation to a bull equity-linked structure, means the date upon which the payment or delivery of underlying shares, as the case may be, is made to the holder of such issue.
shares	means shares of a corporation listed on the Exchange or a securities exchange outside Malaysia.
special scheme broker	means a foreign stockbroking company established under the Application for Establishment of Foreign Stockbroking Companies Under the Special Scheme.
structured warrants	means individually or collectively as the context may require, the call warrants, put warrants, basket warrants, bull equity-linked structures or such other structures that may be specified by the Exchange from time to time.
underlying corporation	in relation to structured warrants, means the corporation that has issued the shares, which is the subject of such warrants.
underlying financial instrument	in relation to structured warrants, means the shares, exchange-traded fund or index, which is the subject of such warrants.
underlying index	in relation to structured warrants, means the index which is the subject of such warrants.
underlying shares	in relation to structured warrants, means the shares which is-are the subject of such warrants.
universal broker	means a Participating Organisation which has – (a) merged with or acquired, as the case may be, 3 or more other former member company(ies) or Participating Organisations; (b) fulfilled the necessary qualifying criteria from time to time stipulated by the SC, the Exchange or both, to the satisfaction of the SC, the Exchange or both; and

- (c) been approved in writing by the SC to be a universal broker.

PART C – UNDERLYING FINANCIAL INSTRUMENT

5.03 Underlying financial instrument listed on the Exchange

- (1) Where the underlying financial instrument of structured warrants is shares or an exchange-traded fund listed on the Exchange, an issuer must ensure that the underlying corporation or exchange-traded fund has an average daily market capitalisation (excluding treasury shares) of at least -
- (a) RM1 billion in the past 3 months ending on the last market day of the calendar month immediately preceding the date of issue; or
 - (b) RM3 billion for newly listed corporations or exchange-traded funds that do not meet the 3 month market capitalisation track record.
- (2) In the case of an issue of structured warrants where the underlying financial instrument is shares, an issuer must ensure that the underlying corporation is in compliance with the Exchange's public shareholding spread requirement.

5.04 Underlying financial instrument listed outside Malaysia

Where the underlying financial instrument of the structured warrants is shares or an exchange-traded fund listed on a securities exchange outside Malaysia, an issuer must ensure that the underlying financial instrument satisfies the following criteria:

- (a) ~~The~~ underlying corporation or exchange-traded fund is listed on a securities exchange which is a member of the World Federation of Exchanges or is approved by the Exchange;
- (b) ~~The~~ underlying corporation or exchange-traded fund must have an average daily market capitalisation equivalent to at least -
 - (i) RM3 billion in the past 3 months ending on the last market day of the calendar month immediately preceding the date of issue; or
 - (ii) RM5 billion for newly listed corporations or exchange-traded fund that does not meet the 3 month market capitalisation track record;
- (c) ~~The~~ underlying corporation or exchange-traded fund must be in compliance with the listing rules and requirements of its home exchange at the date of issue; and
- (d) ~~I~~nformation on the price, volume, financial information and price-sensitive information relating to the underlying corporation or exchange-traded fund must be available to investors in Malaysia.

5.05 Index as underlying financial instrument

~~(1)~~ — Where the underlying financial instrument of the structured warrants is an index, ~~;~~

~~(1)~~ an issuer must ensure that the index is either based on the Exchange or if it is based on a securities exchange outside Malaysia, it is approved by the Exchange; and

(2) ~~W~~here the index is based on a securities exchange outside Malaysia, information on its composition and performance must be made available to investors in Malaysia.

5.06 Underlying financial instrument for put warrants

- (1) Subject to compliance with paragraphs 5.03, 5.04 and 5.05 above, an issuer may issue put warrants based on an underlying financial instrument which is -
 - (a) shares or an exchange-traded fund listed on the Exchange or a securities exchange outside Malaysia; or
 - (b) an index, which composition and performance is based on the Exchange or a securities exchange outside Malaysia.
- (2) When an issuer issues put warrants based on underlying shares which are listed on the Exchange, the issuer must ensure that the underlying shares are part of the Approved Securities unless the said put warrant is issued together with a call warrant with the same underlying shares.

5.07 Acceptable securities exchange outside Malaysia

Where the underlying financial instrument of the structured warrants is listed on a securities exchange outside Malaysia, in determining whether the securities exchange is acceptable, the Exchange will consider among others, the following:

- (a) The market is regulated in a fair and orderly manner by the government or properly constituted body pursuant to a body of laws, regulations or rules which are broadly based;
- (b) Equality of the reporting and timeliness of the disclosure of information on price, volume, financial information and price-sensitive information; and
- (c) The availability of price information to investors in Malaysia.

5.08 Acceptable index

Where the underlying financial instrument of the structured warrants is an index, in determining whether the index is acceptable, the Exchange will consider among others, whether the index –

- (a) is broadly based;
- (b) has transparent components; and
- (c) is a recognised benchmark.

PART D – ADMISSION**5.09 Admission**

- (1) The Exchange will exercise discretion over the admission and continued listing of structured warrants on its Official List and may approve or reject applications for listing, as it deems fit.
- (2) The Exchange may also approve applications for listing unconditionally or subject to such conditions, as it deems fit.
- (3) An issuer applying to admit a structured warrant issue must comply with the relevant listing procedures and requirements as may be prescribed by the Exchange.

[Cross reference: Practice Note 27]

-
- (4) An issuer must submit its listing application to the Exchange for the issue of structured warrants through an eligible broker. However, where the issuers themselves are eligible brokers or licensed institutions approved by Bank Negara Malaysia, they may submit the proposals on their own behalf.

5.10 Approval from other authorities

- (1) An issuer seeking a listing of its structured warrants on the Official List must fulfill the eligibility criteria prescribed by the SC.
- (2) In addition, an issuer must obtain approval(s) from the other relevant authorities (where applicable) before listing and quotation of any structured warrants will be considered by the Exchange.

5.11 Holders of structured warrants

- (1) An issuer must ensure that, upon initial listing, the structured warrants for which listing is sought are in the hands of a minimum -
- (a) 100 warrant holders holding not less than 1 board lot of warrants each; or
 - (b) 50 warrant holders holding not less than 1 board lot each provided that each of these warrant holders subscribe for a minimum of RM100,000 of warrants each.
- (2) The requirements in subparagraph (1) above do not apply to –
- (a) an issuer of bull equity-linked structures; or
 - (b) an issuer who provides liquidity for the structured warrant issue via market making in accordance with paragraph 5.12 below.

5.12 Market making

An issuer intending to provide liquidity via market making must appoint only 1 Market Maker or be the Market Maker if it wishes to undertake the market making activities itself.

PART E – TERMS AND CONDITIONS

5.13 Maximum issue size

- (1) For structured warrants where settlement is –
- (a) by way of physical delivery; and
 - (b) the underlying financial instrument is shares or an exchange-traded fund listed on the Exchange,

the aggregate outstanding collateralised and non-collateralised structured warrants issued at any one time must not exceed 20% of the share capital of the underlying corporation or the fund size of the exchange-traded fund.

- (2) For the purpose of this paragraph, the aggregate outstanding collateralised and non-collateralised structured warrants issued include those already issued by third-party issuers on the same underlying shares that are still outstanding (unexercised and unexpired).
- (3) When computing the size of a structured warrant issue, an issuer must not include the company warrants issued by the underlying corporation.

5.14 Minimum issue size

An issuer must ensure that each issue of structured warrants is for a total face amount of not less than RM5 million.

5.15 Tenure of issue

An issuer must ensure that the expiry date of the structured warrants -

- (a) in relation to call and put warrants, is not earlier than 6 months and not later than 5 years from the date of issue; and
- (b) in relation to bull equity-linked structures, is not earlier than 28 days and not later than 2 years from the date of issue.

5.16 Take-over, Liquidation, Dissolution and Winding-Up

The terms and conditions of each issue of structured warrant must specify the rights of the warrant holders in the event of –

- (a) a take-over, merger, liquidation, dissolution or winding-up of the underlying corporation or issuer;
- (b) a scheme of arrangement involving the shareholders of the underlying corporation or issuer;
- (c) winding-up of the underlying exchange-traded fund; or
- (d) any other circumstances having a similar effect on the rights of warrant holders to any of the above events.

5.17 Adjustment

Where an issuer proposes an adjustment to the terms of the structured warrants arising from ~~the following (collectively referred to as “Corporate Proposals”)~~:

- (a) a corporate exercise undertaken by the underlying corporation or the issuer of the underlying financial instrument, for example a consolidation, bonus or rights issue; or
- (b) ~~upon the occurrence of~~ any event which has a dilutive or concentrative or other effect on the theoretical value of the underlying financial instruments,

(collectively referred to as “Corporate Proposals”)

the issuer may only adjust the exercise price, conversion ratio of its structured warrants, or both.

PART F - TRUST DEED/DEED POLL

5.18 Contents of trust deed or deed poll

- (1) An issuer must ensure that the trust deed or deed poll governing an issue of structured warrants includes the various provisions set out in Appendix 5A.
- (2) An issuer must furnish to the Exchange a letter of compliance pursuant to paragraph 2.12 together with the trust deed or deed poll and a checklist showing compliance with Appendix 5A.

PART G – TRADING**5.19 Minimum issue price**

The minimum issue price for a structured warrants issue must be RM0.15 per warrant.

5.20 Board lot

- (1) Trading of structured warrants must be in a board lot comprising 100 units or any other number of securities permitted by the Rules of the Exchange.
- (2) Structured warrants based on an index must be issued in board lots of 100 warrants.

5.21 Conversion Ratio

For the purpose of exercising structured warrants where settlement is by way of delivery of the underlying shares, the conversion ratio must be as follows:

- (a) 1 structured warrant for 1 share;
- (b) 10 structured warrants for 1 share; or
- (c) ~~S~~such other ratio as the Exchange may approve, provided it will convert to a whole number of a board lot of the underlying shares.

5.22 Exercise Style

- (1) Other than bull equity-linked structures, the right of the structured warrant holders must be exercisable in American style, European style or such other style as the Exchange may approve.
- (2) For bull equity-linked structures, the right is only exercisable in European style.

PART H – SETTLEMENT OF STRUCTURED WARRANTS**5.23 Mode of settlement**

- (1) An issuer must settle a structured warrants issue either -
 - (a) by way of delivery of the underlying shares or units of the exchange-~~r~~-traded fund; or
 - (b) in cash.
- (2) The issuer must specify the mode of settlement clearly in the terms and conditions of the structured warrants issue.
- (3) Subject to subparagraph (4) below, upon exercise by warrant holders or at the expiry date of a structured warrant issue, an issuer does not have the option to elect for an alternative mode of settlement.
- (4) Notwithstanding subparagraph (3) above, where –
 - (a) the mode of settlement is by way of delivery of underlying shares or units of the exchange-~~r~~-traded fund; and
 - (b) the warrant holders receive odd lots of shares upon exercise of the structured warrants or at expiry date,

the issuer must settle the said odd lots in cash.

5.24 Settlement by cash only

- (1) An issuer must settle a structured warrants issue in cash if the underlying financial instrument is –
 - (a) shares or an exchange-traded fund listed on a securities exchange outside Malaysia; or
 - (b) an index.
- (2) An issuer must specify the settlement by way of cash clearly in the terms and conditions of the structured warrants issue.

5.25 Settlement of bull equity-linked structures

Subject to paragraph 5.24, in relation to a settlement of bull equity-linked structures, the terms and conditions of the issue must clearly specify that the holders will receive on settlement date –

- (a) a predetermined amount in the form of cash if the closing price of the underlying shares on expiry date ~~is~~ at or above the strike price; or
- (b) delivery of underlying shares or an amount in the form of cash if the closing price of the underlying shares is below the strike price on expiry date. In this event, the cash will be calculated by reference to the value of those underlying shares.

5.26 Calculation of settlement price when settled by way of cash

- (1) Where settlement of a structured warrant issue is in the form of cash, an issuer must specify in the terms and condition of the structured warrants issue, the method of calculation in determining the settlement price, as ~~described below.~~ follows:
 - (a) ~~W~~where the underlying financial instrument is shares or an exchange-traded fund, the settlement price will be calculated using one of the following methods:~~:-~~
 - (i) the volume weighted average price; or
 - (ii) the average closing price; or
 - (iii) the closing price of the underlying share or exchange-traded fund on the market day immediately before the exercise or expiry date; and
 - (b) ~~W~~where the underlying financial instrument is an index, the settlement price must be calculated using one of the following methods:
 - (i) the closing level of the underlying index on the market day immediately before the exercise or expiry date; or
 - (ii) the final settlement price for settling the corresponding index futures contract on the expiry date; or
 - (iii) the average of the closing levels of the underlying index for the 5 market days prior to and including the market day immediately before the exercise or expiry date.
- (2) For the purpose of subparagraph (1)(a) above, the volume weighted average price or the average closing price of the underlying shares or exchange~~-~~traded fund will be computed

based on 5 market days immediately before the exercise or expiry date of the structured warrants, subject to any adjustment as may be necessary to reflect any capitalisation, rights issue, distribution or others.

5.27 Settlement price for American style structured warrants

- (1) Subject to subparagraph (2), for American style structured warrants, in addition to the methods of calculating the settlement price set out in paragraph 5.26, the following calculation method may be used:
- (a) where the structured warrant is exercised before 12.30 p.m., the settlement price must be calculated using -
- (i) the closing price of the underlying share or exchange-traded fund; or
 - (ii) the closing level of the underlying index,
- where applicable, on the day that the structured warrant is exercised; and
- (b) where the structured warrant is exercised on or after 12.30 p.m., the settlement price must be calculated using -
- (i) the closing price of the underlying share or exchange-traded fund; or
 - (ii) the closing level of the underlying index,
- where applicable, on the next day after the day when the structured warrant is exercised.
- (2) An issuer may only use the additional calculation method set out in subparagraph (1) if -
- (a) it has specified the same in the terms and condition of the structured warrants issue; and
 - (b) the structured warrants are exercised before the expiry date.⁵

5.28 Automatic settlement in cash

Where the settlement of the structured warrants issue is in the form of cash, an issuer must ensure that the terms and conditions of the structured warrants issue provide for automatic settlement (i.e. where^{by} warrant holders are not required to serve a notice of exercise to the issuer) if the call and put warrants expire in-the-money.

PART I – FURTHER ISSUE

5.29 Further Issue

- (1) An issuer may apply to list a further issue of its structured warrants ("**Further Issue**") which forms part of the existing listed series of the structured warrants ("**Existing Issue**"), subject to the following conditions:
- (a) the Further Issue is for the purpose of facilitating market making;
 - (b) the terms and conditions of the Existing Issue either permit the Further Issue or have been properly amended to give the issuer the right to issue and list one or more Further Issues;

-
- (c) the terms and conditions of the Further Issue and the Existing Issue must be identical except for the size and tenure of the issue; and
 - (d) the issuer holds not more than 50% of the Existing Issue at the time of application for the Further Issue.
- (2) An issuer may retain up to 100% of the Further Issue at the date of listing of the Further Issue.
 - (3) For the avoidance of doubt, the requirements under paragraphs 5.14, 5.15 and 5.19 are not applicable to a Further issue.

5.30 Listing application for Further Issue

An issuer must comply with the relevant listing procedures and requirements for the listing of Further Issue as may be prescribed by the Exchange.

[Cross reference: Practice Note 27]

PART J – ISSUE OF BASKET WARRANTS

5.31 Basket warrants

Basket warrants are call or put warrants that are issued on a basket of 2 or more underlying shares.

5.32 Issuance of basket warrants

An issuer may issue basket warrants subject to the relevant terms and conditions applicable to the issue of structured warrants set out in this Chapter, with the following additional requirements:

- (a) For fully-collateralised issue of basket call warrants, the settlement may either be by way of delivery of the underlying shares or cash settlement; and
- (b) For non-collateralised issue of basket call or put warrants, the settlement must be by way of cash settlement only.

PART K - CONTINUING LISTING OBLIGATIONS

5.33 Obligation to retain a Market Maker

- (1) An issuer who provides liquidity for structured warrants via market making must ensure that the market making obligations, whether performed by itself or by another party, are performed -
 - (a) in accordance with the Rules of the Exchange; and
 - (b) as disclosed in the prospectus in relation to the minimum presence, spread and quantity requirements of the structured warrants.
- (2) For the avoidance of doubt, an issuer which has fulfilled the requirements in paragraph 5.11(1) above may also provide liquidity for its structured warrants via market making. In such instance, the issuer must also ensure that the Market Maker and market making activities comply with subparagraph (1) above.

5.34 Submission of financial statements

- (1) Subject to subparagraph (2) below, an issuer must announce its unaudited/audited financial statements covering the profit and loss position and the balance sheet position on a consolidated basis within 3 months after the close of the half year of the issuer's financial year ("**Due Date**"), or such period as may be approved by the Exchange. The issuer must ensure that the financial statement states whether there is any abnormal circumstance that has affected or will affect the business and financial position of the issuer.
- (2) This obligation does not apply to an issuer of bull equity-linked structures with an expiry date which takes place before the Due Date.
- (3) An issuer must immediately announce to the Exchange full details of any financial information which the issuer discloses to the public.

5.35 Submission of periodic information

- (1) Subject to subparagraph (2) below, an issuer must announce the following information to the Exchange ~~the following information~~, within the timeframes stipulated in subparagraph (2) below.
 - (a) the number of structured warrants exercised during the relevant timeframe;
 - (b) the cumulative number of structured warrants exercised to date; and
 - (c) the number of structured warrants outstanding.
- (2) The timeframes referred to in subparagraph (1) above are -

	Expiry date of Structured Warrants having an expiry date of -	Timeframes for A announcement
(a)	28 days	On a weekly basis, on the first market day of the week.
(b)	More than 28 days but 6 months or less	On a fortnightly basis, on the first market day of the week.
(c)	More than 6 months	On a monthly basis, within the first 5 market days of the month.

- (3) Subparagraph (1) above does not apply to structured warrants exercisable in an European style.
- (4) If an issuer provides liquidity via a market making, the issuer must announce the following information within the first 5 market days of every month:
 - (a) stock short name;
 - (b) stock code;
 - (c) number of structured warrants bought and the volume weighted average price of structured warrants bought in the preceding month;
 - (d) number of structured warrants sold and the volume weighted average price of structured warrants sold in the preceding month;

- (e) number of outstanding structured warrants in the market and the percentage of the same; and
 - (f) total issue size.
- (5) An issuer must also announce the number of structured warrants not held by the issuer or its Market Maker and the percentage of the same, on a quarterly basis.

5.36 Notice of expiry

- (1) An issuer of structured warrants must prepare and announce a notice of expiry stating the expiry date of the structured warrants and treatment of the structured warrants which are not exercised, within the following timeframes, as may be applicable:
- (a) where the structured warrants have an expiry date of 28 days but not more than 6 months - 2 weeks before the expiry date; or
 - (b) in respect of structured warrants other than those referred to in subparagraph (a) above - not less than 1 month before the expiry date.
- (2) In addition to subparagraph (1) above, an issuer of structured warrants without an automatic exercise feature must also despatch the above notice of expiry to its structured warrant holders.

5.37 Director's undertaking

An issuer of listed structured warrants must ensure that every director of the issuer gives the Exchange immediately after his appointment, and in any event not later than 14 days after the appointment, an undertaking in a form as may be prescribed by the Exchange.

[Cross reference: Annexure PN27-D of Practice Note 27]

5.38 Allotment of securities, despatch of notices of allotment for exercise and cash payment

Within 7 market days of the date a notice of exercise is received by the issuer together with the requisite payment (if any), or the expiry date, as the case may be, or such other period as may be prescribed by the Exchange -

- (a) where settlement of the structured warrants is by way of delivery of the underlying shares, an issuer must -
 - (i) cause the securities to be credited into the securities accounts of the structured warrants holders; and
 - (ii) despatch notices of allotment to the structured warrants holders; and
- (b) where settlement of the structured warrants is by way of cash payment, an issuer must make the payment to the structured warrants holders.

5.39 Full exercise before expiry

Where a structured warrant has been fully exercised before expiry, an issuer is required to immediately notify the Exchange of the full exercise.

5.40 Issuers incorporated in a jurisdiction outside Malaysia

- (1) In relation to an issuer incorporated in a jurisdiction outside Malaysia which is eligible and has been approved by the SC to issue ~~non-collateralised-call~~structured warrants, such an issuer must comply with the following provisions:
- (a) paragraph 4A.03
 - (b) paragraph 4A.09;
 - (c) paragraph 4A.10;
 - (d) paragraph 4A.15;
 - (e) paragraph 4A.16; and
 - (f) paragraph 9.34.
- (2) For the purpose of this paragraph, all references to a foreign corporation with primary listing on the Main Market in subparagraphs (1)(a) to (e) above and all references to listed issuer in paragraph 9.34 mean an issuer incorporated in a jurisdiction outside Malaysia.

5.41 Request for suspension, resumption of trading or withdrawal of listing

Where the underlying corporation or the underlying financial instrument is listed on a securities exchange outside Malaysia, the issuer must immediately request for a suspension, resumption in trading or withdrawal of listing, as the case may be if –

- (a) the underlying corporation or issuer of the underlying financial instrument announces that it has requested a suspension, resumption in trading or withdrawal of listing on the securities exchange; or
- (b) the suspension, resumption in trading or withdrawal is imposed or effected by the relevant securities exchange.

5.42 Other continuing obligations

Apart from Chapters 1, 2 and 16, the other Chapters of these Requirements are not applicable to an issuer of structured warrants.

PART L - ANNOUNCEMENTS**5.43 Announcement relating to adjustment to structured warrants**

- (1) Where an issuer proposes an adjustment to the terms of the structured warrants arising from a Corporate Proposal defined in paragraph 5.17 above, the issuer must, not later than 3 market days from the date of announcement of the Corporate Proposal by the underlying corporation or the issuer of the underlying financial instrument, announce to the Exchange the following information:
- (a) the salient terms and conditions of the Corporate Proposals which will result in the adjustment; and
 - (b) the adjustments that will be made to the structured warrants due to the Corporate Proposals.

-
- (2) Any adjustment to the structured warrants pursuant to subparagraph (1) above may only be made in accordance with paragraph 5.17 above.
- (3) An issuer must, not later than 3 market days from the date of announcement of the books closing date by the underlying corporation or the issuer of the underlying financial instrument, announce to the Exchange the following information:
- (a) the books closing date for the adjustments;
 - (b) the details of the adjustments; and
 - (c) in respect of a foreign underlying corporation or underlying financial instrument, the ex-entitlement date, which must be consistent with the foreign underlying corporation's or underlying financial instrument's ex-entitlement date.
- (4) Where an issuer adjusts the terms of the structured warrants or distributions to the holders of the structured warrants pursuant to events other than the Corporate Proposals, the issuer must immediately announce the following information:
- (a) the occurrence of the events, details and reasons of such adjustments or distributions; and
 - (b) the books closing date for the adjustments, and in respect of a foreign underlying corporation or underlying financial instrument, the ex-entitlement date (which must be consistent with the foreign underlying corporation's or underlying financial instrument's ex-entitlement date).
- (5) In respect of the adjustments made pursuant to subparagraph (4) above, an issuer must ensure that the period from it announcing the books closing date to the books closing date is not less than 10 market days.
- (6) An issuer must announce the adjusted exercise price, conversion ratio or both, and other salient terms of the structured warrants as soon as practicable and in any event not later than the last market day before the ex-entitlement date of the underlying financial instrument.

5.44 Announcement relating to market making

An issuer that provides liquidity via market making must immediately announce to the Exchange if –

- (a) the Market Maker of its structured warrants -
 - (i) does not carry out market making activities pursuant to the circumstances disclosed in the prospectus;
 - (ii) does not carry out market making activities pursuant to the exceptional circumstances described in the Rules of the Exchange; or
 - (iii) resumes market making activities after the occurrence of the events in subparagraphs (a)(i) or (ii) above; ~~and~~
- (b) there is any change in the Market Maker arising from resignation or termination of the Market Maker.

5.45 Announcement relating to dealing in structured warrants

- (1) For the purpose of this paragraph -

-
- (a) **"dealing"** means one or more of the following actions, undertaken by the issuer, its director or principal officer as a principal:
- (i) acquiring or disposing of structured warrants or any interest in structured warrants; ~~or~~
 - (ii) subscribing for or underwriting structured warrants;
 - (iii) making or offering to make with any person, or inducing or attempting to induce any person to enter into or to offer to enter into -
 - (aa) any agreement for or with a view to acquiring or disposing of structured warrants or any interest in structured warrants;
 - (bb) any agreement for or with a view to subscribing for or underwriting structured warrants; or
 - (cc) any agreement the purpose or avowed purpose of which is to secure a profit to any of the parties from the yield of structured warrants or by reference to fluctuations in the values of structured warrants; and
 - (iv) granting, accepting, acquiring, disposing of, exercising or discharging an option (whether for the call or put or both) or any other right or obligation, present or future, conditional or unconditional, to acquire or dispose of structured warrants or any interest in structured warrants;
- (b) **"interest in structured warrants"** has the same meaning as assigned to "interest in securities" under section 4 of the CMSA; and
- (c) **"principal officer"** in relation to an issuer, includes the chief executive who is not a director, the chief financial officer or any other employee who has access or is privy to price-sensitive information concerning the structured warrants.
- (2) An issuer must announce to the Exchange any dealing in the issuer's structured warrants by the following persons:
- (a) the issuer;
 - (b) the issuer's director; or
 - (c) the issuer's principal officer.
- (3) An issuer must announce the dealings referred to in subparagraph (2) above which takes place -
- (a) between the launching and listing date of that structured warrants, on the listing date of the structured warrants; and
 - (b) after the listing date, within the timeframe stipulated in paragraph 5.35(2).
- (4) An issuer must include the following information in the announcement referred to in subparagraph (2) above:
- (a) the name and position of the person involved in the dealing;
 - (b) the date on which the dealing occurred;
 - (c) the consideration for the dealing; and

-
- (d) the number of structured warrants involved in the dealing, both in absolute terms and as a percentage of the structured warrants.

PART M – IMPLEMENTATION OF PROPOSALS

5.46 Implementation deadline

- (1) An issuer must complete the implementation of a proposal relating to an issuance of structured warrants within 6 months from the date the listing application is approved by the Exchange.
- (2) If the issuer fails to complete the implementation of a proposal within the prescribed periods above, the Exchange's approvals given in regard to the proposal will lapse.
- (3) For a multiple issue of structured warrants, the issuer must ensure that the structured warrants are issued before the expiry date of the base prospectus.

[End of Chapter]

Appendix 5A
Contents of trust deed/deed poll for structured warrants

APPENDIX 5A**Contents of trust deed/deed poll in respect of structured warrants**
(paragraph 5.18)

- (1) Within 7 market days of the date a notice of exercise is received by the issuer together with the requisite payment (if any), or the expiry date, as the case may be, or such other period as may be prescribed by the Exchange –
 - (a) where settlement of the structured warrants is by way of delivery of the underlying shares, an issuer shall -
 - (i) cause the securities to be credited into the securities accounts of the structured warrants holders; and
 - (ii) despatch notices of allotment to the structured warrants holders; and
 - (b) where settlement of the structured warrants is by way of cash payment, an issuer shall make the payment to the structured warrants holders.
- (2) If a books closing date has been declared by the underlying ~~company corporation~~ and trading of the underlying shares is on a “cum-entitlement” basis, the underlying shares to be delivered by the issuer to the warrant holder upon the exercise of the structured warrants shall also be on a “cum-entitlement basis”.
- (3) Any suspension in the trading of the underlying shares will not preclude the warrant holder from exercising his rights.

[End of Appendix]

CHAPTER 6 NEW ISSUES OF SECURITIES**PART A - GENERAL****6.01 Introduction**

- (1) This Chapter sets out the requirements that must be complied with by an applicant or a listed issuer, as the case may be, for any new issue of securities.
- (2) If the new issue of securities is pursuant to or will result in a significant change in the business direction or policy of a listed corporation, the listed corporation must also comply with the requirements under this Chapter 6, where applicable.
- (3) Additional requirements relating to issuance of securities pursuant to acquisitions are set out in Chapter 10.
- (4) For the purpose of this Chapter, unless the context otherwise requires -
 - (a) a “**Specified Bonus Issue**” is a bonus issue of securities which -
 - (i) is not conditional upon any other corporate proposal, or
 - (ii) is conditional upon another corporate proposal but –
 - (aa) that other corporate proposal is a subdivision or consolidation ~~or of~~ shares; or
 - (bb) that other corporate proposal has been completed or become unconditional~~;~~
 - (b) a “**Specified Subdivision**” has the meaning given in paragraph 13.04(3); and
 - (c) a “**Specified Consolidation**” has the meaning given in paragraph 13.14.

PART B - ADMISSION**6.02 Admission**

- (1) The Exchange will exercise discretion over the listing of new issues of securities on its Official List and may approve or reject applications for the listing of such new issues of securities, as it deems fit.
- (2) Where the Exchange approves an application for the listing of a new issue of securities, such approval may be unconditional or subject to such conditions, as it deems fit.
- (3) In granting approval for the listing of a new issue of securities by listed issuers, the Exchange considers amongst others, whether -
 - (a) the approvals of the relevant authorities have been obtained, if any;
 - (b) shareholder approval is required under these Requirements;
 - (c) the listed issuer is under consideration for possible de-listing under Chapter 16;
 - (d) the listed issuer has satisfactory corporate governance practices;

- (e) the listed issuer has addressed all situations of conflict of interests satisfactorily; or
 - (f) the application by the listed issuer undermines public interest.
- (4) A listed issuer must submit a listing application under this Chapter to the Exchange through a Principal Adviser.
- (5) A listed issuer and its Principal Adviser must comply with the relevant listing procedures and requirements relating to a new issue of securities as may be prescribed by the Exchange.
- [Cross reference: Practice Note 28]*
- (6) The listed issuer, adviser or other persons accepting responsibility for all or any part of the information and documents submitted to the Exchange in relation to any listing application must exercise due diligence and comply with the SC's Guidelines on Due Diligence Conduct for Corporate Proposals as if the submission were made to the SC.

PART C - GENERAL REQUIREMENTS FOR NEW ISSUE OF SECURITIES

6.03 General mandate for issue of securities

- (1) Subject to paragraph 6.06 and notwithstanding the existence of a resolution pursuant to section 132D of the Companies Act 1965, or in relation to a foreign corporation, a resolution of a similar nature pursuant to the relevant laws of the place of incorporation, a listed issuer must not issue any shares or convertible securities if the nominal value of those shares or convertible securities, when aggregated with the nominal value of any such shares or convertible securities issued during the preceding 12 months, exceeds 10% of the nominal value of the issued and paid-up capital (excluding treasury shares) of the listed issuer except where the shares or convertible securities are issued with the prior shareholder approval in a general meeting of the precise terms and conditions of the issue.
- (2) In working out the number of shares or convertible securities that may be issued by a listed issuer, if the security is a convertible security, each such security is counted as the maximum number of shares into which it can be converted or exercised.
- (3) Where a general mandate for issue of securities is sought, the listed issuer must include in the statement accompanying the proposed resolution the following information:
- (a) whether such mandate is new or a renewal;
 - (b) where such mandate is a renewal or has been sought for in the preceding year, to specify the following:
 - (i) the proceeds raised from the previous mandate, if any;
 - (ii) the details and status of the utilisation of proceeds; and
 - (c) the purpose and utilisation of proceeds from the general mandate sought.

6.04 Issue of new securities under a general mandate

Subject to paragraph 6.05, where issuance of shares or convertible securities is made pursuant to paragraph 6.03(1), the listed issuer must ensure the following:

- (a) shares are not priced at more than 10% discount to the weighted average market price of the shares for the 5 market days immediately before the price-fixing date;

-
- (b) for issue of convertible securities –
- (i) if the exercise or conversion price is fixed, such price is not more than 10% discount to the weighted average market price of the underlying shares for the 5 market days immediately before the price-fixing date; and
 - (ii) if the exercise or conversion price is based on a formula, any discount in the price-fixing formula is not more than 10% of the weighted average market price of the underlying shares for the 5 market days immediately before exercise or conversion; and
- (c) securities are not placed to –
- (i) the interested director, interested major shareholder, interested chief executive or interested person connected with a director, major shareholder or chief executive (all as defined in paragraph 6.06); and
 - (ii) nominee corporations, unless the names of the ultimate beneficiaries are disclosed.

6.05 Issue of securities with specific shareholder approval

Where an issue of shares or other convertible securities departs from any of the applicable requirements stipulated in paragraph 6.04, the listed issuer must obtain the prior shareholder approval in a general meeting for the precise terms and conditions of the issue, in particular on –

- (a) the issue, exercise or conversion prices of the securities or, in a situation where such prices are to be determined after the date of shareholder approval, the basis or formula of determining such prices; and
- (b) the purposes of the issue and utilisation of proceeds.

6.06 Allotment of shares to directors etc

- (1) Except in the case of an issue of securities on a pro rata basis to shareholders or pursuant to a back-to-back placement undertaken in compliance with paragraph 6.14, a listed issuer must ensure that it or any of its subsidiaries does not issue shares or other convertible securities to the following persons unless shareholders in general meeting have approved the specific allotment to be made to such persons:
- (a) a director, major shareholder or chief executive of the listed issuer or a holding company of the listed issuer (“**interested director**”, “**interested major shareholder**” and “**interested chief executive**”); or
 - (b) a person connected with an interested director, interested major shareholder or interested chief executive (–“**interested person connected with a director, major shareholder or chief executive**”).
- (2) Notwithstanding any provision to the contrary in these Requirements, in a meeting to obtain shareholder approval in respect of the allotment referred to under subparagraph (1) above –
- (a) the interested director, interested major shareholder, interested chief executive or interested person connected with a director, major shareholder or chief executive; and
 - (b) where the allotment is in favour of an interested person connected with a director, major shareholder or chief executive, such director, major shareholder or chief executive,

must not vote on the resolution approving the said allotment. An interested director, interested major shareholder or interested chief executive must ensure that persons connected with him abstain from voting on the resolution approving the said allotment.

- (3) A listed issuer must include the following in the notice of meeting:
- (a) the number of securities to be so allotted;
 - (b) the purpose of allotment;
 - (c) the precise terms and conditions of the allotment; and
 - (d) the identity and relationship of the persons connected with the director, major shareholder or chief executive, where applicable.
- (4) Except in the case of an issue of securities on a pro rata basis to shareholders and subject to subparagraph (1) above, a listed issuer must ensure that its subsidiary does not issue shares or other convertible securities to a director, major shareholder or chief executive of the said subsidiary or the holding company of the said subsidiary (other than the listed issuer or a holding company of the listed issuer) or a person connected with such director, major shareholder or chief executive unless ~~—~~:
- (a) the listed issuer has obtained the prior approval of its board of directors for the specific allotment to such persons;
 - (b) the board of directors of the listed issuer has ensured that the allotment is fair and reasonable to the listed issuer and in the best interests of the listed issuer; and
 - (c) the listed issuer immediately announces the specific allotment to such persons and includes in the announcement:
 - (i) the information prescribed in subparagraph (3) above; and
 - (ii) a statement by the board of directors of the listed issuer that the allotment is fair and reasonable to the listed issuer and in the best interests of the listed issuer. Where a director disagrees with such statement, a statement by the director setting out the reasons and the factors taken into consideration in forming that opinion.

6.07 Announcement to the Exchange

- (1) A listed issuer must include the information set out in Part A of Appendix 6A in its announcement to the Exchange relating to a proposed new issue of securities.
- (2) Where a listed issuer is undertaking an issuance and placement of securities in stages over a period of time, the listed issuer must, upon placement of the securities, immediately announce to the Exchange, the number and issue price of the securities.

6.08 Circular

- (1) A listed issuer must include the information set out in Part A of Appendix 6B, in the circular to obtain the securities holder approval in respect of a new issue of securities.
- (2) The draft circular or in the case of a bonus issue, the circular must be submitted to the Exchange together with a checklist showing compliance with Part A of Appendix 6B.

6.09 Allotment of securities, despatch of notices of allotment and quotation application in respect of a public issue

Where a listed issuer issues securities to the public, within 8 market days of the final applications date or such other period as may be prescribed by the Exchange, a listed issuer must -

- (a) issue or allot the securities;
- (b) despatch notices of allotment to the successful applicants; and
- (c) apply for the quotation of such securities, where applicable.

6.10 Document for issue of securities to be made overseas

Where an issue of securities is to be made overseas and is supported by a prospectus or other public documents, a listed issuer must ensure that the prospectus or other public documents in English are lodged with the Exchange. Such documents must be endorsed with "Specimen – For Information Only."

PART D – REQUIREMENTS RELATING TO PLACEMENT**6.11 Additional requirements**

A listed issuer which intends to undertake a placement must comply with the provisions in this Part, in addition to those set out in Parts B and C of this Chapter, where applicable.

[Cross reference: Practice Note 28]

6.12 Placement agent

The Principal Adviser must act as the placement agent for placements of securities.

6.13 Payment of securities

The listed issuer must issue and allot securities as soon as possible after the price-fixing date. In any event, the listed issuer must ensure payments for the securities are made by the placees to the listed issuers within 5 market days from the price-fixing date. For issues of securities under paragraph 6.05, the price-fixing date will be taken as the date of shareholder approval, except in instances where the price is determined on a date subsequent to the shareholder approval.

6.14 Back-to-back placements

- (1) A listed issuer may undertake a back-to-back placement involving—
 - (a) an existing shareholder selling down existing shares of the listed issuer to a placement agent for subsequent placement to placees; and
 - (b) the listed issuer issuing new shares to the said existing shareholder to replace the shares sold earlier to the placement agent.
- (2) A listed issuer which undertakes a back-to-back placement must comply with the following conditions:
 - (a) the listed issuer has an average daily market capitalisation of at least RM500 million in the 3 months ending on the last business day of the calendar month immediately preceding the date of the placement;

- (b) the listed issuer complies with the shareholding spread requirements under paragraph 8.02(1); and
- (c) the listed issuer gives the Exchange a declaration from its existing shareholders involved in the back-to-back placement arrangement to the Exchange that they will not derive any financial benefit from such an arrangement, whether directly or indirectly.

6.15 Placees' details

- (1) As soon as practicable after the placement of securities and before the listing of such new issue of securities, the Principal Adviser must submit to the Exchange the following:
 - (a) the final list (broken down by each placement agent) setting out the names, home or business addresses, identity card/passport/company registration numbers, occupations/principal activities and securities account numbers of all the placees and the ultimate beneficial owners of the securities placed (in the case where the placees are nominee companies/corporations or funds), and the amount and price of securities placed to each placee; and
 - (b) a confirmation from the Principal Adviser that to the best of its knowledge and belief, after having taken all reasonable steps and made all reasonable inquiries, the details set out in the final list of placees in subparagraph (a) above are accurate and the issue or placement exercise complies with the requirements as stated in this Chapter.
- (2) The information on the ultimate beneficiaries of the securities as required in subparagraph (1)(a) above need not be submitted for the following types of placees:
 - (a) statutory institutions managing funds belonging to the general public;
 - (b) unit trust funds or collective investment schemes approved by the SC; and
 - (c) collective investment schemes which are authorised, approved or registered investment schemes incorporated, constituted or domiciled in a jurisdiction other than Malaysia and regulated by the relevant regulatory authority in that jurisdiction, subject to the Principal Adviser confirming to the Exchange that such schemes have been duly authorised, approved or registered.

6.16 Exchange's right for further information

The Exchange reserves the right to require the submission of further information on the issue or placement exercise and the placees if necessary, for establishing the propriety of the exercise and independence of the placees.

PART E - REQUIREMENTS RELATING TO A RIGHTS ISSUE

6.17 Additional Requirements

A listed issuer which intends to make a rights issue of securities must comply with the provisions in this Part in addition to those set out in Parts B and C of this Chapter, where applicable.⚠️

[Cross reference: Practice Note 28]

6.18 Underwriting

- (1) Underwriting arrangements in relation to a rights issue of securities are at the discretion of the listed issuer and its Principal Adviser.
- (2) The Principal Adviser submitting the application for listing to the Exchange must be part of the syndicate of underwriters for the securities offered under the rights issue if there is underwriting arrangement.
- (3) A listed issuer must disclose the following in its circular to shareholders:
 - (a) ~~T~~he minimum level of subscription and the basis for determining the minimum level based on factors, such as the level of funding required by the listed issuer; and
 - (b) ~~T~~he level of underwriting that has been arranged, together with justifications for the level arranged.
- (4) Where the minimum level of subscription is not achieved, the implementation of the rights issue of securities must be terminated and all consideration received must be immediately returned to all subscribers.
- (5) If certain shareholders wish to irrevocably undertake to subscribe for the securities offered under the rights issue, the listed issuer must ensure that -
 - (a) the shareholders have sufficient financial resources to take up the securities, as verified by an acceptable independent party, such as the listed issuer's Principal Adviser; and
 - (b) the shareholders consider the consequences of the rights issue with regard to the Take-Overs and Mergers Code, if applicable.

6.19 Requirements in relation to two-call rights issues

A listed issuer undertaking a two-call rights issue of securities by way of the capitalisation of reserves ~~arising from revaluation of assets~~ is subject to and must comply with the requirements set out in paragraphs 6.30 and 6.31 (where applicable), subject to such adaptations, where necessary.

6.20 A rights issue must be renounceable

A listed issuer must ensure that a rights issue allows for renunciation in part of or in whole in favour of a third party at the option of the entitled security holders.

6.21 Fixing of books closing date for a rights issue

- (1) A listed issuer must not fix a books closing date to determine persons entitled to participate in a rights issue until it has -
 - (a) obtained the Exchange's approval for the issue and listing of the right issue;
 - (b) obtained shareholder approval in general meeting for the rights issue; and
 - (c) executed the underwriting agreement, where applicable.
- (2) Notwithstanding subparagraph (1)(b) above, a listed issuer may fix a books closing date before it obtains the shareholder approval provided that -

-
- (a) the listed issuer's shareholders holding more than 50% of the aggregate of the nominal amounts of all the voting shares in the listed issuer have given their written irrevocable undertaking -
 - (i) to vote in favour of the rights issue during the general meeting; and
 - (ii) that they will not dispose off or otherwise reduce their shareholdings to 50% or below in any manner until after the general meeting to approve the rights issue is duly convened and passed;
 - (b) the listed issuer has submitted to the Exchange its shareholders' irrevocable undertakings referred to in subparagraph (a) above; and
 - (c) the listed issuer ensures that the last day of trading on a cum entitlement basis falls at least 1 market day after the date of the general meeting.

6.22 Notice of books closing date for a rights issue

A listed issuer must ensure that the period from the date it announces the books closing date for a rights issue to the books closing date is not less than 10 market days.

6.23 Timetable for a rights issue

- (1) A listed issuer must fix the closing date for the receipt of applications for and acceptance of the new securities to be issued pursuant to a rights issue ("**Rights Securities**") at least 11 market days after the books closing date.
- (2) Appendix 6C illustrates the timeline for a rights issue.

6.24 Announcements of important relevant dates of a rights issue

- (1) A listed issuer must, on the same day of announcing its books closing date for a rights issue, announce all the other important relevant dates relating to such rights issue as follows:
 - (a) date for commencement of trading of the rights;
 - (b) date for despatch of abridged prospectus and subscription forms;
 - (c) date for cessation of trading of the rights;
 - (d) last date of acceptance;
 - (e) date for excess Rights Securities application;
 - (f) date for payment;
 - (g) date for announcement of final subscription result and basis of allotment of excess Rights Securities;
 - (h) listing date of the Rights Securities;
 - (i) whether the Rights Securities will be listed and quoted as the existing securities of the same class or will be separately quoted on the listing date. If the Rights Securities will be separately quoted on the listing date, to specify the entitlement that the holders of the Rights Securities will not be entitled to; and
 - (j) such other important dates as the listed issuer may deem appropriate.

-
- (2) A listed issuer must undertake due care and diligence when announcing the relevant dates as set out in subparagraph (1) above. A listed issuer must immediately announce to the Exchange -
- (a) any change to the important relevant dates as announced pursuant to subparagraph (1) above; or
 - (b) any event that may result in the listed issuer being unable to comply with the important relevant dates as announced pursuant to subparagraph (1) above as soon as it becomes aware of such event,
- stating the change and reasons for such change.

6.25 Abridged Prospectus

A listed issuer must announce to the Exchange the abridged prospectus in respect of a rights issue duly registered by the SC and lodged with the Registrar of Companies, at least 1 market day before the commencement of trading of the rights.

6.26 Issue of notices of provisional allotment

A listed issuer must issue to the persons entitled within 2 market days, or such other period as the Exchange may approve after the books closing date -

- (a) the notices of provisional allotment; and
- (b) the rights subscription forms.

6.27 Availability of rights subscription forms

- (1) A listed issuer must make available sufficient copies of the rights subscription form at its registered office and share registrar's office to enable the acceptance of the rights.
- (2) A listed issuer must provide to each Participating Organisation a reasonable number of copies of the rights subscription form upon issue of the notices of provisional allotment and the rights subscription forms to the entitled persons.

6.28 Allotment of securities, despatch of notices of allotment and quotation application in respect of a rights issue

Within 8 market days after the final applications closing date for a rights issue or such other period as may be prescribed or allowed by the Exchange, a listed issuer must -

- (a) issue and allot the Rights Securities;
- (b) despatch notices of allotment to the allottees; and
- (c) apply for the quotation of such Rights Securities.

PART F - REQUIREMENTS RELATING TO A BONUS ISSUE

6.29 Additional Requirements

A listed issuer which intends to make a bonus issue of securities must comply with the provisions in this Part, in addition to those set out in Parts B and C of this Chapter, where applicable.

[Cross reference: Practice Note 28]

6.30 Criteria for bonus issues

- (1) A listed issuer intending to make a bonus issue of securities must ensure that the necessary reserves required for capitalisation of the bonus issue is unimpaired by losses on a consolidated basis, where applicable, based on the listed issuer's latest audited financial statements as well as its latest quarterly report.
- (2) Where a listed issuer intends to make a bonus issue of securities not from its retained profits but by way of the capitalisation of reserves arising from revaluation of assets, only the surplus arising from one or more of the following may be capitalised for the purpose of the bonus issue:
 - (a) revaluation of investments in subsidiaries or associated companies. In this respect, surplus arising from the revaluation of plant, machinery and equipment of the listed issuer's subsidiaries or associated companies must not be capitalised; **and**
 - (b) revaluation of real estates. In this instance, at least 20% of the valuation amount of the revalued real estates must be retained in the revaluation reserves after the capitalisation for the bonus issue.
- (3) A listed issuer must ensure that the available reserves for capitalisation are adequate to cover the entire bonus issue of securities. If the reserves for capitalisation are not based on the annual audited financial statements of the listed issuer such reserves must be verified and confirmed by the external auditors or reporting accountants of the listed issuer. Where a confirmation by the external auditors or reporting accountants is required, the reserves for capitalisation, which may be adjusted for subsequent events, must be based on the latest audited financial statements or the latest quarterly report, whichever is the later.

6.31 Valuation report for revaluation of real estates

- (1) Where the bonus issue is to be made by way of the capitalisation of reserves arising from revaluation of real estates under paragraph 6.30(2)(b), a listed issuer must –
 - (a) submit 2 copies of the valuation report on the real estate concerned to the Exchange and a copy of the valuer's undertaking letter in the form of Appendix 6D immediately after the listed issuer announces the bonus issue (if available) or as soon as the valuation report is ready. In any event, the listed issuer must submit the valuation report together with the valuer's undertaking letter to the Exchange at least 1 month before it issues its circular in relation to the bonus issue; and
 - (b) ensure that the date of valuation which forms the basis of the valuation certificate included in the circular is not more than 6 months before the date of the circular issued to shareholders.
- (2) A listed issuer and its valuer must ensure that the valuation report submitted pursuant to subparagraph (1) above complies with these Requirements and the SC's Asset Valuation Guidelines.
- (3) If the listed issuer or the valuer becomes aware of any circumstance or significant change which has or will have material effect on the content, validity or accuracy of its valuation report before the date of issuance of the circular, the valuer and the listed issuer must cause the valuation report to be updated. If the listed issuer fails to do so, the valuer must withdraw its consent to the inclusion of the valuation report in the circular.

-
- (4) Notwithstanding subparagraph (1) above, the Exchange may at its discretion and whenever it deems appropriate, at the cost of the listed issuer -
- (a) obtain a second opinion on the valuation report submitted by the listed issuer from another valuer appointed by the Exchange; or
 - (b) require a listed issuer to conduct a valuation on any asset.
- (5) A listed issuer and its valuer must comply with the instruction, directive or condition imposed by the Exchange and within such timeframe as may be specified by the Exchange.
- (6) The Exchange may refer any valuation report received by the Exchange to the SC for review. The listed issuer and its valuer must provide the Exchange or the SC on a timely basis, any information or assistance required in relation to the valuation report.
- (7) For the purposes of subparagraphs (1)(a), (2), (3) and (6) above, a “valuation report” includes a valuation certificate.

6.32 Staggered implementation of a bonus issue

- (1) A listed issuer may implement a bonus issue in stages over a period of time.
- (2) A listed issuer must include the information set out in Part A of Appendix 6A in its first announcement on the bonus issue to the Exchange, where applicable.
- (3) A listed issuer must subsequently announce each books closing date pursuant to paragraph 9.19(1) and include a statement that the listed issuer has adequate reserves to implement the bonus issue in the announcements.

6.33 Ranking of bonus issue securities

The bonus issue securities must rank pari passu in all respects with the existing securities of the same class upon listing.

6.34 Fixing of books closing date for a bonus issue

A listed issuer must not fix a books closing date to determine persons entitled to participate in a bonus issue until it has obtained -

- (a) the Exchange’s approval for the listing of the bonus issue; and
- (b) the shareholder approval in general meeting for the bonus issue.

6.35 Announcements in relation to a bonus issue of securities

- (1) A listed issuer must ensure that the period from the date it announces the books closing date for a bonus issue to the books closing date is not less than 10 market days.
- (2) A listed issuer must include the following when announcing the books closing date:-
 - (a) the maximum number of bonus issue securities which may be listed and quoted; and
 - (b) the date of listing and quotation.
- (3) Where the bonus issue is not a Specified Bonus Issue and the date of listing and quotation referred to in subparagraph (2)(b) above, (“**Relevant Date**”) cannot be ascertained at the time of announcement of the books closing date, the listed issuer must state that the Relevant

Date is dependent upon the other corporate proposal being completed or becoming unconditional.

- (4) Where the bonus issue is a Specified Bonus Issue, a listed issuer, must, on the books closing date, announce the exact number of bonus issue securities which will be listed and quoted.
- (5) Where the bonus issue is not a Specified Bonus Issue, immediately upon the other corporate proposal being completed or becoming unconditional and the listed issuer becoming aware of or ascertaining the Relevant Date, the listed issuer must announce -
 - (a) the exact number of bonus issue securities which will be listed and quoted; and
 - (b) the Relevant Date, if not previously announced.

PART G - REQUIREMENTS RELATING TO A SHARE SCHEME FOR EMPLOYEES

6.36 Additional Requirements

A listed issuer which intends to issue shares pursuant to a share scheme for employees must comply with the provisions in this Part, in addition to those set out in Parts B and C of this Chapter, where applicable.

[Cross reference: Practice Note 28]

6.37 Eligibility and allocation

- (1) Subject to the provisions set out in subparagraphs (2) and (3) below and paragraph 6.44, the board of directors of the listed issuer may determine the eligibility and allocation criteria under a share scheme for employees.
- (2) The listed issuer must ensure that participation in the scheme is restricted to directors and employees of the listed issuer's group.
- (3) The listed issuer must also ensure that -
 - (a) the aggregate allocation to directors and senior management does not exceed 50% of the total number of shares to be issued under the scheme; and
 - (b) the allocation to a director or employee who, either singly or collectively through persons connected with the director or employee, holds 20% or more of the issued and paid-up capital (excluding treasury shares) of the listed issuer, does not exceed 10% of the total number of shares to be issued under the scheme.
- (4) For the purpose of subparagraphs (2) and (3) above, unless the context otherwise requires -
 - (a) "**group**" means the listed issuer and its subsidiaries which are not dormant; and
 - (b) "**persons connected with an employee**" has the meaning given in relation to persons connected with a director or major shareholder as defined in paragraph 1.01.

6.38 Number of shares

- (1) The listed issuer must ensure that the total number of shares to be issued under a share scheme for employees is not more than 15% of its issued and paid-up capital (excluding treasury shares) at any one time.

-
- (2) For the purpose of subparagraph (1) above, where a listed issuer purchases its own shares or undertakes any other corporate proposal resulting in the total number of shares to be issued under the scheme exceeding 15% of its issued and paid-up capital (excluding treasury shares), no further options can be offered until the total number of shares to be issued under the scheme falls below 15% of its issued and paid-up capital (excluding treasury shares).

6.39 Pricing

The price payable for the shares under a share scheme for employees must be -

- (a) for an applicant implementing the scheme as part of its listing proposal, not less than the initial public offer price; or
- (b) for a listed issuer, based on the 5 day weighted average market price of the underlying shares at the time the option is offered, with a discount of not more than 10%.

6.40 Duration

A listed issuer must ensure that a share scheme for employees is for a duration of not more than 10 years.

6.41 Adjustments

A listed issuer must comply with the following as regards adjustments of price or number of shares to be issued under a share scheme for employees-:

- (a) a scheme may provide for adjustment of the subscription or option price or the number of shares (excluding options already exercised) under the scheme, in the event of a capitalisation issue, rights issue, bonus issue, consolidation or subdivision of shares, capital reduction or any other variation of capital;
- (b) any adjustments made must be in compliance with the provisions for adjustment as provided in the bylaws of the scheme;
- (c) the issue of securities as consideration for an acquisition, pursuant to a special issue or private placement must not be regarded as a circumstance requiring such adjustments; and
- (d) adjustments other than on a bonus issue must be confirmed in writing either by the external auditors or the listed issuer's Principal Adviser.

6.42 Bylaws

- (1) A listed issuer must include the provisions set out in Appendix 6E in the bylaws of a share scheme for employees.
- (2) The listed issuer must submit the final copy of the bylaws of the share scheme to the Exchange together with a letter of compliance pursuant to paragraph 2.12 and a checklist showing compliance with Appendix 6E.

6.43 Implementation

- (1) The effective date for the implementation of the scheme will be the date of full compliance with all relevant requirements in this Chapter including -:
- (a) submission of the final copy of the bylaws of the scheme to the Exchange pursuant to paragraph 6.42;

-
- (b) receipt of approval or approval-in-principle, as the case may be, for the listing of the shares to be issued under the scheme from the Exchange;
 - (c) procurement of shareholder approval for the scheme;
 - (d) receipt of approval of any other relevant authorities, where applicable; and
 - (e) fulfilment of all conditions attached to the above approvals, if any.
- (2) The listed issuer's Principal Adviser must submit a confirmation to the Exchange of full compliance pursuant to subparagraph (1) above stating the effective date of implementation together with a certified true copy of the relevant resolution passed by shareholders in general meeting.
- (3) The submission of the confirmation must be made not later than 5 market days after the effective date of implementation.

6.44 Share scheme for employees after listing

- (1) A listed issuer must ensure that all schemes whether implemented by the listed issuer or its subsidiary, involving the issue of shares to employees comply with the following:
- (a) the scheme is approved by the shareholders of the listed issuer in general meeting;
 - (b) the resolution approves a specific scheme and refers either to the scheme itself or to a summary of its principal terms included in the circular which contains all the provisions set out in Appendix 6E;
 - (c) unless the shares subject to the scheme are identical with other listed shares they are separately designated;
 - (d) where directors of the listed issuer are trustees of the scheme or have an interest, direct or indirect, in the scheme, the circular must disclose that interest; and
 - (e) where the scheme is implemented by a subsidiary, the bylaws of such scheme includes the provisions set out in Appendix 6E.
- (2) Subparagraph (1) does not apply to -
- (a) an applicant that is implementing a share scheme for employees -as part of its listing proposal; and
 - (b) share schemes for employees implemented by subsidiaries of the listed issuer which are listed on the ACE Market or a stock exchange deemed comparable by the Exchange.

6.45 Allotment of shares, despatch of notices of allotment and quotation application in respect of a share scheme for employees

Within 8 market days after the date of receipt of a notice of the exercise of the option together with the requisite payment or such other period as may be prescribed or allowed by the Exchange, a listed issuer must -

- (a) issue and/or allot shares;
- (b) despatch a notice of allotment to the employee of the listed issuer; and
- (c) apply for the quotation of such shares.

PART H - REQUIREMENTS RELATING TO AN ISSUE OF DEBT SECURITIES**6.46 Requirements relating to debt securities**

- (1) A listed issuer which intends to list debt securities must comply with the provisions in this Part, in addition to those set out in Parts B, C and E of this Chapter, where applicable.

[Cross reference: Practice Note 28]

- (2) The provisions in this Part apply to the listing of redeemable preference shares in the same way as it would apply to debt securities.
- (3) In the case of debt securities which are convertible into shares, the listed issuer must also comply with the provisions in Part I where applicable, in addition to the provisions in this Part.

6.47 Holders of debt securities

A listed issuer seeking a listing of its debt securities must have at least 100 holders of such debt securities holding not less than 1 board lot of the debt securities each.

6.48 Announcement relating to an issue of debt securities

In addition to the information set out in Part A of Appendix 6A, a listed issuer must include the information set out in Part B of Appendix 6A in its announcement to the Exchange relating to a proposed issue of debt securities.

PART I - REQUIREMENTS RELATING TO AN ISSUE OF CONVERTIBLE SECURITIES**6.49 Requirements relating to convertible securities**

A listed issuer which intends to issue convertible securities must comply with the provisions in this Part, in addition to those set out in Parts B, C and E of this Chapter, where applicable.

[Cross reference: Practice Note 28]

6.50 Maximum number of new shares allowed from exercise of warrants

A listed issuer must ensure that the number of new shares which will arise from all outstanding warrants, when exercised, does not exceed 50% of the issued and paid-up capital of the listed issuer (excluding treasury shares and before the exercise of the warrants) at all times.

6.51 Holders of convertible securities

A listed issuer seeking a listing of its convertible securities must have at least 100 holders of such securities holding not less than 1 board lot of the convertible securities each.

6.52 Announcement relating to an issue of convertible securities

In addition to the information set out in Part A of Appendix 6A, a listed issuer must include the information set out in Part C of Appendix 6A in its announcement to the Exchange relating to a proposed issue of convertible securities, where applicable.

6.53 Circular relating to an issue of convertible securities

- (1) In addition to the information set out in Part A of Appendix 6B, a listed issuer must ensure that the circular to the securities holders of the listed issuer to obtain the securities holder approval

in respect of an issue of convertible securities, includes the information set out in Part B of Appendix 6B.

- (2) The draft circular must be submitted to the Exchange together with a checklist showing compliance with Parts A and B of Appendix 6B.

6.54 Deed poll and trust deed to comply with Requirements

- (1) A listed issuer must furnish to the Exchange a letter of compliance pursuant to paragraph 2.12 together with the deed poll or trust deed, as the case may be.
- (2) A listed issuer must ensure that the deed poll or trust deed includes the various provisions set out in Appendix 6F.
- (3) A deed poll or trust deed must not include any provision for –
- (a) the extension or shortening of tenure of the convertible securities; or
 - (b) changes to the number of shares received for the exercise or conversion of each convertible security or changes to the pricing mechanism for the exercise or conversion price of the convertible security, except where these changes are adjustments following capitalisation issues, rights issue, consolidation or subdivision of shares or capital reduction exercises.

6.55 No alteration or adjustment to the terms

A listed issuer must ensure that no alteration or adjustment is made to the terms of the convertible securities during the tenure of the securities, unless such alteration or adjustment is provided upfront in the deed poll or trust deed governing the securities.

6.56 Consequential securities

- (1) Where a listed issuer intends to issue convertible securities arising from adjustments due to an issue of securities or a subdivision or consolidation of shares (referred to as “**consequential securities**” and “**principal securities**” respectively) -
- (a) the consequential securities must be listed and quoted simultaneously with the principal securities; and
 - (b) a listed issuer must ensure that the period from the date it announces the books closing date for the consequential securities to the books closing date is not less than 10 market days.
- (2) Where the consequential securities are due to -
- (a) a bonus issue of securities; or
 - (b) a Specified Subdivision or Specified Consolidation;
- the following applies:
- (i) a listed issuer need not submit to the Exchange any quotation application for the consequential securities;
 - (ii) when announcing the books closing date, a listed issuer must include -
 - (aa) the maximum number of consequential securities which may be listed and quoted; and

- (bb) the date of listing and quotation; and
 - (iii) the listed issuer must, on the books closing date, announce to the Exchange the exact number of consequential securities which will be listed and quoted.
- (3) Where the consequential securities are not due to a Specified Bonus Issue -
- (a) in relation to the announcement referred to in subparagraph 2(ii) above, if the date of listing and quotation (“**Relevant Date**”) cannot be ascertained at this time, the listed issuer must state that the Relevant Date is dependent upon the other corporate proposal being completed or becoming unconditional;
 - (b) subparagraph 2(iii) above does not apply; and
 - (c) immediately upon the other corporate proposal being completed or becoming unconditional and the listed issuer becoming aware of or ascertaining the Relevant Date, the listed issuer must announce to the Exchange -
 - (i) the exact number of consequential securities which will be listed and quoted; and
 - (ii) the Relevant Date, if not previously announced.

6.57 Notices of conversion or exercise

A listed issuer must include the following in a notice of conversion or exercise in respect of convertible securities:

- (a) the full title of the security;
- (b) the maturity date;
- (c) the conversion or exercise price;
- (d) the conversion or exercise period;
- (e) the mode of payment of the exercise price; and
- (f) the treatment of the security at maturity.

6.58 Allotment of securities, despatch of notices of allotment and quotation application in respect of conversion or exercise

Within 8 market days after the date of receipt of a subscription form together with the requisite payment or such other period as may be prescribed or allowed by the Exchange, a listed issuer must -

- (a) issue and/or allot -the securities arising from the conversion or exercise of the convertible security;
- (b) despatch a notice of allotment to the holder of the convertible security; and
- (c) apply for the quotation of such securities.

PART J - REQUIREMENTS RELATING TO REAL ESTATE INVESTMENT TRUSTS**6.59 Requirements relating to real estate investment trusts**

- (1) Except paragraphs 6.03, 6.06 and Part G of this Chapter, the provisions in this Chapter also apply in relation to the listing of a new issue of units of a real estate investment trust, subject to such adaptations, where necessary.

[Cross reference: Practice Note 28]

- (2) A real estate investment trust must procure the SC's approval for issuance and listing of new units before submitting a listing application to the Exchange.
- (3) Notwithstanding paragraph 6.30(2)(b) above, where a revaluation surplus is to be utilised for the issuance of bonus units by a real estate investment fund, up to 10% of the revalued amount must be retained in the revaluation reserves after the capitalisation for the bonus issue.

PART K - REQUIREMENTS RELATING TO EXCHANGE TRADED FUNDS**6.60 Requirements relating to exchange traded funds**

- (1) The provisions in this Chapter also apply to the listing of a new issue of units of an exchange traded fund, subject to such adaptations, where necessary.
- (2) An exchange traded fund must procure the SC's approval for issuance and listing of new units before submitting a listing application to the Exchange.
- (3) A management company must file with the Exchange an application for listing in respect of all new units to be issued in connection with the application, which units had not been previously approved by the Exchange.

[Cross reference: Practice Note 28]

PART L – REQUIREMENTS RELATING TO SPECIAL PURPOSE ACQUISITION COMPANIES**6.61 New issue of securities by SPAC**

- (1) A SPAC must not undertake any new issue of securities unless it is by way of rights issue of securities.
- (2) In undertaking a rights issue of securities, a SPAC must -
- (a) comply with Part E of this Chapter, where applicable; and
 - (b) place at least 90% of the gross proceeds raised in the rights issues in the same Trust Account held by the custodian in which the gross proceeds raised from the SPAC's initial public offering are kept, immediately upon receipt of the proceeds.

PART M – IMPLEMENTATION OF PROPOSALS**6.62 Implementation deadline**

- (1) Subject to subparagraph (2) below, a listed issuer must complete the implementation of a proposal relating to an issuance of securities ("**Issuance Proposal**") within 6 months from the date the listing application is approved by the Exchange.
- (2) For cases which involve court proceedings, a listed issuer has up to 12 months from the date the listing application is approved by the Exchange to complete the implementation of an Issuance Proposal.
- (3) Where the listed issuer has submitted a request for a review of the Exchange's decision, the time period to complete the implementation of an Issuance Proposal will commence from the date on which the decision on the review is conveyed to the listed issuer.
- (4) If the listed issuer fails to complete the implementation of an Issuance Proposal within the prescribed periods above, the Exchange's approvals given in regard to the Issuance Proposal will lapse.

6.63 Extension of implementation time

- (1) The Exchange may, upon a listed issuer's application, in exceptional cases grant an extension of time for a listed issuer to complete an Issuance Proposal. The listed issuer must apply for an extension through its Principal Adviser not later than 14 days before the Exchange's approval to the listing application expires. The listed issuer must fully justify its application.
- (2) All applications for an extension of time for completion of the Issuance Proposal under this paragraph must be accompanied by a confirmation letter by the directors of the listed issuer that, save as disclosed, there has been no material change or development in the circumstances and information relating to the Issuance Proposal.
- (3) Where the Exchange's approval is subject to certain conditions which must be fulfilled within a specified period of time, any application for an extension of time to fulfill the conditions must be fully justified and must be not later than 14 days before the expiry of the specified period.

6.64 Post-implementation obligations

- (1) A listed issuer and its Principal Adviser must inform the Exchange the dates of completion for all approved Issuance Proposal.
- (2) The listed issuer and its Principal Adviser must furnish the Exchange with a written confirmation of its compliance with terms and conditions of the Exchange's approval once the Issuance Proposal has been completed.
- (3) The listed issuer and its Principal Adviser must submit the actual figures once determined where an indicative issue price or number of securities to be issued are provided in the listing application for the Issuance Proposal.

[End of Chapter]

APPENDIX 6A**Part A****Contents of announcement in relation to a new issue of securities**

(paragraphs 6.07, 6.32, 6.48 and 6.52)

- (1) The number, type and par value (where applicable) of securities to be issued.
- (2) The ranking of the new issue of securities.
- (3) Whether listing will be sought for the new issue of securities.
- (4) The issue price of the new issue of securities, the basis of determining the issue price and justification for the pricing.
- (5) The basis of allotment, where applicable.
- (6) The persons to whom the new issue of securities will be allotted/issued.
- (7) The gross proceeds from the issue of securities and a detailed statement with regard to the utilisation of such proceeds, where applicable.
- (8) Where the proceeds from the new issue of securities are to be utilised for a new business to be acquired or undertaken, a description of the industry where the new business operates or will be operating.
- (9) The effect of the new issue of securities on -
 - (a) the issued and paid-up capital (to show effect for each proposal);
 - (b) the net assets per share based on the latest audited consolidated financial statements (to show effect for each proposal);
 - (c) the earnings per share of the group;
 - (d) the substantial shareholding structure (to show effect for each proposal);
 - (e) gearing, where applicable; and
 - (g) any existing convertible securities.
- (10) Where applicable, the minimum level of subscription and the basis of determining the minimum level of subscription.
- (11) The approvals required for the new issue and the estimated time frame for submission of the application to the relevant authorities.
- (12) The estimated time frame for completion of the new issue of securities.
- (13) Whether the directors, major shareholders or persons connected with them have any interest, direct or indirect, in the issue.
- (14) The purpose of the new issue of securities.
- (15) The justification for embarking on the new issuance of securities rather than other available options.

Appendix 6A
Contents of announcement for new issue of securities

- (16) In the case of a bonus issue or a two-call rights issue, -
- (a) the details of the reserves to be capitalised for the bonus issue or the second call of the two-call rights issue; ~~and~~
 - (b) a statement that the reserves required for capitalisation of the second call of the two-call rights issue or the bonus issue complies with paragraphs 6.19 and 6.30(1) of these Requirements; and
 - (c) where the bonus issue is to be made in stages over a period of time, relevant details of the same including -
 - (i) the extended implementation period;
 - (ii) the tentative books closing dates;
 - (iii) the effects of the bonus issue on reserves;
 - (iv) a statement that the listed issuer has adequate reserves to cover the entire bonus issue;
 - (v) a statement as to the potential price effects of the staggered implementation; and
 - (vi) the rationale/justification for the implementation of the bonus issue on a staggered basis.
- (17) In the case of issue and placement of securities in stages over a period of time, the relevant details of the same including the rationale/justification.
- (18) In the case of a share scheme for employees, the duration of the scheme, basis of determining the exercise price and eligibility.
- (19) Where the issuance of securities or proceeds are utilized for an acquisition of assets or interests and such acquisition falls within the ambit of Chapter 10 of these Requirements and announcement is required pursuant to Chapter 10, the relevant information on the transaction as required under Appendix 10A of these Requirements. ~~and~~
- (20) Where a mandate for issue of securities is sought, a statement whether such mandate is a renewal and the details of the previous mandate.

Part B**Additional contents of announcement in relation to an issue of debt securities**

(paragraph 6.48)

- (1) The interest rate and interest payment dates.
- (2) The issue and maturity dates.
- (3) The method of redemption.
- (4) Whether guaranteed or secured, and if so, details of such guarantee or security.
- (5) The rating of the issue. ~~and~~
- (6) A summary of other material terms of issue.

Appendix 6A
Contents of announcement for new issue of securities

Part C**Additional contents of announcement in relation to an issue of convertible securities**

(paragraph 6.52)

- (1) The conversion or exercise price and basis of determining the conversion or exercise price.;
- (2) The conversion or exercise period.;
- (3) The step-up or step-down pricing mechanism (if any), the amount of step-up or step-down and the time frames for the exercise or conversion price adjustment.
- (4) The number of new securities that will be issued upon full exercise or conversion.;
- (5) A summary of material terms of the issue.;
- (6) Where applicable, all provisions for changes in the terms of the convertible securities during the tenure of the securities.;
- (7) The use of future proceeds arising from the conversion or exercise.

[End of Appendix]

APPENDIX 6B**Part A****Contents of circular in relation to a new issue of securities**

(paragraphs 6.08(1) and 6.53(1))

- (1) A heading drawing attention to the importance of the circular and advising holders of securities who are in any doubt as to what action to take to consult appropriate independent ~~professional~~ advisers.;
- (2) A statement that Bursa Malaysia Securities Berhad takes no responsibility for the contents of the circular, makes no representation as to its accuracy or completeness and expressly disclaims any liability whatsoever for any loss howsoever arising from or in reliance upon the whole or any part of the contents of the circular. In relation to an Exempt Circular, a statement that Bursa Malaysia Securities Berhad has not perused the circular before its issuance.;
- (3) The purpose of the circular.;
- (4) The particulars, terms and conditions of the issue and date on which the new issue of securities was announced.;
- (5) The number, type and par value of the securities to be issued.;
- (6) The issue price of the new issue of securities, the basis of determining the issue price and justification for the pricing.;
- (7) The ranking of the new issue of securities and treatment of any fractions.;
- (8) Whether listing will be sought for the new issue of securities.;
- (9) The details of any other intended corporate exercise/scheme which have been announced but not yet completed before the printing of the circular and whether the new issue of securities is conditional or inter-conditional upon such and/or any other corporate exercise/scheme.;
- (10) The basis of allotment, where applicable.;
- (11) The persons to whom the new issue of securities will be allotted/issued.;
- (12) The purpose of the new issue of securities.;
- (13) The justifications for embarking on the new issuance of securities rather than other available options.;
- (14) A statement with regard to -
 - (a) the gross proceeds of the new issue of securities;
 - (b) the proposed utilisation of the gross proceeds specifying amongst others -
 - (i) if it is utilised to reduce borrowings, the amount of annual savings in interest payments and the total borrowings of the group as at the latest practicable date;

Appendix 6B
Contents of circular for new issue of securities

- (ii) if it is for expansion, relocation of factory or office premises, the details on the location of the factory or building, total cost of construction, built-up area and production capacity before and after the expansion or relocation (where relevant); or
 - (iii) if it is for investment purposes, the details of the investment, or if the investment has not been identified, a statement to that effect;
 - (c) the estimated expenses of the new issue of securities; and
 - (d) the time frame for full utilisation of the proceeds.†
- (15) Where the proceeds from the new issue of securities are to be utilised for -
- (a) the listed issuer's group of companies/corporations' existing business; or
 - (b) a new business to be acquired or undertaken,
a description and outlook of the industry where the listed issuer's group of companies/corporations operates or will be operating and the prospects of its business in light of the industry outlook.
- (16) The effects of the new issue of securities on -
- (a) the issued and paid-up capital (to show effect for each proposal);
 - (b) the net assets per share based on the latest audited consolidated financial statements (to show effect for each proposal);
 - (c) the earnings per share of the group;
 - (d) the substantial shareholding structure (to show effect for each proposal);
 - (e) gearing, where applicable; and
 - (f) any existing convertible securities.
- (17) A statement setting out all material commitments and contingent liabilities incurred or known to be incurred by the listed issuer.†
- (18) A statement as to whether the new issue of securities will be underwritten and the number and percentage of securities to be underwritten. Where the underwriting arrangements have been entered into, details of the underwriting arrangements, including -
- (a) the name(s) of the underwriter(s);
 - (b) the underwriting commission and the party that will bear the same; and
 - (c) any provisions which may permit the underwriter(s) to withdraw from obligations pursuant to the underwriting agreement and/or terminate the underwriting agreement.†
- (19) Where applicable, the minimum level of subscription and the basis of determining the minimum level of subscription. In the event the minimum level is not achieved, to state its impact on the proposal and alternative plans (if any).†

Appendix 6B
Contents of circular for new issue of securities

- (20) Where applicable, securities holders' undertakings stating the portion of the new issue of securities which the securities holders have given their written irrevocable undertaking to subscribe for their entitlement in full, including -
- (a) the names of securities holders;
 - (b) the number and percentage of the existing issued and paid-up capital held by them in the listed issuer; and
 - (c) the number and percentage of securities entitled to under the new issue of securities.†
- (21) Where securities holders have irrevocably undertaken to subscribe for the securities and if applicable, excess application -
- (a) a statement that the securities holders have confirmed that they have sufficient financial resources to take up the securities and such confirmation has been verified by an acceptable independent party such as the listed issuer's Principal Adviser; and
 - (b) a statement as to the consequences of the subscription for the securities on the listed issuer and its securities holders with regard to the Take-Overs and Mergers Code.†
- (22) The monthly highest and lowest market prices of the listed securities transacted for the 12 months preceding the date of the circular and the last transacted price immediately before the announcement of the new issue of securities and as at the latest practicable date before the printing of the circular.†
- (23) The approvals required for the new issue of securities and dates on which such approvals were obtained and conditions of the approvals, and the status of compliance.†
- (24) The estimated time frame for completion of the new issue of securities and in the case of rights issue or bonus issue, the tentative time table for the implementation of the proposal.†
- (25)
- (a) Whether the new issue of securities is to a director, major shareholder or person connected with a director or major shareholder.
 - (b) If the answer to (a) is in the affirmative, a statement that such person and also the director or major shareholder concerned, where the issue is to a person connected with a director or major shareholder, must abstain from voting in respect of their direct and/or indirect shareholdings.
 - (c) A statement that such interested director, major shareholder or both has/have undertaken that he/they will ensure that the persons connected with him/them will abstain from voting on the resolution approving the issue at the general meeting.
 - (d) In the case of an interested director, a statement that the interested director has abstained or will abstain from deliberating and voting on the relevant resolution at the board meeting.†
- (26) In the case of a bonus issue or a two-call rights issue -
- (a)
 - (i) the details of the reserves to be capitalised for the bonus issue or the second call of the two-call rights issue including the amount to be capitalised and the amount standing to the credit of such account;
 - (ii) a statement that the available reserves have been confirmed by the external auditors or reporting accountants pursuant to paragraph 6.30(3), if applicable;

Appendix 6B
Contents of circular for new issue of securities

- (b) a statement that the reserves required for capitalisation of the second call of the two-call rights issue or the bonus issue complies with paragraphs 6.19 and 6.30(1);
- (c) where the reserves to be capitalised arise from a revaluation of real estates, the name of the independent registered valuer, and the date and method of valuation. Incorporate the valuation certificate which must contain all particulars of and information on the property being valued and regard must be had to the SC's Asset Valuation Guidelines as to the contents of the valuation certificate. Make available for inspection the valuation report and valuation certificate;
- (d) where a ~~S~~second ~~O~~pinion ~~V~~valuation has been obtained, the figures for the original valuation and the ~~S~~second ~~O~~pinion ~~V~~valuation;
- (e) where the bonus issue is to be made in stages over a period of time, relevant details of the same including -
 - (i) the extended implementation period;
 - (ii) the tentative books closing dates;
 - (iii) the effects of the bonus issue on reserves;
 - (iv) a statement that the listed issuer has adequate reserves to cover the entire bonus issue;
 - (v) a statement drawing securities holders' attention to the staggered implementation of the bonus issue and the potential price effects of the staggered implementation; and
 - (vi) the rationale/justification for the implementation of the bonus issue on a staggered basis.;
- (27) In the case of issue and placement of securities in stages over a period of time, the relevant details of the same, including the rationale/justification.;
- (28) In the case of a share scheme for employees -
 - (a) the information set out in Appendix 6E;
 - (b) where applicable, the rationale for extending participation in the share scheme to non-executive directors;
 - (c) the performance targets, if any, that must be achieved before the options can be exercised or, if none, a negative statement to that effect; and
 - (d) the potential cost to the listed issuer arising from the grant of options under the share scheme for employees.;
- (29) In the case of issues of shares or convertible securities on a non-pro rata basis pursuant to paragraph 6.05, particulars on –
 - (a) the persons to whom the securities will be issued; and
 - (b) the amount of securities to be placed to each placee.;

Appendix 6B
Contents of circular for new issue of securities

- (30) Where the issuance of securities or proceeds are utilized for acquisition of assets/interests and such acquisition falls within the ambit of Chapter 10 and shareholder approval is required pursuant to Chapter 10, the relevant information on the transaction as required under Appendix 10B of these Requirements.†
- (31) A statement by the board of directors excluding interested directors stating whether the issue is in the best interest of the listed issuer and where a director disagrees with such statement, a statement by the director setting out the reasons and the factors taken into consideration in forming that opinion.†
- (32) Where voting is required, a recommendation together with the basis of such recommendation from the board of directors excluding interested directors as to the voting action that securities holders should take.†
- (33) In the case of a share scheme for employees, as an appendix, the bylaws of the scheme.†
- (34) An appendix containing the following information:
- (a) a responsibility statement by the directors that the circular has been seen and approved by the directors of the listed issuer and that they collectively and individually accept full responsibility for the accuracy of the information given and confirm that after making all reasonable enquiries to the best of their knowledge and belief there are no other facts the omission of which would make any statement in the circular misleading;
- (b) where a person is named in the circular as having advised the listed issuer or its directors, a statement -
- (i) that such adviser ~~or expert~~ has given and has not withdrawn its written consent to the inclusion of the adviser's ~~or expert's~~ name, letter or both (if applicable) in the form and context in which it is included; and
- (ii) by the adviser ~~or expert~~ as to whether a conflict of interests exists or is likely to exist in relation to its role as an adviser ~~or expert~~. If a conflict of interests exists or likely to exist in relation to its role as an adviser ~~or expert~~, to provide full disclosure of the nature and extent of the conflict of interests or potential conflict of interests, the parties to the conflict; and measures taken for resolving, eliminating, or mitigating the situations of conflict of interests.†
- For this purposes, "conflict of interests" means circumstances or relationships which affect or may affect the ability of the adviser to act independently and objectively or where the adviser has an interest in the outcome of the proposal which interferes or is likely to interfere with its independence and objectivity;
- (c) a statement of all material litigation, claims or arbitration involving the listed issuer and/or any of its subsidiaries, including those pending or threatened against such ~~companies~~corporations. The following particulars must be disclosed:
- (i) the background;
- (ii) the date of the suit;
- (iii) the names of the plaintiff(s) and defendant(s);
- (iv) the estimate of the maximum exposure to liabilities;
- (v) directors'/solicitors' opinion of the outcome; and

Appendix 6B
Contents of circular for new issue of securities

- (vi) the status;
- (d) a statement that from the date of the circular until the date of the general meeting the following documents (or copies of the documents) may be inspected at the registered office of the listed issuer:
 - (i) the memorandum and articles of association;
 - (ii) the audited financial statements of the listed issuer, group or both for the past 2 financial years and the latest unaudited results since the last audited financial statements;
 - (iii) all reports, letters or other documents, balance sheets, valuations and statements by any expert, any part of which is extracted or referred to in the circular;
 - (iv) the letters of consent referred to in subparagraph (b) above;
 - (v) the relevant cause papers in respect of the material litigation referred to in subparagraph (c) above;
 - (vi) the trust deed and/or deed poll (where applicable);
 - (vii) the profit estimate and/or forecast together with the auditors' letter ~~thereon~~ (if provided);
 - (viii) the pro forma consolidated balance sheet together with the auditors' letter ~~thereon~~ (if provided); and
 - (ix) bylaws of the scheme, in the case of a share scheme for employees, ~~and~~
- (35) Any other information which the securities holders and their Principal Advisers would reasonably expect to find in a circular of that nature for the purpose of making an informed decision.

Part B**Additional contents of circular in relation to convertible securities**

(paragraph 6.53(1))

- (1) The maximum number of the underlying securities which would be issued on the exercise of the convertible securities. ~~;~~
- (2) The ranking of the securities arising from the exercise or conversion. ~~;~~
- (3) Whether listing will be sought for the securities that will be issued upon exercise or conversion. ~~;~~
- (4) The period during which the convertible securities may be exercised and the date when this right commences and expires. ~~;~~
- (5) The amount payable on the exercise of the convertible securities and the basis of determining the exercise or conversion price. ~~;~~
- (6) The step-up or step-down pricing mechanism (if any), the amount of step-up or step-down and the time frames for the adjustment of the exercise or conversion price. ~~;~~
- (7) The rights of the holders on the liquidation of the listed issuer. ~~;~~

Appendix 6B
Contents of circular for new issue of securities

- (8) The arrangement for the adjustment in the subscription or purchase price and in the number of convertible securities in the event of alteration to the share capital of the listed issuer.;
- (9) The rights (if any) of the holders to participate in any distributions and/or offers of further securities made by the listed issuer.;
- (10) Where the convertible securities have debt features -
- (a) the interest rate and interest payment date(s);
 - (b) the method of redemption;
 - (c) whether guaranteed or secured; and if so, details of such guarantee or security; and
 - (d) the rating of the issue.;
- (11) A summary of the material terms of the convertible securities.;
- (12) Where applicable, all provisions for changes in the terms of the convertible securities during the tenure of the securities.;
- (13) The proposed utilisation of proceeds arising from the exercise or conversion of convertible securities.

[End of Appendix]

APPENDIX 6C

Timeline for a rights issue
(paragraph 6.23(2))

	Timeline for a rights issue	Time Limits	Market days*
1	Books closing date (B) to determine persons entitled to participate in the rights issue		B
2	Public release of the abridged prospectus in respect of the rights issue	1 market day before trading of rights commences	B
3	Trading of rights commences	1 market day after books closing date	B+1
4	Listed issuer issues - (a) the Provisional Allotment Letter (PAL) to the Depository and where applicable, entitled persons of securities which have been exempted from deposit with the Depository; and (b) the following to the entitled persons of deposited securities: (i) the notices of provisional allotment; and (ii) the rights subscription forms.	Within 2 market days after books closing date	B+2
5	Cessation of trading of rights	5 market days before the last date of acceptance	B+6
6	Closing date for receipt of applications for and acceptance of the rights	At least 11 market days after the books closing date	B+11

Note:

* The number of market days from the books closing date (B) is stated based on minimum or maximum periods allowed, as the case may be.

[End of Appendix]

APPENDIX 6D

Undertaking by a valuer of a listed issuer

(paragraphs 6.31 and 10.04)

To

Bursa Malaysia Securities Berhad
Exchange Square
Bukit Kewangan
50200 Kuala Lumpur

Compliance with Main Market Listing Requirements

In consideration of Bursa Malaysia Securities Berhad ("**Bursa Securities**") accepting the valuation report and such other documents prepared by us as required under Bursa Securities Main Market Listing Requirements ("**Listing Requirements**"), WE[name & company no. of the valuer] having a #registered address/place of business at..... UNDERTAKE AND AGREE to comply with the Listing Requirements, including any amendment as may be made from time to time and insofar as the same is applicable to us as a valuer.

**This Undertaking is deemed to have been made in Malaysia and the construction, validity and performance of this Undertaking are governed in all respects by the laws of Malaysia and WE irrevocably submit to the jurisdiction of the Malaysian Courts.

The above Undertaking has been signed by us/me as..... [title/designation] of[name of valuer] pursuant to authority granted to us/me by resolution of the board of directors of the valuer on.....

Yours faithfully,

.....
Name:
Designation:
Date:

Delete as appropriate

** Applicable to a foreign valuer only.

[End of Appendix]

Appendix 6E
Contents of bylaws of a share scheme for employees

APPENDIX 6E**Contents of bylaws of a share scheme for employees**

(paragraphs 6.42 and 6.44)

- (1) The persons to whom shares may be issued under the scheme (“**participants**”) and the basis of determining the eligibility of participants.
- (2) The maximum number of options to be offered under the scheme.
- (3) The maximum entitlement for each class or category of participant (where applicable) and the maximum entitlement for any one participant (where applicable).
- (4) The amount payable on application or acceptance and the basis for determining the subscription or sale, or option price, the period in or after which payments or calls, or loans to provide the same, may be paid or called upon.
- (5) The time limit for the scheme.
- (6) The minimum period, if any, for which an option must be held before it can be exercised.
- (7) The voting, dividend, transfer and other rights, including those arising on a liquidation of the listed issuer or the subsidiary, as the case may be, attaching to the shares.
- (8) Formulas for adjustments to the subscription or option price or the number of shares (excluding options already exercised) under the scheme, in the event of a capitalisation issue, rights issue, bonus issue, consolidation or subdivision of shares, capital reduction and/or any other variation of capital;
- (9) A provision that the matters relating to ~~items~~ paragraphs (1) to (8) above cannot be altered to the advantage of participants without prior shareholder approval.

[End of Appendix]

APPENDIX 6F**Contents of a trust deed/deed poll**
(paragraph 6.54(2))

- (1) The step-up or step-down pricing mechanism (if any) which must be on a fixed basis, i.e. stated in absolute amounts or terms and must not be made conditional upon the occurrence of certain events.
- (2) The amount of step-up or step-down and the time frames for the exercise or conversion price adjustment.
- (3) Provisions for changes in the terms of convertible securities during the tenure of the securities.

[End of Appendix]

CHAPTER 7 ARTICLES OF ASSOCIATION**PART A - GENERAL****7.01 Introduction**

- (1) Parts B to N of this Chapter set out the provisions which an applicant or a listed corporation must ensure are contained in its articles of association.
- (2) Part O of this Chapter sets out the additional provisions which a closed-end fund must ensure are contained in its articles of association.
- (3) Part P of this Chapter sets out the additional provisions which a special purpose acquisition company must ensure are contained in its articles of association.

PART B - DEFINITIONS**7.02 Definitions**

For the purpose of this Chapter, unless the context otherwise requires, “**company**” means a company which is seeking a listing on the Official List or a listed corporation.

PART C - CAPITAL**7.03 Issue of shares to directors**

No director shall participate in a share scheme for employees unless shareholders in general meeting have approved the specific allotment to be made to such director.

7.04 Rights of other classes of shares

The rights attaching to shares of a class other than ordinary shares shall be expressed.

7.05 Power to issue further preference shares

Whether the company has power to issue further preference capital ranking equally with, or in priority to, preference shares already issued.

7.06 Rights of preference shareholders

- (1) The holder of a preference share must be entitled to a right to vote in each of the following circumstances:
 - (a) when the dividend or part of the dividend on the share is in arrears for more than 6 months;
 - (b) on a proposal to reduce the company's share capital;
 - (c) on a proposal for the disposal of the whole of the company's property, business and undertaking;
 - (d) on a proposal that affects rights attached to the share;

-
- (e) on a proposal to wind up the company; and
 - (f) during the winding-up of the company.
- (2) A holder of a preference share must be entitled to the same rights as a holder of an ordinary share in relation to receiving notices, reports and audited financial statements, and attending meetings.

7.07 Capital paid on shares in advance of calls

Capital paid on shares in advance of calls shall not, whilst carrying interest, confer a right to participate in profits.

7.08 Issue of new shares to members

Subject to any direction to the contrary that may be given by the company in general meeting, all new shares or other convertible securities shall, before issue, be offered to such persons as at the date of the offer are entitled to receive notices from the company of general meetings in proportion as nearly as the circumstances admit, to the amount of the existing shares or securities to which they are entitled. The offer shall be made by notice specifying the number of shares or securities offered, and limiting a time within which the offer, if not accepted, will be deemed to be declined, and, after the expiration of that time, or on the receipt of an intimation from the person to whom the offer is made that he declines to accept the shares or securities offered, the directors may dispose of those shares or securities in such manner as they think most beneficial to the company. The directors may likewise also dispose of any new share or security which (by reason of the ratio which the new shares or securities bear to shares or securities held by persons entitled to an offer of new shares or securities) cannot, in the opinion of the directors, be conveniently offered under this article.

PART D - FORFEITURE AND LIEN

7.09 Company's lien on shares and dividends

The company's lien on shares and dividends from time to time declared in respect of such shares, shall be restricted to unpaid calls and instalments upon the specific shares in respect of which such moneys are due and unpaid, and to such amounts as the company may be called upon by law to pay and has paid in respect of the shares of the member or deceased member.

7.10 Sale of shares forfeited

If any share is forfeited and sold, any residue after the satisfaction of the unpaid calls and accrued interest and expenses, shall be paid to the person whose shares have been forfeited, or his executors, administrators or assignees or as he directs.

PART E - TRANSFER AND TRANSMISSION

7.11 Transfers of securities

The transfer of any listed security or class of listed security of the company, shall be by way of book entry by the Depository in accordance with the Rules of the Depository and, notwithstanding sections 103 and 104 of the Companies Act 1965, but subject to subsection 107C(2) of the Companies Act 1965 and any exemption that may be made from compliance with subsection 107C(1) of the Companies Act 1965, the company shall be precluded from registering and effecting any transfer of the listed securities.

7.12 Transmission of securities

Where -

- (a) the securities of a company are listed on another stock exchange; and
- (b) such company is exempted from compliance with section 14 of the Securities Industry (Central Depositories) Act 1991 or section 29 of the Securities Industry (Central Depositories) (Amendment) Act 1998, as the case may be, under the Rules of the Depository in respect of such securities,

such company shall, upon request of a securities holder, permit a transmission of securities held by such securities holder from the register of holders maintained by the registrar of the company in the jurisdiction of the other stock exchange, to the register of holders maintained by the registrar of the company in Malaysia and vice versa provided that there shall be no change in the ownership of such securities.

PART F - MODIFICATION OF RIGHTS**7.13 Modification of rights**

The repayment of preference capital other than redeemable preference capital or any other alteration of preference shareholders' rights, may only be made pursuant to a special resolution of the preference shareholders concerned, provided always that where the necessary majority for such a special resolution is not obtained at the meeting, consent in writing, if obtained from the holders of three-fourths of the preference capital concerned within 2 months of the meeting, shall be as valid and effectual as a special resolution carried at the meeting.

PART G - BORROWING**7.14 Scope of directors' borrowing powers**

The scope of the borrowing powers of the board of directors shall be expressed.

PART H - MEETINGS**7.15 Notices of meetings**

The notices convening meetings shall specify the place, day and hour of the meeting, and shall be given to all shareholders at least 14 days before the meeting or at least 21 days before the meeting where any special resolution is to be proposed or where it is an annual general meeting. Any notice of a meeting called to consider special business shall be accompanied by a statement regarding the effect of any proposed resolution in respect of such special business. At least 14 days' notice or 21 days' notice in the case where any special resolution is proposed or where it is the annual general meeting, of every such meeting must be given by advertisement in at least 1 nationally circulated Bahasa Malaysia or English daily newspaper and in writing to each stock exchange upon which the company is listed.

7.16 Record of Depositors

- (1) The company shall request the Depository in accordance with the Rules of the Depository, to issue a Record of Depositors to whom notices of general meetings shall be given by the company.

-
- (2) The company shall also request the Depository in accordance with the Rules of the Depository, to issue a Record of Depositors, as at the latest date which is reasonably practicable which shall in any event be not less than 3 market days before the general meeting (“**General Meeting Record of Depositors**”).
- (3) Subject to the Securities Industry (Central Depositories) (Foreign Ownership) Regulations 1996 (where applicable), a depositor shall not be regarded as a member entitled to attend any general meeting and to speak and vote thereat unless his name appears in the General Meeting Record of Depositors.

PART I - VOTING AND PROXIES

7.17 Voting rights of members

Subject to paragraph 7.16 above, a member of the company shall be entitled to be present and to vote at any general meeting in respect of any share or shares upon which all calls due to the company have been paid.

7.18 Voting rights on a show of hands

On a resolution to be decided on a show of hands, a holder of ordinary shares or preference shares who is personally present and entitled to vote shall be entitled to 1 vote.

7.19 Voting right of proxy

A proxy shall be entitled to vote on a show of hands on any question at any general meeting.

7.20 Voting rights of shares of different monetary denominations

Where the capital of a company consists of shares of different monetary denominations, voting rights shall be prescribed in such a manner that a unit of capital in each class, when reduced to a common denominator, shall carry the same voting power when such right is exercisable.

7.21 Appointment of at least one proxy

Where a member of the company is an authorised nominee as defined under the Securities Industry (Central Depositories) Act 1991, it may appoint at least one proxy in respect of each securities account it holds with ordinary shares of the company standing to the credit of the said securities account.

PART J - DIRECTORS

7.22 Directors' power to fill casual vacancies and to appoint additional directors

Where provision is made for the directors to appoint a person as a director either to fill a casual vacancy, or as an addition to the board, any director so appointed shall hold office only until the next annual general meeting of the company, and shall then be eligible for re-election.

7.23 Remuneration of directors

Fees payable to non-executive directors shall be by a fixed sum, and not by a commission on or percentage of profits or turnover. Salaries payable to executive directors may not include a commission on or percentage of turnover.

7.24 Increase in directors' remuneration

Fees payable to directors shall not be increased except pursuant to a resolution passed at a general meeting, where notice of the proposed increase has been given in the notice convening the meeting.

7.25 Directors' interest in contracts

A director shall not vote in regard to any contract or proposed contract or arrangement in which he has, directly or indirectly, an interest.

7.26 Election of directors

- (1) An election of directors shall take place each year.
- (2) All directors shall retire from office once at least in each 3 years, but shall be eligible for re-election.

7.27 Vacation of office of director

The office of a director shall become vacant if the director becomes of unsound mind or bankrupt during his term of office.

7.28 Notice of intention to appoint director

No person, not being a retiring director, shall be eligible for election to the office of director at any general meeting unless a member intending to propose him for election has, at least 11 clear days before the meeting, left at the registered office of the company a notice in writing duly signed by the nominee, giving his consent to the nomination and signifying his candidature for the office, or the intention of such member to propose him for election, provided that in the case of a person recommended by the directors for election, 9 clear days' notice only shall be necessary, and notice of each and every candidature for election to the board of directors shall be served on the registered holders of shares at least 7 days before the meeting at which the election is to take place.

7.29 Power of managing director

A managing director shall be subject to the control of the board of directors.

7.30 Proceedings in case of vacancies

The remaining directors may continue to act notwithstanding any vacancy in their body, but if and so long as their number is reduced below the minimum number fixed by or pursuant to the articles of the company, the remaining directors may, except in an emergency, act only for the purpose of increasing the number of directors to such minimum number, or to summon a general meeting of the company.

7.31 Appointment of alternate director

A director may appoint a person approved by a majority of his co-directors to act as his alternate, provided that any fee paid by the company to the alternate shall be deducted from that director's remuneration.

7.32 Chairman's casting vote

Where 2 directors form a quorum, the chairman of a meeting at which only such a quorum is present, or at which only 2 directors are competent to vote on the question at issue shall not have a casting vote.

PART K – ACCOUNTS**7.33 Presentation of accounts**

The interval between the close of a financial year of the company and the issue of the annual audited financial statements, the directors' and auditors' reports shall not exceed 4 months.

PART L - WINDING-UP**7.34 Distribution of assets in specie**

The basis on which shareholders will participate in a distribution of assets on a winding-up shall be expressed.

7.35 Liquidator's commission

On the voluntary liquidation of the company, no commission or fee shall be paid to a liquidator unless it shall have been approved by shareholders. The amount of such payment shall be notified to all shareholders at least 7 days before the meeting at which the commission or fee is to be considered.

PART M - EFFECT OF THESE REQUIREMENTS**7.36 Effect of the Listing Requirements**

- (1) Notwithstanding anything contained in these articles, if the Listing Requirements prohibit an act being done, the act shall not be done.
- (2) Nothing contained in these articles prevents an act being done that the Listing Requirements require to be done.
- (3) If the Listing Requirements require an act to be done or not to be done, authority is given for that act to be done or not to be done (as the case may be).
- (4) If the Listing Requirements require these articles to contain a provision and they do not contain such a provision, these articles are deemed to contain that provision.
- (5) If the Listing Requirements require these articles not to contain a provision and they contain such a provision, these articles are deemed not to contain that provision.
- (6) If any provision of these articles is or becomes inconsistent with the Listing Requirements, these articles are deemed not to contain that provision to the extent of the inconsistency.
- (7) For the purpose of this article, unless the context otherwise requires, "Listing Requirements" means Bursa Malaysia Securities Berhad Main Market Listing Requirements including any amendment to the Listing Requirements that may be made from time to time.

PART N - AMENDMENTS TO THIS CHAPTER**7.37 Amendments to this Chapter**

Where any amendment is made by the Exchange to the provisions of this Chapter, a company must make corresponding amendment(s) to its articles of association to reflect the said amendment unless its articles include the provision in paragraph 7.36 or its equivalent.

PART O - CLOSED-END FUNDS**7.38 Amendment to investment policies and objectives**

Any amendment to a closed-end fund's investment policies and objectives shall be approved by the shareholders of the closed-end fund by way of a special resolution.

7.39 Management control

A closed-end fund shall not, either on its own or in conjunction with any person, take legal or effective management control of its underlying investments.

7.40 Maximum holdings

No shareholder of a closed-end fund shall hold more than 20% of the total issued and paid-up capital of a closed-end fund.

7.41 Prohibition against conduct of other business

A closed-end fund shall not conduct any other business other than that of a closed-end fund.

PART P – SPECIAL PURPOSE ACQUISITION COMPANIES**7.42 ~~Securities holders approval to complete~~Completion of a qualifying acquisition**

(1) A SPAC shall not proceed to complete a qualifying acquisition unless –

~~(a) the SPAC convenes a general meeting to obtain the approval of its holders of the voting securities;~~

~~(ba)~~ where the qualifying acquisition comprises more than one acquisition, the sale and purchase agreements relating to each of the acquisitions are inter-conditional and shall complete simultaneously within 36 months from the date of listing of the SPAC on the Exchange; and

~~(eb)~~ the respective resolution on each qualifying acquisition is approved by a majority in number of the holders of voting securities representing at least 75% of the total value of securities held by all holders of voting securities present and voting either in person or by proxy at a general meeting duly convened for that purpose.

(2) A member of the management team and persons connected with them shall not vote on a resolution approving a qualifying acquisition.

7.43 Rights of voting securities holders

(1) Holders of voting securities (other than the members of the management team and persons connected with them) who vote against a qualifying acquisition at a meeting convened to consider the qualifying acquisition shall be entitled to receive, in exchange for their securities, a sum equivalent to a pro rata portion of the amount then held in the Trust Account (net of any taxes payable and expenses related to the facilitation of the exchange), provided that such qualifying acquisition is approved and the qualifying acquisition is completed not later than 36 months from the date of its admission to the Exchange.

-
- (2) Holders of voting securities who elect to exchange their securities pursuant to subparagraph (1) above shall be paid immediately upon completion of the qualifying acquisition. Securities which are tendered by these holders in exchange for cash shall be cancelled.
- (3) If the qualifying acquisition is not completed within the timeframe set out in subparagraph (1) above, each holder of voting securities shall be entitled to receive a pro rata share of the aggregate amount then on deposit in the Trust Account (net of any taxes payable and direct expenses related to the liquidation distribution).

7.44 Liquidation of a special purpose acquisition company

- (1) A SPAC shall be dissolved, wound up and liquidated in accordance with the applicable laws and regulations in the following circumstances:
- (a) if the SPAC fails to complete a qualifying acquisition within 36 months from the date of its admission to the Exchange; or
 - (b) if before the SPAC completes a qualifying acquisition, the SPAC is delisted by the Exchange.
- (2) Upon liquidation, the amount then held in the Trust Account (net of any taxes payable and expenses related to the liquidation distribution), shall be distributed to the respective holders of voting securities on a pro rata basis, as soon as practicable, as permitted by the relevant laws and regulations. Any interest earned from the Permitted Investment accruing in the Trust Account shall form part of the liquidation distribution.
- (3) A member of the management team and persons connected with them shall not participate in the liquidation distribution except in respect of securities purchased by them after the date of admission of the SPAC on the Exchange.

[End of Chapter]

CHAPTER 8 CONTINUING LISTING OBLIGATIONS**PART A - GENERAL****8.01 Introduction**

This Chapter sets out the continuing listing obligations that must be complied with, amongst others, by a listed issuer, its directors or advisers in addition to other continuing listing obligations which have been set out in other Chapters of these Requirements.

PART B –CONTINUING LISTING CRITERIA**8.02 Compliance with shareholding spread requirement**

- (1) A listed issuer must ensure that at least 25% of its total listed shares (excluding treasury shares) are in the hands of public shareholders. The Exchange may accept a percentage lower than 25% of the total number of listed shares (excluding treasury shares) if it is satisfied that such lower percentage is sufficient for a liquid market in such shares.
- (2) For listed issuers which have shares listed on other stock exchange(s), shares listed on the other stock exchange(s) are included for the purpose of computing the percentage of shareholding spread referred to in subparagraph (1) above.
- (3) A listed issuer must immediately announce to the Exchange if it becomes aware that it does not comply with the required shareholding spread referred to in subparagraph (1) above.
- (4) A listed issuer which fails to maintain the required shareholding spread referred to in subparagraph (1) above may request for an extension of time to rectify the situation in the manner as may be prescribed by the Exchange.

[Cross reference: Practice Note 19]

8.03 Cash Companies

- (1) A listed issuer whose assets on a consolidated basis, consist of 70% or more of cash or short term investments, or a combination of both ("**Cash Criterion**") must immediately notify the Exchange of its condition in writing. The Exchange will determine whether such listed issuer should be considered a Cash Company. A listed issuer considered as a Cash Company by the Exchange will be notified by the Exchange.
- (2) A Cash Company must comply with such requirements as may be prescribed by the Exchange, failing which the Exchange may suspend the trading of listed securities of such listed issuer or de-list it, or both.
- (3) For the purposes of subparagraph (1) above -
 - (a) a listed issuer must, as a minimum requirement, make a determination as to whether it triggers the Cash Criterion when it disposes its assets or business on a group basis or prepares its financial statements or accounts; and
 - (b) "**short term investments**" means investments which are by their nature readily realisable and intended to be held for 12 months or less including interests (equity or otherwise) in ~~companies~~corporations.

- (4) A Cash Company must place at least 90% of its cash and short-dated securities (including existing cash balance and the consideration arising from the disposal undertaken by the Cash Company) in an account opened with a financial institution licensed by Bank Negara Malaysia and operated by a custodian. Any interest generated by the monies held in the account must accrue to the account. For the purpose of this subparagraph (4), "custodian" means any of the following who is independent of the Cash Company:
- (a) a trust company registered under the Trust Companies Act 1949 or incorporated pursuant to the Public Trust Corporation Act 1995 and is in the List of Registered Trustees in relation to Unit Trust Funds issued by the SC; or
 - (b) a licensed bank or merchant bank as defined in the Banking and Financial Institutions Act 1989.

The Cash Company must ensure that the amount placed in the above account is not withdrawn, except for the following purposes:

- (i) implementing a proposal to acquire a new core business approved by the SC.
 - (ii) pro-rata distributions to shareholders pursuant to subparagraph (9) below.
- (5) A Cash Company must comply with the following additional requirements:
- (a) regularise its condition in the following manner:
 - (i) submit a proposal to acquire a new core business to the SC for its approval within 12 months from the date it receives the notice referred to in subparagraph (1) above; and
 - (ii) implement its proposal within the timeframe prescribed by the SC-;
 - (b) provide such information as may be prescribed by the Exchange from time to time for public release; and
 - (c) do such other acts or things as may be required by the Exchange.
- (6) The Exchange may suspend the trading of the Cash Company's listed securities if it fails to comply with any part of its obligations in subparagraph (5)(a) above or if its proposal is rejected by the SC and the Exchange may de-list such Cash Company.
- (7) Subparagraphs (1) and (2) above are not applicable to the following listed issuers:
- (a) listed issuers whose activities are regulated by any written law relating to banking, finance ~~companies-corporations~~ or insurance and are subject to supervision by Bank Negara Malaysia;
 - (b) Participating Organisations;
 - (c) closed-end funds;
 - (d) real estate investment trusts;
 - (e) exchange traded funds;
 - (f) infrastructure project corporations which have not completed their infrastructure project(s);
 - (g) special purpose acquisition companies; and

-
- (h) such other category of listed issuers as may be prescribed by the Exchange.
- (8) For a Cash Company to be no longer considered a Cash Company, the Cash Company must –
- (a) complete the implementation of its proposal; and
 - (b) submit an application to the Exchange to demonstrate that it is no longer a Cash Company, together with all the necessary documentary evidence.

The fact that a Cash Company has ceased to trigger the Cash Criterion before it completes the implementation of its proposal, would not entitle it to be no longer considered as a Cash Company for the purpose of this subparagraph.

- (9) If the Cash Company fails to comply with any part of its obligations in subparagraph (5)(a) above, it must ensure that all moneys deposited, together with interests earned with the financial institution licensed by Bank Negara Malaysia and operated by a custodian under subparagraph (4) above are distributed to its shareholders on a pro-rata basis as soon as practicable.

[Cross reference: Practice Notes [16](#); ~~Practice Note~~ and [29](#)]

8.04 Financial condition and level of operations

- (1) The financial condition and level of operations of a listed issuer on a consolidated basis must, in the opinion of the Exchange, warrant continued trading or listing on the Official List.
- (2) The Exchange may prescribe certain criteria in relation to the financial condition and level of operations of a listed issuer ("**Prescribed Criteria**"). When a listed issuer triggers any of the Prescribed Criteria ("**PN17 Company**"), it must comply with such requirements as may be prescribed by the Exchange, failing which the Exchange may suspend the trading of listed securities of such listed issuer or de-list it, or both.
- (3) A PN17 Company must –
- (a) regularise its condition in the following manner:
 - (i) within 12 months from the date it announces that it is a PN17 Company:
 - (aa) submit a regularisation plan to the SC if the plan will result in a significant change in the business direction or policy of the PN17 Company; or
 - (bb) submit a regularisation plan to the Exchange if the plan will not result in a significant change in the business direction or policy of the PN17 Company, and obtain the Exchange's approval to implement the plan; and
 - (ii) implement the plan within the timeframe stipulated by the SC or the Exchange, as the case may be;
 - (b) provide such information as may be prescribed by the Exchange from time to time for public release; and
 - (c) do such other acts or things as may be required by the Exchange.

-
- (4) Where the Exchange approves the regularisation plan of a PN17 Company, such approval may be unconditional or subject to such conditions, as it deems fit. If the regularisation plan is rejected by the Exchange, the PN17 Company may appeal against the decision of the Exchange within 1 month from the date of its rejection.
- (5) If a PN17 Company fails to comply with any part of its obligations under subparagraph (3)(a) above, the Exchange shall –
- (a) suspend the trading of the PN17 Company's listed securities on the next market day after 5 market days from the date of notification of suspension by the Exchange; and
 - (b) de-list such PN17 Company subject to the latter's right to appeal against the de-listing under subparagraph (6) below.
- (6) A PN17 Company which intends to appeal against a de-listing under this paragraph 8.04 must submit its appeal to the Exchange within 5 market days from the date of notification of de-listing by the Exchange.
- (7) Where there is an appeal submitted to the Exchange, the Exchange shall stay the de-listing of the PN17 Company concerned pending consideration of the appeal. However, the Exchange shall suspend the trading of the PN17 Company's listed securities on the next market day after 5 market days from the date of notification of suspension by the Exchange even though the decision of the appeal is still pending.
- (8) For a PN17 Company to be no longer considered a PN17 Company, the PN17 Company must –
- (a) complete the implementation of its regularisation plan; and
 - (b) submit an application to the Exchange to demonstrate that it is no longer a PN17 Company, together with all the necessary documentary evidence.
- The fact that a PN17 Company has ceased to trigger the Prescribed Criteria before it completes the implementation of its regularisation plan, would not entitle it to be no longer considered as a PN17 Company for the purpose of this subparagraph.
- (9) If a PN17 Company triggers any one or more of the Prescribed Criteria within 3 years after it is no longer considered a PN17 Company, such PN17 Company must undertake a regularisation plan which will result in a significant change in its business direction or policy and submit the plan to the SC for approval. The PN17 Company must also comply with all requirements set out in this paragraph 8.04.

[Cross reference: [Practice Notes 17](#); [Practice Note and 29](#)]

PART C - CERTIFICATES, TRANSFERS AND TRANSMISSIONS

8.05 Proxy forms

A listed issuer must design its proxy forms in a manner which will allow a securities holder of the listed issuer appointing a proxy to indicate how he would like his proxy to vote in relation to each resolution.

8.06 Audit for transfers and issue of certificates

A listed issuer must provide the Exchange, upon request, with an external auditor's certificate to the effect that the issue of securities is in accordance with the requirements set out in paragraphs 6.28, 6.45, 6.58 and 8.15, where applicable

8.07 Number of securities

A listed issuer must ensure that the number of securities represented by a certificate is clearly shown in words and figures on the face of the certificate or in such other manner as may be approved by the Exchange.

8.08 Paper quality and watermark

A listed issuer must ensure that the certificates are designed so that forgery and/or alterations are readily detectable. A listed issuer must entrust the printing of securities certificates to recognised security printers and ensure that the paper for the securities is first class bond or banknote paper containing a watermark of the printer or **listed** issuer, and such other additional security features as the Exchange may determine from time to time.

8.09 Size of certificates

A listed issuer must ensure that the certificates measure 8"X10" (including perforations) or such other size as may be determined by the Exchange from time to time.

8.10 Submission of semi-annual returns

A listed issuer must submit to the Exchange returns as at 30 June and 31 December of each calendar year within 2 months from the said dates respectively, which include such information as may be prescribed by the Exchange from time to time by way of an electronic template provided by the Exchange.

8.11 Change in classification

- (1) Where there are circumstances to signify that a change in the classification of a listed issuer in a specific sector has taken place, the listed issuer must propose to the Exchange of the change in classification in such manner as may be prescribed by the Exchange. The proposed change in classification is subject to the approval of the Exchange. The Exchange may in its absolute discretion either maintain the classification or classify the listed issuer into such other sector as it deems fit.
- (2) Notwithstanding the absence of any notification from the listed issuer, the Exchange may, where the circumstances warrant the same, change the classification of a listed issuer to a sector which, in the opinion of the Exchange, is more appropriate for the listed issuer.

[Cross-reference: Practice Note 7]

PART D - SPONSORSHIP OF DEPOSITORY RECEIPTS

8.12 Sponsorship of depository receipts

A listed issuer must not enter into an agreement with a depository bank to sponsor **a** depository receipt programme unless the following terms are incorporated in the said agreement:

- (a) the total number of custodians holding the listed issuer's securities for which the receipts are issued ("**underlying securities**") must not be more than 5;
- (b) the total number of underlying securities at any time must not be more than 5% of the total issued and paid-up capital of the listed issuer;

- (c) the depository bank must provide to the listed issuer, information in respect of the depository receipt that will enable the listed issuer to comply with these Requirements; and
- (d) where there is more than one custodian bank appointed, the depository bank must fix a limit for the number of securities to be held by each custodian so that the total number of securities held by all the custodians does not exceed the limit referred to in subparagraph (b) above.

8.13 Status report on depository receipt

- (1) A listed issuer which has entered into an agreement to sponsor a depository receipt programme must provide to the Exchange, for its information, every quarter of a calendar year, the following ("**status report**"):
 - (a) the number and names of the custodians holding the securities for which the depository receipts are issued; and
 - (b) the total number and percentage of the securities for which the depository receipts are issued against its issued and paid-up capital and a breakdown of the same in respect of the securities held by each custodian.
- (2) Where the status report shows that the percentage of the securities for which the depository receipts are issued against its issued and paid-up capital exceeds the limit referred to in paragraph 8.12(b) above, the Exchange will forward such report to the Depository, for its further action.

PART E - OFFER FOR SALE

8.14 Renounceable offer for sale

A listed issuer ~~and~~/or an offeror, or both, in a renounceable offer for sale of securities listed or proposed to be listed on the Official List must comply with the requirements of paragraphs 6.22, 6.23, 6.24, 6.26, 6.27 and 6.28 as if its offer for sale were the rights issue mentioned in those paragraphs.

8.15 Allotment of securities and despatch of notices of allotment in respect of an offer for sale

In respect of an offer for sale to the existing holders of listed securities or the public, of securities listed or proposed to be listed on the Official List as the case may be, within 15 market days of the final applications date or such other period as may be prescribed by the Exchange, a listed issuer, offeror, or both, must -

- (a) cause the securities to be credited into the securities accounts of the successful applicants or issue and/or allot ~~and/or issue~~ securities, as the case may be;
- (b) despatch notices of allotment to the successful applicants; and
- (c) apply for the quotation of such securities (where applicable).

PART F - DIRECTORS**8.16 Director's undertaking**

A listed issuer must ensure that every director of the listed issuer gives the Exchange not later than 14 days after his appointment, an undertaking in the form as may be prescribed by the Exchange.

[Cross reference: Annexure PN21-C and PN21-D of Practice Note 21; Annexures PN23-C, PN23-D, PN23-G and PN23-H of Practice Note 23]

PART G - SHARE SCHEMES FOR EMPLOYEES**8.17 Allocation under a share scheme for employees**

- (1) A listed issuer must disclose to employees the criteria for allocation of options pursuant to a share scheme for employees.
- (2) A listed issuer must ensure that allocation of options pursuant to a scheme is verified by the audit committee, as being in compliance with the criteria referred to in subparagraph (1) above, at the end of each financial year.
- (3) A listed issuer must also ensure that a statement by the audit committee verifying such allocation is included in the annual report.

8.18 Termination of a share scheme for employees

- (1) A listed issuer may not terminate a share scheme for employees before expiry unless -
 - (a) The bylaws of the scheme contain a provision empowering the listed issuer to do so;
 - (b) The listed issuer obtains the prior approval of its shareholders; and
 - (c) The listed issuer obtains written consent of all option holders who have yet to exercise their options, whether partly or wholly.
- (2) A listed issuer must include the information set out in Appendix 8B in the circular sent to shareholders to obtain the approval of the shareholders in respect of the termination of a share scheme for employees.
- (3) The draft circular must be submitted to the Exchange together with a checklist showing compliance with Appendix 8B.
- (4) In seeking the consent of the option holders, the listed issuer must provide them with the information set out in Appendix 8B.

8.19 Implementation of a new share scheme for employees

A listed issuer that has implemented a share scheme for employees, must not implement a new scheme unless the existing scheme has expired or been terminated in accordance with paragraph 8.18.

8.20 Restriction on dealings

A non-executive director must not sell, transfer or assign shares obtained through the exercise of options offered to him pursuant to a share scheme for employees within 1 year from the date of offer of such options.

PART H - OTHERS**8.21 Material dilution**

- (1) A listed issuer must obtain shareholder approval in a general meeting for the issue by its principal subsidiary, of shares or convertible securities or options that results or could potentially result in a material dilution of the listed issuer's equity interest in such principal subsidiary.
- (2) For the purpose of subparagraph (1) above, unless the context otherwise requires -
 - (a) **"principal subsidiary"** means a subsidiary which accounts for 25% or more of the latest audited consolidated profit after tax of the group or total assets employed of the group; and
 - (b) **"material dilution"** means a percentage reduction amounting to 25% or more.

8.22 Material variations

- (1) Where a proposal has been approved by shareholders in general meeting and a listed issuer proposes to make a material amendment, modification or variation to such proposal, the listed issuer must issue a circular to its shareholders and seek its shareholder approval of such material amendment, modification or variation.
- (2) For the purpose of subparagraph (1) above, an amendment, modification or variation is considered material if it can be reasonably expected to have a material effect on the decision of a holder of securities of the listed issuer in relation to such proposal.
- (3) Subparagraph (1) above does not apply to any amendment, modification or variation resulting from such direction or condition as may be imposed by the relevant authorities.

8.23 Provision of financial assistance

- (1) Except as otherwise prohibited under the law or in relation to a foreign corporation, the relevant laws of the place of incorporation and subject to subparagraph (2) below, a listed issuer or its unlisted subsidiaries may only -
 - (a) lend or advance any money; or
 - (b) guarantee, indemnify or provide collateral for a debt,

("provision of financial assistance") to or in favour of the following:

 - (i) directors or employees of the listed issuer or its subsidiaries;
 - (ii) persons to whom the provision of financial assistance -
 - (aa) is necessary to facilitate the ordinary course of business of the listed issuer or its subsidiaries; or
 - (bb) pursuant to the ordinary course of business of the listed issuer or its subsidiaries;

such as the provision of advances to its sub-contractors or advances made to clients in the ordinary course of its moneylending business; or

-
- (iii) the subsidiaries or associated companies of the listed issuer, the listed issuer (in the case of the subsidiaries providing the financial assistance) or its immediate holding company which is listed.
- (2) Where a listed issuer or its subsidiaries provide financial assistance -
- (a) the board of directors of such listed issuer must ensure -
- (i) that the provision of the financial assistance referred to in subparagraph (1) above is fair and reasonable to the listed issuer and is not to the detriment of the listed issuer and its shareholders; and
- (ii) where a listed issuer or its subsidiary lends or advances money in the ordinary course of its business as a moneylender (“**moneylending company**” and “**moneylending operations**”), that the board of directors of the listed issuer oversees the moneylending operations and the management of credit risk of the moneylending company including ensuring that adequate policies and procedures are put in place which must be reviewed regularly to enable -
- (aa) maintenance of sound credit-granting standards;
- (bb) maintenance of a clear and defined credit approval process including a list of the approving party(ies), which must include the board of directors of the listed issuer, for different quantum of financial assistance granted by the moneylending company;
- (cc) monitoring and control of credit risk; and
- (dd) timely identification and administration of problem credits;
- (b) where it is a related party transaction as defined in paragraph 10.02, the listed issuer complies with the requirements of paragraph 10.08 in addition to this provision;
- (c) where the provision of financial assistance is to the associated company, and the aggregate amount provided or to be provided at any time to each associated company compared to the net tangible assets of the group is 5% or more, the listed issuer must issue a circular to its shareholders and seek its shareholder approval in general meeting of such provision of financial assistance;
- (d) where shareholder approval is required pursuant to subparagraphs (b) or (c) above, the listed issuer must state in its circular, the proposed utilisation of the amount of the financial assistance; and
- (e) in addition to the announcement as may be required by the Exchange, the listed issuer must announce the information set out in Appendix 8D in relation to each moneylending company for each quarter of its financial year, if any, not later than 7 market days after the end of each quarter of a financial year.
- (3) Except as otherwise prohibited under the law or in relation to a foreign corporation, the relevant laws of the place of incorporation and without limiting the generality of Part D of Chapter 2 -
- (a) a listed issuer or its directors must give the Exchange any information, document or explanation that the Exchange requests for in relation to moneylending operations in accordance with the instructions or request of the Exchange, including but not limited to the following information in relation to the 20 debtors of each moneylending company having the highest ~~outstanding~~ amount of outstanding loans and/or

advances (“**Loans**”) (with aggregation of Loans granted to persons connected with each other):

- (i) the names of the debtors and, in relation to each debtor, a statement as to whether the debtor is a related party;
 - (ii) the outstanding Loan amounts with aggregation of Loans granted to persons connected to each other, and the breakdown into principal and interest owing;
 - (iii) the salient terms of the outstanding Loans including the interest rate, terms as to the repayment of interest and principal and the security provided; and
 - (iv) the length of default on interest and/or principal, if applicable; and
- (b) the Exchange may, at its absolute discretion, forward such information, document or explanation to the relevant authorities including the SC.
- (4) Subparagraphs (1), (2) and (3) above do not apply to -
- (a) any provision of financial assistance provided to or in favour of the listed issuer or wholly owned subsidiaries of the listed issuer;
 - (b) a ~~company corporation~~ whose activities are regulated by any written law relating to banking, finance ~~companies corporations~~ or insurance and are subject to supervision by Bank Negara Malaysia.
 - (c) a ~~company corporation~~ which is registered as a scheduled institution with and supervised by Bank Negara Malaysia under the Banking and Financial Institutions Act 1989; or
 - (d) share financing or share margin financing carried out by a listed issuer or its unlisted subsidiary which is a Participating Organisation.

[Cross reference: Practice Note 11]

8.24 Listing of subsidiaries

A listed issuer must obtain shareholder approval if it wishes to list the securities of any of its subsidiaries on any stock exchange.

8.25 No alteration to or revocation of entitlement or books closing date after announcement of books closing date

- (1) ~~Where an entitlement is subject to the relevant authorities' approval.~~ A listed issuer must first procure ~~the relevant such~~ authorities' approval before fixing a books closing date.
- (2) Once the basis of an entitlement and the books closing date have been declared, a listed issuer must not make any subsequent alteration to or revocation of such entitlement or books closing date.

8.26 Declaration of dividend

- (1) Once the dividend has been declared, a listed issuer must not make any subsequent alteration to the dividend entitlement.
- (2) A listed issuer must ensure that all dividends are paid not later than 3 months from the date of declaration or the date on which approval is obtained in a general meeting, whichever is applicable.

8.27 Notices of general meetings

- (1) A listed issuer must ensure that all notices convening general meetings contain sufficient information to enable a member to decide whether to attend the meeting.
- (2) Without limiting the generality of subparagraph (1) above, a listed issuer must ensure that a notice convening an annual general meeting, where applicable, is accompanied by a statement which includes the information set out in Appendix 8A.
- (3) Any notice of a general meeting called to consider special business must be accompanied by an explanatory note which contains the necessary information to enable a member to make an informed decision. Such explanatory note must include the effect of any proposed resolution in respect of such special business.

8.28 Notice of maturity

The listed issuer must issue a notice of the maturity or expiry of any listed debt security or convertible security to its holders and advertise a summary of the same in at least one nationally circulated Bahasa Malaysia or English daily newspaper not less than 1 month before the last conversion/exercise date or maturity date, whichever is the earlier.

8.29 Securities holder approval

- (1) Where a transaction entered into or proposed to be entered into by a listed issuer or any other action or proposal of a listed issuer is specified in these Requirements as one which requires securities holder approval, such approval must be obtained before the transaction, action or proposal being completed.
- (2) Where the transaction entered into or proposed to be entered into by a listed issuer is the grant for the exercise of an option and shareholder approval is required pursuant to these Requirements, then -
 - (a) in the case of an issue by the listed issuer or its subsidiaries, the shareholder approval must be obtained before the option is issued, or the issue must be subject to that approval; and
 - (b) in the case of an exercise by the listed issuer or its subsidiaries, the shareholder approval must be obtained before an option is exercised.

8.30 Accounting and other records

A listed issuer must cause to be kept such accounting and other records as will sufficiently explain the financial position or operations of the listed issuer, including its subsidiaries.

8.31 Lodgement of agreement

Where any agreement has been entered into by a listed issuer or its subsidiaries in connection with any acquisition or disposal of assets or any transaction outside the ordinary course of business of a listed issuer or its subsidiaries, the listed issuer must make available for inspection a copy each of the relevant agreements at the listed issuer's registered office for a period of 3 months from the date of announcement.

PART I – SPECIFIC CONTINUING OBLIGATIONS RELATING TO PRICE STABILIZATION MECHANISM**8.32 Responsibilities of a listed issuer for the purposes of stabilizing action**

- (1) A listed issuer undertaking stabilizing actions must ensure that the register maintained by the stabilizing manager in accordance with subparagraph 10(a) of the Capital Markets and Services (Price Stabilization Mechanism) Regulations 2008, contains the information set out under Appendix 8C and that any changes to the information in the register be updated on a daily basis.
- (2) The listed issuer must make available the register and all agreements relating to the market stabilization made by the listed issuer and stabilizing manager to the SC, Exchange or a person authorized in writing by the Exchange for inspection and must allow the SC, Exchange or a person authorized in writing by the Exchange to make copies or take extracts from the register or the agreements.
- (3) Where a listed issuer is a foreign corporation, or a Malaysian company listed on both the Exchange and an exchange outside Malaysia, and a stabilizing manager outside Malaysia has been appointed to carry out any activities in respect of the securities of that foreign corporation or securities of that Malaysian company listed on both the Exchange and an exchange outside Malaysia, for the purposes of preventing or minimizing any reduction in the market price of such securities traded on a stock market outside Malaysia, such listed issuer must ensure that a register -
 - (a) contains information set out under Appendix 8C; and
 - (b) the register is capable of being brought into Malaysia and be made available for inspection by the SC, Exchange or a person authorized in writing by the Exchange or where such register is not capable of being brought into Malaysia, a certified true copy of the register must be made available for inspection by the SC, Exchange or a person authorized in writing by the Exchange.
- (4) For the purposes of this subparagraph, inspection includes making copies and taking extract from the register.

PART J - SPECIFIC CONTINUING OBLIGATIONS RELATING TO CLOSED-END FUNDS**8.33 Provision of information by Managers**

The Managers must submit to the Exchange any information relating to the closed-end fund, that the Exchange requests for and in accordance with the instructions or request of the Exchange.

~~8.34 — Application of other Chapters to closed-end funds~~

~~The provisions of paragraphs 8.11 and 9.28 do not apply to a closed-end fund.~~

PART K - SPECIFIC CONTINUING OBLIGATIONS RELATING TO REAL ESTATE INVESTMENT TRUSTS**~~8.3534~~ Distribution to be made in respect of real estate investment trusts**

Where a distribution is to be made to unit holders, the management company must make such distribution within 2 months after the books closing date.

8.3635 Unit spread of real estate investment trusts

The management company of must ensure that the real estate investment trust complies with the requirements of paragraph 8.02, as if the real estate investment trust is the listed issuer, the units are shares and the public unit holders are the public shareholders mentioned in paragraph 8.02.

8.3736 Application of other Chapters

Subject to paragraph 8.3837, ~~the provisions of paragraph 8.03,~~ Chapters 10 and 15 do not apply to a real estate investment trust except for paragraphs 15.03 and 15.06 to 15.08 which apply to the directors of the management company of the real estate investment trust.

8.3837 Submission of circulars to ~~Bursat~~the Exchange

- (1) When a real estate investment trust proposes to undertake a proposal which involves new issue of units or enter into a transaction which requires unit holders' approval under the SC's Guidelines on Real Estate Investment Trusts, the real estate investment trust must submit to the Exchange for perusal, 1 draft copy of all circulars and other documents proposed to be sent to its unit holders within a reasonable time before printing together with a checklist showing compliance with the relevant parts of these Requirement.
- (2) A real estate investment trust must include the information set out in Appendix 6B or Appendix 10B as may be applicable, in its circulars for the proposal or transaction referred to in subparagraph (1) above.

PART L - SPECIFIC CONTINUING OBLIGATIONS RELATING TO EXCHANGE TRADED FUNDS**8.3938 Application of other Chapters**

The provisions of Part E of Chapter 10, Chapters 14 and 15 do not apply to an exchange traded fund except for paragraphs 15.03 and 15.06 to 15.08 which apply to the directors of the management company of the exchange traded fund.

8.4039 Unit spread of exchange traded funds

The Exchange may require the management company of an exchange trade fund to comply with such unit spread requirements as may be prescribed by the Exchange in relation to an exchange traded fund, on a continuing basis.

8.4140 Submission of circulars to ~~Bursat~~the Exchange

- (1) When an exchange traded fund proposes to undertake a proposal which involves a new issue of units or enters into a transaction which requires unit holders' approval under the SC's ~~Guidelines on Exchange Traded Funds~~Exchange-Traded Funds Guidelines, the exchange traded fund must submit to the Exchange for perusal, 1 draft copy of all circulars and other documents proposed to be sent to its unit holders within a reasonable time prior to the printing together with a checklist showing compliance with the relevant parts of these Requirements.
- (2) An exchange traded fund must include the information set out in Appendix 6B or Appendix 10B as may be applicable, in its circulars for the proposal or transaction referred to in subparagraph (1) above.

PART M - SPECIFIC CONTINUING OBLIGATIONS RELATING TO SPECIAL PURPOSE ACQUISITION COMPANIES**8.4241 Provision and obtaining financial assistance**

Notwithstanding paragraph 8.23, a SPAC must not provide any financial assistance to any person until it has fully paid or satisfied the consideration of the qualifying acquisition and the ownership of the assets acquired by the SPAC is beneficially and legally vested in the SPAC.

8.4342 Application of other continuing listing obligations

A SPAC is not subject to the continuing listing obligations set out in the following paragraphs or parts of this Chapter:

- (a) paragraph 8.11;
- (b) Part D;
- (c) Part E; and
- (d) Part G.

[End of Chapter]

Appendix 8A
Contents of statement accompanying notices of AGM

APPENDIX 8A**Contents of statement accompanying notices of annual general meetings**
(paragraph 8.27(2))

Further details of individuals who are standing for election as directors (excluding directors standing for a re-election), namely the following:

- (a) the name, age, nationality, qualification, and whether the position is an executive or non-executive one and whether such director is an independent director;
- (b) the working experience and occupation;
- (c) any other directorships of public companies;
- (d) the details of any interest in the securities of the listed issuer and its subsidiaries;
- (e) the family relationship with any director and/or major shareholder of the listed issuer;
- (f) any conflict of interests that they have with the listed issuer; and
- (g) the list of convictions for offences within the past 10 years other than traffic offences, if any.

[End of Appendix]

Appendix 8B
Contents of circular to terminate a share scheme for employees

APPENDIX 8B**Contents of circular to shareholders to terminate a share scheme for employees**
(paragraph 8.18)

- (1) A statement that Bursa Malaysia Securities Berhad takes no responsibility for the contents of the circular, makes no representation as to its accuracy or completeness and expressly disclaims any liability whatsoever for any loss howsoever arising from or in reliance upon the whole or any part of the contents of the circular.
- (2) The rationale for termination of the scheme.
- (3) A statement by the board of directors stating whether the termination is in the best interests of the listed issuer, and where a director disagrees with such statement, a statement by such director setting out the reasons and factors taken into consideration in forming that opinion.
- (4) Any other information that would justify the termination of the scheme.

[- End of Appendix -]

Appendix 8C
Information to be included in the register of a stabilizing manager

APPENDIX 8C**Information to be included in the register of a stabilizing manager**
(paragraph 8.32)

- (1) The name of the issuer whose securities are subject to stabilization action.
- (2) Details of the number of shares over allotted, name of lender, amount of shares borrowed and price of the relevant securities and total amount of option exercised.
- (3) The names and addresses of the person appointed as a stabilizing manager, contact person, name of the Participating Organisation and the Capital Markets Services Representative's License holder that will be conducting the stabilizing action (or equivalent, if any); and salient terms of all agreements relating to the market stabilization made by the listed issuer and stabilizing manager.
- (4) A daily breakdown of the transactions effected during the stabilizing period showing the total number of shares purchased each day and the purchase price per share or the highest, lowest and average paid.

[-End of Appendix-]

APPENDIX 8D**Information to be included in announcement by moneylending company**
(paragraph 8.23(2)(e))

- (1) **†**The aggregate amount of outstanding loans and/or advances (“Loans”) given by the moneylending company setting out the following breakdown for secured and unsecured Loans:
 - (a) to ~~companies~~corporations;
 - (b) to individuals;
 - (c) to ~~companies~~corporations within the listed issuer group; and
 - (d) to related parties.

- (2) **†**The total borrowings, setting out -
 - (a) the Loans given by any ~~company~~corporation within the listed issuer group to the moneylending company;
 - (b) the borrowings which are secured by any ~~company~~corporation within the listed issuer group in favour of the moneylending company; and
 - (c) other borrowings.

- (3) **†**The aggregate amount of Loans in default which must include the movements in the Loans in default for the listed issuer and the group as follows:
 - (a) at the beginning of the year;
 - (b) classified as Loans in default during the financial year;
 - (c) reclassified as performing during the financial year;
 - (d) amount recovered;
 - (e) amount written off;
 - (f) Loans converted to securities;
 - (g) total and net Loans in default at the end of the year; and
 - (h) ratio of net Loans in default to net Loans or advances.

For this purpose, a Loan in default will be as determined by the listed issuer but must in any event, include a situation where the debtor has been in default of payment of either interest or principal sums or both for 3 months or more in respect of a Loan. In this regard, only Loans by a debtor to the moneylending company may be set off in ascertaining the outstanding Loans of the debtor to such company.

- (4) **†**The top 5 Loans (with aggregation of Loans given to the same person or persons connected with each other), setting out (where applicable) -
 - (a) the facility type and limit;

Appendix 8D
Announcement by moneylending company

- (b) the amount outstanding and type;
- (c) whether security was provided and if provided, the value of the security;
- (d) whether the recipient of the Loans is a related party; and
- (e) the terms of repayment.

[End of Appendix]

CHAPTER 9 CONTINUING DISCLOSURE**PART A - GENERAL****9.01 Introduction**

- (1) This Chapter sets out the continuing disclosure requirements that must be complied with, amongst others, by a listed issuer, its directors or advisers.
- (2) The disclosure requirements set out in this Chapter consist of the following:
 - (a) ~~C~~orporate ~~D~~isclosure ~~P~~olicy of the Exchange (Parts B to H);
 - (b) ~~P~~reparation of announcements (Part I);
 - (c) ~~I~~mmEDIATE disclosure requirements (Part J);
 - (d) ~~P~~eriodic disclosure requirements (Part K);
 - (f) ~~C~~irculars and other requirements (Part L); and
 - (e) ~~D~~isclosure requirements for specific listed issuers (Part M).
- (3) Continuing disclosure is the timely and accurate disclosure of all material information by a listed issuer to the public.
- (4) Continuing disclosure ensures a credible and responsible market in which participants conduct themselves with the highest standards of due diligence and investors have access to timely and accurate information to facilitate the evaluation of securities.

PART B - CORPORATE DISCLOSURE POLICY**9.02 Corporate ~~D~~isclosure ~~P~~olicy**

- (1) A listed issuer must, in accordance with these Requirements, disclose to the public all material information necessary for informed investing and take reasonable steps to ensure that all who invest in its securities enjoy equal access to such information.
- (2) A listed issuer must adhere to the following 6 specific policies concerning disclosure, which are as follows:
 - (a) ~~I~~mmEDIATE disclosure of material information (Part C);
 - (b) ~~T~~horough public dissemination (Part D);
 - (c) ~~C~~larification, confirmation or denial of rumours or reports (Part E);
 - (d) ~~R~~esponse to unusual market activity (Part F);
 - (e) ~~U~~nwarranted promotional disclosure activity (Part G); and
 - (f) ~~I~~nsider trading (Part H).

PART C - IMMEDIATE DISCLOSURE OF MATERIAL INFORMATION**9.03 Disclosure of material information**

- (1) A listed issuer must make immediate public disclosure of any material information, except as set out in paragraph 9.05 below.
- (2) Information is considered material, if it is reasonably expected to have a material effect on -
 - (a) the price, value or market activity of any of the listed issuer's securities; or
 - (b) the decision of a holder of securities of the listed issuer or an investor in determining his choice of action.
- (3) Without limiting the generality of subparagraph (2) above, material information may include information which -
 - (a) concerns the listed issuer's assets and liabilities, business, financial condition or prospects;
 - (b) relates to dealings with employees, suppliers, customers and others;
 - (c) relates to any event affecting the present or potential dilution of the rights or interests of the listed issuer's securities; or
 - (d) relates to any event materially affecting the size of the public holding of its securities.

[Cross reference: [Practice Notes 1](#); ~~[Practice Note and 3](#)~~]

9.04 Examples of events which may require immediate disclosure

The following are some examples of events which may require immediate disclosure by the listed issuer:

- (a) the entry into a joint venture agreement or merger;
- (b) the acquisition or loss of a contract, franchise or distributorship rights;
- (c) the introduction of a new product or discovery;
- (d) a change in management;
- (e) the borrowing of funds;
- (f) the commencement of or the involvement in litigation and any material development arising from such litigation;
- (g) the commencement of arbitration proceedings or proceedings involving alternative dispute resolution methods and any material development arising from such proceedings;
- (h) the purchase or sale of an asset;
- (i) a change in capital investment plans;
- (j) the occurrence of a labour dispute or disputes with sub-contractors or suppliers;
- (k) the making of a tender offer for another corporation's securities;

-
- (l) the occurrence of an event of default on interest, principal payments or both in respect of loans;

[Cross reference: Practice Note 1]

- (m) a change in general business direction;
- (n) a change of intellectual property rights;
- (o) the entry into a memorandum of understanding; or
- (p) the entry into any call or put option or financial futures contract.

9.05 Withholding of material information

- (1) A listed issuer may, in exceptional circumstances, temporarily refrain from publicly disclosing material information, provided that complete confidentiality is maintained. Where material information is withheld, the listed issuer must refrain from delaying disclosure for an unreasonable period of time since it is unlikely that confidentiality can be maintained beyond a short period of time.
- (2) The exceptional circumstances where disclosures can be withheld are limited and constitute an infrequent exception to the normal requirement of immediate public disclosure. In cases of doubt, the presumption must always be in favour of disclosure.
- (3) The following are some exceptional circumstances where disclosure may be temporarily withheld:
- (a) when immediate disclosure would prejudice the ability of the listed issuer to pursue its corporate objectives. Public disclosure of a plan to acquire certain real estate for example, could result in an increase in the listed issuer's cost of the desired acquisition or could prevent the listed issuer from carrying out the plan at all. In such circumstances, if the unfavourable result to the listed issuer outweighs the undesirable consequences of non-disclosure, disclosure may properly be deferred to a more appropriate time;
- (b) when the facts are in a state of flux and a more appropriate moment for disclosure is imminent.

Occasionally, corporate developments give rise to information which, although material, is subject to rapid change. If the situation is about to stabilise or resolve itself in the near future, it may be proper to withhold public announcement until a firm announcement may be made, since successive public announcements concerning the same subject but based on changing facts may confuse or mislead the public rather than enlighten it. In the course of a successful negotiation for the acquisition of another corporation, for example, the only information known to each party at the outset may be the willingness of the other to hold discussions. Shortly thereafter ~~thereafter~~ that, it may become apparent to the parties that it is likely an agreement can be reached. Finally, an agreement in principle may be reached on specific terms. In such circumstances a listed issuer need not issue a public announcement at each stage of the negotiations, describing the current state of constantly changing facts but may await agreement in principle on specific terms. If, on the other hand, progress in the negotiations should stabilise at some other point, disclosure should then be made if the information is material; or

- (c) where company or securities laws may restrict the extent of permissible disclosure before or during a public offering of securities or a solicitation of proxies.

9.06 Maintaining confidentiality

- (1) Whenever material information is being temporarily withheld, a listed issuer must ensure that the strictest confidentiality is maintained.
- (2) The listed issuer should limit the number of people with access to the material information and ensure the security of all confidential documents.
- (3) Notwithstanding paragraph 9.05 above, in the event that material information is or is believed to have been inadvertently disclosed to third parties or where the material information has become generally available through the media or otherwise, the listed issuer must immediately announce the information to the Exchange.

9.07 Monitoring of market activity and making of announcements

During a period where information is withheld, the market activity of the listed issuer's securities must be closely monitored. The listed issuer must immediately announce the information withheld to the Exchange, in the following circumstances:

- (a) unusual market activity in the listed issuer's securities which signifies that a "leak" of the information may have occurred;
- (b) rumours or reports concerning the information have appeared; or
- (c) where the listed issuer learns that there are signs that insider trading may be taking place.

PART D - THOROUGH PUBLIC DISSEMINATION**9.08 Thorough public dissemination**

- (1) A listed issuer must release material information to the public in a manner designed to obtain its fullest possible public dissemination.
- (2) A listed issuer must ensure that no disclosure of material information is made on an individual or selective basis to analysts, shareholders, journalists or other persons unless such information has previously been fully disclosed and disseminated to the public. In the event that material information is inadvertently disclosed on the occasion of any meetings with analysts, shareholders, journalists or others, it must be publicly disseminated as promptly as possible.
- (3) There may be limited circumstances where selective disclosure of material information is necessary, for example where the listed issuer is undertaking a corporate exercise or to facilitate a due diligence exercise. In such circumstances, the listed issuer must ensure that the disclosure is restricted to only relevant persons and the strictest confidentiality is maintained.
- (4) Disclosures of material information can often be made after the market closes. If the disclosure is made immediately before or during trading hours, the Exchange may impose a temporary halt or suspension in trading of the listed issuer's securities. Such a temporary halt or suspension provides an opportunity for the dissemination and evaluation of the information released.
- (5) Any public disclosure of material information must be made by an announcement first to the Exchange or simultaneously to the Exchange, the press and newswire services. For the avoidance of doubt, a listed issuer must not release any material information to the media even on an embargoed basis until it has given the information to the Exchange.

PART E - CLARIFICATION, CONFIRMATION OR DENIAL OF RUMOURS OR REPORTS**9.09 Clarification, confirmation or denial of rumours or reports**

- (1) Whenever a listed issuer becomes aware of any rumour or report, true or false, that contains material information, the listed issuer must make due enquiry and immediately publicly clarify, confirm or deny the rumour or report.
- (2) For the purpose of subparagraph (1) above, the listed issuer must publicly clarify any rumour or report which is in any form whatsoever and howsoever including that by word-of-mouth and not limited to an article or otherwise, published in a newspaper, newswire, magazine, a broker's market report or any other publication.

9.10 Response to rumour or report

- (1) In the case of a rumour or report containing erroneous material information which has been circulated, the listed issuer must immediately announce to the Exchange a denial or clarification of the rumour or report and provide facts sufficient to support the denial or to clarify any misleading aspects of the rumour or report. A reasonable effort must be made to bring the announcement to the attention of the particular group that initially distributed it. In the case of an erroneous newspaper article, for example, this should be done by sending a copy of the announcement to the newspaper's financial editor, or in the case of an erroneous broker's market report, by sending a copy to the broker responsible for the report.
- (2) In the case of a rumour or report containing material information that is correct, an announcement setting forth the facts must be prepared for public release, which must include but not be limited to, an indication of the state of negotiations or of corporate plans in the rumoured area. Such announcements are essential even if the matter has yet to be presented to the listed issuer's board of directors for consideration.
- (3) In the case of a rumour or report predicting future sales, earnings or other quantitative data, no response from the listed issuer is ordinarily required. However, if such a report is manifestly based on or contains erroneous information, or is wrongly attributed to the listed issuer, the listed issuer must respond promptly to the supposedly factual elements of the rumour or report as required under paragraph 9.09 and this paragraph 9.10. In addition, the listed issuer must include in the announcement a statement to the effect that the listed issuer itself has made no such prediction and currently knows of no facts that would justify making such a prediction.

PART F - RESPONSE TO UNUSUAL MARKET ACTIVITY**9.11 Unusual market activity**

- (1) Where unusual price movement, trading activity, or both ("**unusual market activity**") occurs, the listed issuer must immediately undertake a due enquiry to seek the cause of the unusual market activity in its securities. The listed issuer must consider in particular whether there is any information concerning the listed issuer which would account for the unusual market activity that -
 - (a) has recently been publicly disclosed;
 - (b) has not been publicly disclosed (in which case the unusual market activity may signify that a "leak" has occurred); or
 - (c) is the subject matter of a rumour or report.

-
- (2) If the listed issuer determines that the unusual market activity results from material information that has already been publicly disclosed pursuant to these Requirements, generally no further announcement is required, although, if the unusual market activity indicates that such information may have been misinterpreted, the listed issuer must issue a clarifying announcement to the Exchange.
 - (3) If the unusual market activity results from a “leak” of previously undisclosed information, the information in question must be publicly disclosed by the listed issuer in accordance with these Requirements.
 - (4) If the unusual market activity results from a rumour or report, the listed issuer must comply with paragraphs 9.09 and 9.10 above.
 - (5) Finally, if the listed issuer is unable to determine the cause of the unusual market activity, the listed issuer must announce that there have been no undisclosed developments which would account for the unusual market activity.

PART G - UNWARRANTED PROMOTIONAL DISCLOSURE ACTIVITY

9.12 Promotional disclosure activity

- (1) A listed issuer must refrain from promotional disclosure activity in any form whatsoever or howsoever which may mislead investors or cause unwarranted price movement and activity in a listed issuer’s securities.
- (2) Such activity includes news releases, public announcements, predictions, reports or advertisements which are -
 - (a) not justified by actual developments concerning a listed issuer;
 - (b) exaggerated;
 - (c) flamboyant;
 - (d) overstated; or
 - (e) over-zealous.

9.13 Hallmarks of promotional disclosure activity

Although the distinction between legitimate public relations activities and such promotional disclosure activity is one that must necessarily be drawn from the facts of a particular case, the following are frequent hallmarks of promotional activity:

- (a) a series of public announcements unrelated in volume or frequency to the materiality of actual developments concerning a listed issuer;
- (b) announcement of products still in the development stage with unproven commercial prospects;
- (c) promotions and expense-paid trips, or the seeking out of meetings or interviews with analysts and financial writers, which could have the effect of unduly influencing the market activity in the listed issuer’s securities and are not justified in frequency or scope by the need to disseminate information about actual developments concerning the listed issuer;
- (d) press releases or other public announcements of a one-sided or unbalanced nature; and

-
- (e) listed issuer's or product advertisements which in effect promote the listed issuer's securities.

PART H - INSIDER TRADING

9.14 Prohibitions under the law

- (1) All listed issuers and parties who may be regarded as insiders must be fully aware of the provisions of the CMSA and the Companies Act 1965.
- (2) For the purpose of this Part, "insider" has the meaning given under section 188 of the CMSA.

9.15 Prohibition from trading

Insiders must not trade on the basis of material information which is not known to the investing public.

PART I - PREPARATION OF ANNOUNCEMENTS

9.16 Content of press or other public announcement

- (1) The content of a press or other public announcement is as important as its timing. A listed issuer must ensure that each announcement -
- (a) is factual, clear, unambiguous, accurate, succinct and contains sufficient information to enable investors to make informed investment decisions;
 - (b) is not false, misleading or deceptive, and does not contain any language which is inflammatory, defamatory or scandalous of another person;
 - (c) is balanced and fair. Thus, the announcement must avoid amongst others -
 - (i) the omission of material facts;
 - (ii) the omission of material unfavourable facts, or the slighting of such facts (e.g. by "burying" them at the end of a press release);
 - (iii) the presentation of favourable possibilities as certain, or as more probable than is actually the case;
 - (iv) the representation with respect to any future performance, occurrence or matter (including the doing of, or the refusing to do, any act) without adequate justification (supported by proper bases and assumptions) or any reasonable grounds for making ~~of~~ such representation;
 - (v) the presentation of revenue or profit estimate, forecast or projection without sufficient qualification, assumptions or factual basis. If any revenue or profit estimate, forecast or projection is released, it must be prepared carefully, with a reasonable factual basis and be stated realistically, with appropriate assumptions and qualifications, so as to ensure that it is properly understood. In addition, the accounting bases and calculations of the estimate, forecast or projection and the assumptions must be reviewed by the external auditors except where the revenue or profit estimate, forecast or projection is required to be released on an immediate basis;
 - (vi) negative statements phrased so as to create a positive implication, e.g. "The company cannot now predict whether the development will have a materially

- favourable effect on its earnings” (creating the implication that the effect will be favourable even if not materially favourable), or “The company expects that the developments will not have a materially favourable effect on earnings in the immediate future” (creating the implication that the development will eventually have a materially favourable effect); or
- (vii) the use of promotional jargon calculated to induce investment or create interest in the securities of the listed issuer rather than to inform;
 - (d) avoids over-technical language, and is expressed to the extent possible in language comprehensible to the layman;
 - (e) explains, if the consequences or effects of the information on the listed issuer’s future prospects cannot be assessed, why this is so; and
 - (f) explains, in relation to an announcement on internal targets, that the information disclosed ~~are~~is merely internal management targets or aspirations set to be achieved by the listed issuer and not an estimate, forecast or projection.
- (2) Where an adviser is appointed by the listed issuer for submission of the announcement to the Exchange, such adviser must also comply with subparagraph (1) above.
- (3) A listed issuer or its adviser does not commit a breach of subparagraphs (1) or (2) above, as the case may be, if such person proves that -
- (a) he had made all enquiries as were reasonable in the circumstances; and
 - (b) after making such enquiries, he had reasonable grounds to believe and did believe until the submission of the announcement that the announcement did fulfil the requirements of subparagraph (1) above.
- (4) Where any announcement referred to in subparagraph (1) above has been submitted to the Exchange and the person referred to in subparagraphs (1) or (2) above subsequently becomes aware that the announcement may not fulfil the requirements of subparagraph (1) above, the person must ~~forthwith~~immediately notify the Exchange of the same.

[Cross reference: [Practice Notes 1](#); ~~Practice Note~~ [and 3](#)]

9.17 Preparation of press or public announcement

A listed issuer must comply with the following requirements in respect of its obligation to make disclosure of information under these Requirements:

- (a) since skill and experience are important to the preparation and editing of press or public announcements, the Exchange requires that the listed issuer identify an individual or limited group of individuals within the listed issuer who are familiar with the requirements of the Exchange, as well as any applicable requirements of the securities laws to undertake the responsibility for disclosure on a continuing basis. As a press or public announcement must usually be prepared and released as quickly as possible, the individual or group charged with this assignment must be able to handle problems that arise suddenly and unexpectedly; and
- (b) every announcement must be reviewed by a company official familiar with the matters about which disclosure is to be made.

9.18 Summary of salient points

- (1) All lengthy announcements to the Exchange should preferably be prefaced by a summary of salient points.

-
- (2) Where a summary is provided, the listed issuer must ensure that -
- (a) the summary is in a form suitable for immediate dissemination by the Exchange; and
 - (b) the summary is clear and is an accurate reflection of the announcement.

PART J - IMMEDIATE DISCLOSURE REQUIREMENTS

9.19 Immediate announcements to the Exchange

A listed issuer must immediately announce to the Exchange the following events. This requirement is in addition to the other announcement requirements which are imposed under this Chapter and other parts of these Requirements, and are not exhaustive -

- (1) any intention to fix a books closing date and its reason, stating the books closing date, which must be at least 10 market days after the date of announcement to the Exchange;
- (2) any recommendation or declaration of a dividend or distribution. The announcement must include the rate and amount per share and date of payment which is within 1 month from the books closing date. Where a dividend or distribution is not taxable in the hands of shareholders, this must be stated in the announcement to the Exchange and on the dividend or distribution advice to shareholders. Where there is a variation in an interim or a final dividend or distribution for the corresponding period in the previous year, the directors must state the reasons for the variation at the time of the recommendation or declaration;
- (3) any recommendation or decision that a dividend will not be declared;
- (4) any change in the terms of a debt security or a convertible security;
- (5) any re-organisation of the group structure of the listed issuer;
- (6) any general meeting (other than a meeting convened to pass a special resolution or an annual general meeting), at least 14 days before such meeting is held, and in the case of a meeting convened to pass a special resolution or to hold an annual general meeting, at least 21 days before such meeting is held;
- (7) all resolutions put to a general meeting of a listed issuer and immediately after such meeting whether or not the resolutions were carried;
- (8) any call to be made upon any of the partly paid share capital of the listed issuer;
- (9) any change of address or telephone number and/or facsimile number of the registered office of the listed issuer or of any office at which the register of securities of the listed issuer is kept;
- (10) any proposed change of name of the listed issuer;
- (11) any change in the financial year end of the listed issuer;
- (12) any change in the composition of the board of directors. An announcement to the Exchange on the appointment of directors must include the information contained in Part A of Appendix 9A;
- (13) any change in the composition of the audit committee of the listed issuer. An announcement to the Exchange on the appointment of audit committee members must state whether the appointees are independent directors;

-
- (14) any change or proposed change in the chief executive of the listed issuer. An announcement to the Exchange on the appointment of a chief executive must include the information contained in Part B of Appendix 9A;
 - (15) any change in the company secretary or external auditors of the listed issuer;
 - (16) any proposed alteration of the memorandum of association or articles of association of the listed issuer;
 - (17) any notice relating to substantial shareholding which the listed issuer has received;
 - (18) any notice referred to in section 135(1) of the Companies Act 1965 which the listed issuer has received in relation to the listed issuer's securities listed on the Exchange;
 - (19) any commencement of winding-up proceedings or winding-up order made against the listed issuer or any of its subsidiaries or major associated companies. "**Commencement of winding-up**" has the meaning given under sections 219 and 255 of the Companies Act 1965. An announcement to the Exchange pertaining to the winding-up must include the information contained in Part C of Appendix 9A;
 - (20) the appointment of a receiver, manager or receiver and manager, liquidator (which includes a provisional liquidator) or special administrator or such other person of a similar capacity over the listed issuer, any of its subsidiaries or major associated companies or any part of the properties of the listed issuer, any of its subsidiaries or major associated companies. An announcement pertaining to the appointment of a receiver, manager or receiver and manager or such other person of a similar capacity, must include the information contained in Part D of Appendix 9A. An announcement on the appointment of the liquidator (which includes a provisional liquidator) or special administrator must include the information contained in Part E of Appendix 9A;
 - (21) the procurement of a court order restraining proceedings against a listed issuer or any of its subsidiaries or major associated companies under section 176 of the Companies Act 1965. An announcement on the restraining order must include the information contained in Part F of Appendix 9A;
 - (22) any transaction requiring an announcement to be made under Chapter 10 of these Requirements;
 - (23) any acquisition (including subscription) of shares in another company corporation or any other event which results in such company becoming a subsidiary of the listed issuer;
 - (24) any disposal of shares in another corporation or any other event which results in such corporation ceasing to be a subsidiary of the listed issuer;
 - (25) any acquisition (including subscription) of shares in another listed issuer or any other event which results in the holding being 5% or more of the issued and paid-up capital (excluding treasury shares) of that listed issuer;
 - (26) any disposal of shares in another listed issuer or any other event which results in the holding falling below 5% of the issued and paid-up capital (excluding treasury shares) of that listed issuer;
 - (27) any proposed issue or offer of securities by the listed issuer;
 - (28) any scheme of compromise, arrangement, amalgamation or reconstruction;
 - (29) any variation of the rights attaching to a class of securities of the listed issuer;

-
- (30) the level of subscription in relation to an issue or offer of securities by the listed issuer;
 - (31) the decision to allocate excess securities in relation to a rights issue by the listed issuer and the basis of such allocation;
 - (32) any change to the utilisation of proceeds raised by the listed issuer from the issuance of securities that deviates by 5% or more from the original utilisation of proceeds;
 - (33) a subdivision of shares or consolidation by the listed issuer;
 - (34) any deviation of 10% or more between the profit after tax and minority interest stated in a profit estimate, forecast or projection previously announced or disclosed in a public document and the announced unaudited financial statements, giving an explanation of the deviation and the reconciliation of the deviation;
 - (35) any deviation of 10% or more between the profit or loss after tax and minority interest stated in the announced unaudited financial statements and the audited financial statements, giving an explanation of the deviation and the reconciliation -of the deviation;
 - (36) any circumstances or development which are likely to materially affect the results or outcome of any prospects, revenue or profit estimate, forecast, projection or internal targets of the listed issuer previously announced or disclosed in a public document, giving an explanation of the possible outcome arising from such circumstances or development on the prospects, revenue or profit estimate, forecast, projection or internal targets of the listed issuer;
 - (37) any qualification in an external auditors' report giving full details of such qualification;
 - (38) a call of securities for redemption by the listed issuer;
 - (39) any listing of any part of the securities of a listed issuer or any of its subsidiaries on any other stock exchange, stating which other stock exchange;
 - (40) any material information or financial documents that is released to or lodged with any other stock exchange or other regulator which is available to the public;
 - (41) any change of control in the listed issuer;
 - (42) any agreement to sponsor a depository receipt programme. An announcement -must include the information contained in Part G of Appendix 9A;
 - (43) any material amendment of the terms of the agreement for the sponsorship of a depository receipt programme, or the termination of such programme, stating the reasons and consequences of the termination;
 - (44) any discovery of mineralisation or hydrocarbons by a listed issuer or its subsidiaries whose activities include exploration for natural resources stating whether any of the figures or estimates in the discovery have been verified by a geologist, or other expert, and if so, particulars of the geologist or expert;
 - (45) any pending litigation or occurrence of circumstances of a material nature in which the listed issuer being a mining, plantation or timber company-corporation or any of its subsidiaries may be involved which may affect its income derived from title to or possession of any of its properties, licences or concessions from governmental authorities;
 - (46) any valuation which has been conducted on the non-current assets of the group, where the revaluation surplus or deficit will be incorporated in the financial statements of the listed issuer. The listed issuer must announce the valuation upon the listed issuer's board approving the incorporation of the revaluation surplus or deficit in the financial statements of

the listed issuer and must include the information contained in Part H of Appendix 9A in the announcement to the Exchange. The listed issuer must make available a copy each of the valuation reports for inspection at the listed issuer's registered office for a period of 3 months from the date of announcement;

- (47) any material development to corporate proposals previously announced, including the following:
- (a) variation of terms, including any extension of time agreed to or granted by the relevant party to the transaction;
 - (b) lapse of any timeframe stipulated under the agreement for the performance of certain obligations;
 - (c) submission of the proposal and any variation to regulatory authorities for approval;
 - (d) receipt of any decision from regulatory authorities, stating amongst others, conditions imposed or reasons for rejection, where applicable;
 - (e) submission of any application to the regulatory authorities for variation of conditions;
 - (f) lapse of timeframe imposed by the relevant regulatory authorities, within which the corporate proposal must be completed and the submission of any application for extension of time to complete implementation of the corporate proposal; and
 - (g) termination or completion of the corporate proposal; or
- (48) in relation to a take-over offer for the acquisition of the listed shares of a listed issuer pursuant to the Take-Overs and Mergers Code or a corporate proposal undertaken by or in relation to a listed issuer, upon 90% or more of the listed shares (excluding treasury shares) of the said listed issuer being held by a shareholder either individually or jointly with associates of the said shareholder. In relation to a take-over offer, the listed issuer must include the information contained in Part J of Appendix 9A in the announcement to the Exchange.

9.20 Dealings in quoted securities

- (1) A listed issuer must immediately announce to the Exchange any purchase or sale of securities quoted on the Exchange or any other stock exchange ("**quoted securities**"-) entered into by the listed issuer or any of its subsidiaries, resulting in the purchase or sale consideration when aggregated with any other purchase or sale, respectively within the preceding 12 months (excluding such purchase or sale which has been previously announced by the listed issuer pursuant to this paragraph), being 5% or more of the listed issuer's latest audited consolidated net assets. The listed issuer must include the following in the announcement to the Exchange:
- (a) the aggregate purchase or sale consideration within the preceding 12 months which have not been previously announced and such amount as a percentage of the latest audited consolidated net assets of the listed issuer;
 - (b) the total cost, book value and market value of all investments in quoted securities as at the date of the announcement; and
 - (c) any profit or loss arising from the sales in quoted securities during the current financial year.
- (2) Subparagraph (1) above does not apply to -
- (a) a closed-end fund;

- (b) a ~~company corporation~~ whose activities are regulated by any written law relating to banking, finance ~~companies corporations~~ or insurance and are subject to supervision by Bank Negara Malaysia;
- (c) a Participating Organisation;
- (d) purchases or sales in an existing subsidiary or associated company of the listed issuer; or
- (e) an exchange-~~traded~~ fund.

9.21 Listed issuer to have a website

- (1) Every listed issuer must have its own website.
- (2) A listed issuer must publish on its website all announcements made to the Exchange pursuant to these Requirements. The listed issuer must ensure that such announcements are placed on the listed issuer's website, as soon as practicable after the same are released on the Exchange's website.
- (3) A listed issuer must ensure that its website contains the email address, name(s) of designated person(s) and their contact numbers to enable the public to forward queries to the listed issuer.
- (4) A listed issuer should ensure that its website is current, informative and contains all information which may be relevant to the listed issuer's shareholders including analyst's briefings.

PART K - PERIODIC DISCLOSURES

9.22 Quarterly report

- (1) A listed issuer must announce to the Exchange, an interim financial report that is prepared on a quarterly basis ("**quarterly report**")~~-~~, as soon as the figures have been approved by the board of directors of the listed issuer, and in any event not later than 2 months after the end of each quarter of a financial year.
- (2) The listed issuer must include in the quarterly report, the information set out in Part A of Appendix 9B and any other information as may be required by the Exchange.
- (3) If a change in the financial year is proposed by a listed issuer, such listed issuer must consult the Exchange as to the period to be covered by the quarterly report.

9.23 Issue of annual audited financial statements and annual report

- (1) A listed issuer must issue its annual reports that includes annual audited financial statements together with the auditors' and directors' reports of the listed issuer, and forward them to the Exchange and shareholders within 6 months from the close of the financial year of the listed issuer.
- (2) A listed issuer must announce to the Exchange its ~~the~~ annual audited financial statements together with the auditors' and directors' reports within a period not more than 4 months from the close of the financial year of the listed issuer unless the annual report is issued within a period of 4 months from the close of the financial year of the listed issuer.

9.24 Annual audited financial statements in consolidated form

A listed issuer must prepare the annual audited financial statements on a consolidated basis.

9.25 Disclosure in annual report

- (1) A listed issuer must set out separately in its annual report, the items set out in Part A of Appendix 9C.
- (2) Unless otherwise specified in Part A of Appendix 9C, the information provided pursuant to Part A of Appendix 9C must be information made up to a date not earlier than 6 weeks from the date of the notice of the annual general meeting in the annual report of the listed issuer.

9.26 Issuance of annual report in CD-ROM

Without prejudice to other provisions relating to issuance of annual reports, a listed issuer may issue its annual report in CD-ROM to its shareholders provided that it -

- (a) gives a printed copy of its annual report to its shareholder upon the shareholder's request, whether verbal or written;
- (b) designates a person to attend to the shareholders' requests as stated in subparagraph (a) above;
- (c) ensures that a hard copy of the annual report is forwarded to the shareholder requesting the same within 4 market days from the date of receipt of the request;
- (d) designates person(s) to answer queries from shareholders relating to the use of the CD-ROM; **and**
- (e) issues hard copies of the notice of the annual general meeting, the proxy form and the following documents to its shareholders together with the CD-ROM annual report -
 - (i) a note containing the following statement or information:
 - (aa) the listed issuer will forward a hard copy of the annual report to the shareholder within 4 market days from the date of receipt of the verbal or written request;
 - (bb) the listed issuer's website and e-mail address, name(s) of designated person(s) attending to shareholders' requests and queries and contact number(s); and
 - (cc) the designated website link or address where a copy of the annual report may be downloaded; and
 - (ii) a request form to enable the shareholder to request for the annual report in hard copy, with the particulars of the listed issuer's facsimile number and mailing address.

9.27 Statutory declaration in relation to accounts

A listed issuer must ensure that the director or person primarily responsible for the financial management of the listed issuer, as the case may be, who signs the statutory declaration pursuant to section 169(16) of the Companies Act 1965 ("**signatory**") satisfies the following requirements:

- (a) the signatory is a member of the Malaysian Institute of Accountants; or

- (b) if the signatory is not a member of the Malaysian Institute of Accountants, the signatory has at least 3 years' working experience and -
- (i) has passed the examinations specified in Part I of the ~~1st~~ First Schedule of the Accountants Act 1967; or
 - (ii) is a member of one of the associations of accountants specified in Part II of the ~~1st~~ First Schedule of the Accountants Act 1967; or
- (c) the signatory fulfils such other requirements as prescribed or approved by the Exchange.

[Cross reference: Practice Note 13]

9.28 Suspension or de-listing for failure to comply

- (1) A listed issuer must comply with the timeframes stated in paragraphs 9.22 and 9.23 above or such extension of time granted by the Exchange (the timeframes and extensions of time granted by the Exchange, if any, will individually or collectively, as the context may require, be referred to as "**Relevant Timeframes**").
- (2) A listed issuer which intends to request for the extension of time referred to in subparagraph (1) above must do so not later than 15 days before the expiry of the Relevant Timeframes, failing which the Exchange will not consider such application. The listed issuer must immediately announce to the Exchange any extension of time granted in relation to such application.
- (3) If a listed issuer becomes aware or has any reason to believe that it will not be able to issue its quarterly report, annual audited financial statements or annual report, as the case may be, (referred to either individually or collectively, as the context may require, as "**outstanding Financial Statements**") within the Relevant Timeframes, it must announce this to the Exchange immediately or in any event, not later than 3 market days before the expiry of the Relevant Timeframes.
- (4) The listed issuer must include the information contained in Part I of Appendix 9A in the announcement under subparagraph (3) above.
- (5) If a listed issuer fails to issue the outstanding Financial Statements within 5 market days after the expiry of the Relevant Timeframes (the last day of this 5 market day period is referred to as "**Suspension Deadline**"), in addition to any enforcement action that the Exchange may take, the Exchange shall suspend trading in the securities of such listed issuer. The suspension shall be effected on the next market day after the Suspension Deadline and will be uplifted on the market day following the issuance of the outstanding Financial Statements unless otherwise determined by the Exchange.
- (6) If a listed issuer fails to issue the outstanding Financial Statements within 6 months from the expiry of the Relevant Timeframes, in addition to any enforcement action that the Exchange may take, the Exchange shall commence de-listing procedures against such listed issuer.
- (7) For the purposes of this paragraph, "**issue**" means announcing to the Exchange or issuing to shareholders as provided under paragraph 9.22 or 9.23, as the case may be.

9.29 Memorandum of understanding

A listed issuer must immediately announce to the Exchange the status of any memorandum of understanding that has been entered into between the listed issuer and a third party and which has been previously announced, at least once every quarter or more regularly, upon the occurrence of a material change, whichever is the earlier.

PART L – CIRCULARS AND OTHER REQUIREMENTS**9.30 Draft circulars and other documents**

- (1) A listed issuer or offeror in an offer for sale of listed securities must submit to the Exchange for perusal, 1 draft copy of all circulars and other documents proposed to be sent to the holders of listed securities, within a reasonable time before printing together with a checklist showing compliance with the relevant parts of these Requirements.
- (2) Subparagraph (1) above does not apply to the following documents:
 - (a) an annual report;
 - (b) any document to be sent to holders of listed securities in relation to a take-over by or in respect of a listed issuer excluding circulars to be issued by a listed issuer, proposing to undertake or undertaking a take-over, to its securities holders pursuant to Chapter 10 of these Requirements;
 - (c) any document that is not prepared by the listed issuer or its advisers on its behalf;
 - (d) any circular to be issued by a listed issuer to its securities holders pursuant to paragraphs 10.11 and 10.14 of these Requirements, in relation to a transaction which will result in a significant change in the business direction or policy of the listed corporation and in relation to a qualifying acquisition proposed to be made by a SPAC; and
 - (e) such other document as prescribed by the Exchange subject to such requirements as may be imposed by the Exchange.
- (3) A listed issuer or offeror must not issue any of such documents referred to in subparagraph (1) above until the Exchange has confirmed in writing that it has no further comments on the documents.
- (4) Where an adviser is appointed by the listed issuer or offeror for the preparation and/or submission of the documents referred to in subparagraph (1) above to the Exchange, such adviser must also comply with subparagraphs (1) and (3) above.

[Cross reference: Practice Note 18]

9.31 Quality of draft documents

A person submitting to the Exchange a draft circular or other draft documents pursuant to paragraph 9.30 above must ensure that such documents are precise and complete. The Exchange reserves the right to return such documents which are incomplete or deemed unsatisfactory in the opinion of the Exchange.

9.32 Standard of disclosure for circulars

- (1) A listed issuer must ensure that any circular issued to the securities holders of the listed issuer -
 - (a) is factual, clear, unambiguous, accurate, succinct and contains all such information as securities holders and their advisers would reasonably require and reasonably expect to find in a circular of that nature, for the purpose of making an informed decision;
 - (b) is not false, misleading or deceptive;

-
- (c) is balanced and fair. Thus, the circular must avoid amongst others -
- (i) the omission of important unfavourable facts, or the slighting of such facts (e.g. by “burying” them at the end of a press release);
 - (ii) the presentation of favourable possibilities as certain, or as more probable than is actually the case;
 - (iii) the representation with respect to any future performance, occurrence or matter (including the doing of, or the refusing to do, any act) without adequate justification (supported by proper bases and assumptions) or any reasonable grounds for making of such representation;
 - (iv) the presentation of revenue or profit estimates, forecasts or projections without sufficient qualification or sufficient factual basis, or without review by the external auditors of the accounting bases and calculations, and assumptions. If any revenue or profit estimate, forecast or projection is released, it must be prepared carefully, with a reasonable factual basis and be stated realistically, with appropriate assumptions and qualifications, so as to ensure that it is properly understood, and the accounting bases and calculations of the estimate, forecast or projection and the assumptions thereto must be reviewed by the external auditors;
 - (v) negative statements phrased so as to create a positive implication; e.g. “The company cannot now predict whether the development will have a materially favourable effect on its earnings” (creating the implication that the effect will be favourable even if not materially favourable), or “The company expects that the developments will not have a materially favourable effect on earnings in the immediate future” (creating the implication that the development will eventually have a materially favourable effect); and
 - (vi) use of promotional jargon calculated to induce investment or create interest in the securities of the listed issuer rather than to inform;
- (d) avoids over-technical language, and is expressed to the extent possible in language comprehensible to the layman; and
- (e) explains, if the consequences or effects of the information on the listed issuer’s future prospects cannot be assessed, why this is so.
- (2) Where an adviser is appointed by the listed issuer for the preparation or submission of the circular for issuance to the holders of the listed securities, such adviser must also comply with subparagraph (1) above.
- (3) A listed issuer or its adviser does not commit a breach of subparagraphs (1) or (2) above, as the case may be, if such person proves that -
- (a) he had made all enquiries as were reasonable in the circumstances; and
 - (b) after making such enquiries, he had reasonable grounds to believe and did believe until the issue of the circular that the circular did fulfil the requirements of subparagraph (1) above.
- (4) Where any circular referred to in subparagraph (1) above has been issued and the person referred to in subparagraphs (1) or (2) above subsequently becomes aware that the circular may not fulfil the requirements of subparagraph (1) above, the person must immediately notify the Exchange of the same.

9.33 Issuance of circular or document

- (1) Where a listed issuer announces a corporate proposal (including a transaction) and pursuant to these Requirements a circular or document is required to be issued to its securities holders in relation to such corporate proposal -
- (a) the said listed issuer must submit the draft circular or document to the Exchange or issue the circular or document as the case may be, in accordance with these Requirements as soon as possible and in any event no later than 2 months from the date of the announcement or the date the last approval necessary for the corporate proposal is obtained from the relevant authority, whichever is the later; and
 - (b) where the draft circular or document is submitted to the Exchange pursuant to subparagraph (a) above, the circular or document must be issued immediately upon receipt of the Exchange's confirmation that it has no further comments and in any event no later than 14 market days after receipt of such confirmation.
- (2) The timeframe prescribed under subparagraph (1)(b) above does not apply to circulars or documents for any of the following purposes:
- (a) procurement of shareholder mandate in respect of recurrent related party transactions and share buy-backs which are to coincide with the annual general meeting;
 - (b) notification of maturity of securities;
 - (c) notification of share exchange, recall or reduction;
 - (d) notification of subdivision of shares; or
 - (e) such other corporate proposal or action as may be prescribed by the Exchange from time to time.

9.34 Documents for overseas securities holders

A listed issuer must forward all documents for overseas securities holders of listed issuers by airmail or any speedier form of transmission.

9.35 Copies of documents to be supplied to the Exchange

A listed issuer must give the Exchange ~~with~~ 15 copies or any such number as the Exchange may determine from time to time of -

- (a) all periodic and special reports, circulars, and all other documents released or issued by the listed issuer to the holders of any of the listed issuer's securities;
- (b) the annual audited financial statements together with the auditors' and directors' reports and the printed annual report of the listed issuer and all documents required by law to be annexed to such documents, as soon as issued; and
- (c) information on the annual general meeting proceedings where the information is additional to that contained in the annual report.

PART M - DISCLOSURE REQUIREMENTS FOR SPECIFIC LISTED ISSUERS**9.36 Mining, plantation and timber ~~companies~~corporations**

A listed issuer in the business of mining, plantation or timber, must immediately announce to the Exchange the production figures for each month not later than the end of the subsequent month.

PART M1 - INFRASTRUCTURE PROJECT CORPORATIONS**9.37 Immediate announcement by an infrastructure project corporation**

An infrastructure project corporation must immediately announce to the Exchange any substantial variance in the earnings and cash flow projections which may have an adverse impact on its earning prospects at any time during the period of construction of the infrastructure project and 3 years after operating pre-tax profits are generated.

9.38 Quarterly report of an infrastructure project corporation

An infrastructure project corporation must announce the quarterly progress reports on its infrastructure project not later than 2 months after the end of each quarter of a financial year.

PART M2 - CLOSED-END FUNDS**9.39 Notification of change in policies and objectives by a closed-end fund**

A closed-end fund must immediately announce to the Exchange any proposal to change its investment policies and objectives.

9.40 Quarterly report of a closed-end fund

- (1) A closed-end fund must announce to the Exchange a quarterly report pursuant to paragraph 9.22.
- (2) The closed-end fund must include in its quarterly report ~~:-~~
 - (a) the information set out in Part A of Appendix 9B, except for the information prescribed in Note 8 of Appendix 9B; and
 - (b) the additional information set out in Part B of Appendix 9B; and
 - (c) any other information as may be required by the Exchange.

9.41 Annual report of a closed-end fund

A closed-end fund must include in its annual report and accounts ~~:-~~

- (a) the information set out in Part A of Appendix 9C; and
- (b) the additional information set out in Part B of Appendix 9C.

9.42 Weekly disclosure by a closed-end fund

A closed-end fund must, in addition, ~~give announce to~~ the Exchange ~~for public release~~ its net asset value per share on a weekly basis.

PART M3 - REAL ESTATE INVESTMENT TRUSTS**9.43 Immediate announcements to the Exchange**

- (1) In addition to the requirements set out in this Chapter, a management company must immediately announce to the Exchange the following events:
- (a) any change in the control of the management company or the trustee;
 - (b) any proposed change in the general character or nature of the trust;
 - (c) any intention to renew, vary or terminate the trust;
 - (d) any change or proposed change of the trustee or management company;
 - (e) a valuation which has been carried out on the assets of the trust, stating whether the valuation is subject to the approval of the SC. A copy each of the valuation reports must be made available for inspection at the management company's office for a period of 3 months;
 - (f) any proposal which will result in the borrowings (including borrowings through issuance of debt securities) exceeding 50% of the total asset value of the fund and the reason for the proposal;
 - (g) any event which will significantly affect the underlying value of the assets of the trust;
 - (h) any change in the name of the management company or trustee;
 - (i) any change or proposed change in the rate of management fee or trustee fee;
 - (j) any material modification to the deed of trust;
 - (k) any material change to the investment objectives set out for the trust;
 - (l) any change in the composition of the investment committee;
 - (m) any acquisition or disposal of real estates, single-purpose ~~companies-corporations~~ or real estate-related assets, where the value of consideration is 25% or more of the fund's total asset value; ~~under~~
 - (n) any related party transaction.
- (2) For the purposes of subparagraph (1) above, the terms "**real estates**", "**single-purpose companies**", "**real estate-related assets**", "**total asset value**" and "**related party transaction**" have the same meanings given in the SC's Guidelines on Real Estate Investment Trusts.

9.44 Quarterly reports of a real estate investment trust

- (1) A management company of a real estate investment trust must announce to the Exchange an interim financial report of the real estate investment trust for each of the first three quarters of its financial year ("**REIT Quarterly Report**") immediately after the figures are available, but in any event, not later than 2 months after the quarter ends.
- (2) The management company need not comply with paragraph 9.22(2) of these Requirements in preparing the REIT Quarterly Report. Instead, the management company must ensure that the REIT Quarterly Report complies with the following provisions from Schedule B of the SC's

Guidelines on Real Estate Investment Trusts and include any other information as may be required by the Exchange:

- (a) Paragraphs 9 – 11 relating to manager's report with the exception of paragraphs 11(a), (b), (c), (h)(o) and (p); and
 - (b) Paragraphs 19 – 22 relating to financial statements.
- (3) Where there is a change in the financial year proposed by a management company, such management company must consult the Exchange as to the period to be covered by the REIT Quarterly Report.

9.45 Annual reports and distribution statements of a real estate investment trust

- (1) A management company must also issue annual reports that includes annual audited financial statements together with the auditors' and management company's reports of the real estate investment trust and forward them to the Exchange and unit holders within 2 months after the end of the period to which they relate.
- (2) A management company need not comply with paragraph 9.25(1) of these Requirements in preparing the annual report of the real estate investment trust. Instead, a management company must ensure that the contents of the annual report of the real estate investment trust comply with the requirements relating to annual reports of the fund as stipulated under the SC's Guidelines on Real Estate Investment Trusts,
- (3) A management company must forward every distribution statement to the unit holders and the Exchange accompanied by a report as to the state of the trust which includes the information in Appendix 9D.

PART M4 - EXCHANGE-TRADED FUNDS

9.46 Announcements to the Exchange

- (1) A management company of an exchange-traded fund must announce to the Exchange -
 - (a) the indicative optimum portfolio value (IOPV) per unit of the fund on a real-time basis, or within such time as may be allowed under the SC's ~~Guidelines on Exchange Traded Funds~~ Exchange-Traded Funds Guidelines;
 - (b) the net asset value (NAV) per unit of the fund on daily basis; and
 - (c) number of units in circulation on a monthly basis.
- (2) For the purpose of subparagraph (1) above, the terms "indicative optimum portfolio value" and "net asset value" have the meaning given under the SC's ~~Guidelines on Exchange Traded Funds~~ Exchange-Traded Funds Guidelines.

9.47 Immediate announcements to the Exchange

In addition to the requirements set out in this Chapter, a management company of an exchange-traded fund must immediately announce to the Exchange the following events:

- (a) any change or proposed change of the trustee or management company;
- (b) any change in the control of the management company or the trustee;
- (c) any change in the name of the management company or the trustee;

- (d) any change or proposed change in the rate of management fee or trustee fee;
- (e) any proposed change in the general character or nature of the fund;
- (f) any intention to renew, vary or terminate the fund, and the material developments of such proposal;
- (g) any intention to apply to the SC to increase the size of the fund;
- (h) any material modification to the deed of the fund;
- (i) any material change to the investment objectives set out for the fund;
- (j) any change or proposed change to the constituents and weightings of the index basket; or
- (k) any change in the methodology for compiling or calculating the index.

9.48 Quarterly reports of an exchange-traded fund

- (1) A management company must announce to the Exchange an interim financial report of the exchange-traded fund for each of the first three quarters of its financial year (“**ETF Quarterly Report**”) immediately after the figures are available, but in any event, not later than 2 months after the quarter ends.
- (2) The management company need not comply with paragraph 9.22(2) of these Requirements in preparing the ETF Quarterly Report. Instead, the management company must ensure that the ETF Quarterly Report complies with the following provisions from Schedule B of the ~~contains~~ manager’s report and financial statement as specified in the SC’s Guidelines on Exchange-Traded Funds Guidelines, and include any other information as may be required by the Exchange:
 - (a) Paragraphs 9 – 11 relating to manager’s report with the exception of paragraphs 11(a), (b), (c) and (m); and
 - (b) Paragraphs 19 – 20 relating to financial statements.
- (3) Where there is a change in the financial year proposed by a management company, such management company must consult the Exchange as to the period to be covered by the ETF Quarterly Report.

9.49 Annual reports of an exchange-traded fund

- (1) A management company must also issue annual reports that includes annual audited financial statements together with the auditors’ and management company’s reports of the exchange-traded fund and forward them to the Exchange and unit holders within 2 months after the end of the period to which they relate.
- (2) A management company must ensure that the contents of annual reports of the exchange-traded fund comply with the requirements relating to annual reports of the fund as stipulated under the SC’s Guidelines on Exchange-Traded Funds Exchange-Traded Funds Guidelines, instead of paragraph 9.25(1).

PART M5 - SPECIAL PURPOSE ACQUISITION COMPANIES

9.50 Notification of change in information

In addition to the requirements set out in this Chapter, a SPAC must immediately announce to the Exchange the following events:

- (a) any material change to the information disclosed in the prospectus including the change of custodian of its Trust Account or any change in the Permitted Investments;
- (b) upon the SPAC becoming aware that it will not be able to complete its qualifying acquisition within the period prescribed under the SC's Equity Guidelines. The SPAC must include in the announcement the reasons for not being able to do so; and
- (c) any change in the composition of the management team.

9.51 Reporting obligations

- (1) A SPAC need not comply with paragraph 9.22. Instead, ~~such a~~ the SPAC must announce to the Exchange its interim unaudited or audited financial report within 2 months after the close of the half year of the SPAC's financial year.
- (2) The SPAC must include the information set out in Appendix 9E in the said interim financial report.

[End of Chapter]

APPENDIX 9A**Part A****Contents of announcement in relation to the appointment of a director**

(paragraph 9.19(12))

- (a) The name, age, nationality, qualification and whether the position is an executive or non-executive one and whether such director is an independent director.
- (b) Working experience and occupation.
- (c) Any other directorship of public companies.
- (d) Any family relationship with any director and/or major shareholder of the listed issuer.
- (e) Any conflict of interests that he has with the listed issuer. ~~and~~
- (f) The details of any interest in the securities of the listed issuer or its subsidiaries.

Part B**Contents of announcement in relation to the appointment of a chief executive**

(paragraph 9.19(14))

- (a) The name, age, nationality and qualification.
- (b) Working experience.
- (c) Any other directorships of public companies.
- (d) Any family relationship with any director and/or major shareholder of the listed issuer.
- (e) Where the chief executive is not a director of the listed issuer, whether the appointee has any conflict of interests with the listed issuer or its subsidiaries. ~~and~~
- (f) The details of any interest in the securities of the listed issuer or its subsidiaries.

Part C**Contents of announcement in relation to winding-up proceedings**

(paragraph 9.19(19))

- (a) The date of the presentation of the winding-up petition and the date the winding-up petition was served on the listed issuer, its subsidiary or major associated company, as the case may be.
- (b) The particulars of the claim under the petition, including the amount claimed for under the petition and the interest rate.
- (c) The details of the default or circumstances leading to the filing of the winding-up petition against the listed issuer, its subsidiary or major associated company, as the case may be.

**Appendix 9A
Contents of announcement**

-
- (d) ~~w~~Where winding-up is commenced against a subsidiary, a confirmation as to whether the subsidiary is a major subsidiary.;
 - (e) ~~w~~Where winding-up is commenced against a subsidiary or major associated company, the total cost of investment in such subsidiary or major associated company.;
 - (f) ~~t~~The financial and operational impact of the winding-up proceedings on the group.;
 - (g) ~~t~~The expected losses, if any arising from the winding-up proceedings.;
 - (h) ~~t~~The steps taken and proposed to be taken by the listed issuer in respect of the winding-up proceedings.

Part D**Contents of announcement in relation to the appointment of a receiver, manager or receiver and manager or person of similar capacity**

(paragraph 9.19(20))

- (a) The date of appointment.;
- (b) ~~t~~The details of the ~~company corporation~~ which is under the receiver, manager or receiver and manager or other person of similar capacity.;
- (c) ~~w~~Where the appointment is in respect of a subsidiary, a confirmation as to whether the subsidiary is a major subsidiary.;
- (d) ~~t~~The net book value of the affected assets.;
- (e) ~~t~~The details of the events leading to the appointment of the receiver, manager or receiver and manager or other person of similar capacity.;
- (f) ~~t~~The financial and operational impact of the aforesaid appointment on the group, if any.;
- (g) ~~t~~The expected losses, if any, arising from the aforesaid appointment.;
- (h) ~~t~~The steps taken or proposed to be taken by the listed issuer in respect of the ~~aforesaidabove~~ appointment.

Part E**Contents of announcement in relation to the appointment of a special administrator or liquidator (which includes a provisional liquidator)**

(paragraph 9.19(20))

- (a) The date of appointment.;
- (b) ~~t~~The particulars of the special administrator or liquidator.;
- (c) ~~t~~The details of the events leading to the appointment of the special administrator or liquidator.;
- (d) ~~t~~The terms of reference of the special administrator or liquidator.;

-
- (e) The financial and operational impact of the aforesaid appointment on the group, if any.
 - (f) The effect of the appointment on the business operations of the listed issuer.
 - (g) The steps taken or proposed to be taken by the listed issuer in respect of the appointment of the special administrator or liquidator. ~~and~~
 - (h) The role of the board of directors in light of the appointment of the special administrator or liquidator.

Part F

Contents of announcement in relation to a restraining order

(paragraph 9.19(21))

- (a) The date of commencement and duration of the court order.
- (b) The details of the events leading to the grant of the court order.
- (c) The financial and operational impact on the group, if any. ~~and~~
- (d) The details of the proposed scheme.

Part G

Contents of announcement in relation to a depository receipt

(paragraph 9.19(42))

- (a) The number and names of the custodians holding the securities for which the depository receipts are issued.
- (b) The total number and percentage of the securities for which the depository receipts are issued against the issued and paid-up capital of the listed issuer and a breakdown of the same in respect of the securities held by each custodian.
- (c) The name of the depository bank.
- (d) The stock market in which the depository receipts are traded (if applicable). ~~and~~
- (e) Any other material term.

Part H

Contents of announcement in relation to valuation on non-current assets

(paragraph 9.19(46))

- (a) The purpose of the valuation.
- (b) The revaluation surplus or deficit as the case may be.
- (c) The effect of the revaluation surplus or deficit on the net assets per share of the group.
- (d) The name of the valuers.

- (e) ~~the~~ The date of valuation; ~~and~~
- (f) ~~the~~ The value placed on the asset by the valuer.

Part I**Information on suspension in view of delay in the issuance of quarterly reports, annual audited financial statements or annual report**

(paragraph 9.28(4))

- (a) The reasons for failing to issue the outstanding Financial Statements within the Relevant Timeframe; ~~;~~
- (b) A statement that the suspension of trading will be effected on the next market day after the expiry of 5 market days from the Relevant Timeframe; ~~;~~
- (c) The date suspension of trading will be effected; ~~;~~
- (d) The tentative timeline in respect of the steps taken or proposed to be taken to issue the outstanding Financial Statements, and the status of compliance with such timeline; ~~and~~
- (e) The expected date of issuance of the outstanding Financial Statements.

Part J**Contents of announcement in relation to a take-over offer**

(paragraph 9.19(48))

- (1) In relation to a take-over offer, whether it is the offeror's intention to maintain the listed issuer's listing status; ~~and~~
- (2) A statement containing either (a) or (b) below.
 - (a) If the offeror's intention is to maintain the listed issuer's listing status; ~~;~~
 - (i) the percentage of public shareholding spread;
 - (ii) a statement that the trading of the securities of the listed issuer will be suspended immediately upon the expiry of 30 market days from the date of immediate announcement by the listed issuer. The suspension will only be uplifted by the Exchange upon the listed issuer's full compliance with the public shareholding spread requirements under paragraph 8.02(1) or as may be determined by the Exchange;
 - (iii) the steps taken or proposed to be taken by the listed issuer (if any) to increase its public shareholding spread to above 10% before the date suspension is to be effected;
 - (iv) an explanation of the rectification plan (if any);
 - (v) the tentative timeline for the steps referred to in subparagraph (iii) above and the rectification plan; ~~and~~

Appendix 9A
Contents of announcement

- (vi) where neither the steps referred to in subparagraph (iii) above nor a rectification plan have been formulated or if no endeavours have been taken to formulate such steps or rectification plan, an appropriate negative statement to such effect; and
- (b) If the offeror's intention is to de-list the listed issuer, that trading in the listed issuer's securities will be suspended immediately upon the expiry of 5 market days from the date of the immediate announcement.

[End of Appendix]

APPENDIX 9B**Part A****Quarterly report**

(paragraphs 9.22(2) and 9.40)

Notes

1. A review of the performance of the corporation and its principal subsidiaries, setting out material factors affecting the earnings and/or revenue of the corporation and the group for the current quarter and financial year-to-date.
2. An explanatory comment on any material change in the profit before taxation for the quarter reported on as compared with the immediate preceding quarter.
3. A commentary on the following:
 - (a) the prospects, including the factors that are likely to influence the corporation's prospects for the remaining period to the end of the financial year or the next financial year if the reporting period is the last quarter; and
 - (b) the corporation's progress to achieve the revenue or profit estimate, forecast, projection or internal targets in the remaining period to the end of the financial year and the forecast period which was previously announced or disclosed in a public document and steps taken or proposed to be taken to achieve the revenue or profit estimate, forecast, projection or internal targets.
4. A statement of the board of directors' opinion as to whether the revenue or profit estimate, forecast, projection or internal targets in the remaining period to the end of the financial year and the forecast period which was previously announced or disclosed in a public document are likely to be achieved.
5. An explanatory note for any (only applicable to the final quarter for ~~companies-corporations~~ which have previously announced or disclosed a profit forecast or profit guarantee in a public document) -
 - (a) variance of actual profit after tax and minority interest and the forecast profit after tax and minority interest (where the variance exceeds 10%); and
 - (b) shortfall in the profit guarantee received by the ~~company-corporation~~ (if any) and steps taken to recover the shortfall.
6. A breakdown of tax charge and an explanation of the variance between the effective and statutory tax rate for the current quarter and financial year-to-date.
7. The amount of profits/(losses) on any sale of unquoted investments and/or properties respectively for the current quarter and financial year-to-date.

8. The following particulars of any purchase or disposal of quoted securities other than securities in existing subsidiaries and associated companies by all corporations except closed-end funds, a ~~company-corporation~~ whose activities are regulated by any written law relating to banking, finance ~~companies-corporations~~ or insurance and are subject to supervision by Bank Negara Malaysia, Participating Organisations and such other ~~companies-corporations~~ as may be exempted by the Exchange:

- (a) total purchase consideration and sale proceeds of quoted securities for the current quarter and financial year-to-date and profit/loss arising from the same;
- (b) investments in quoted securities as at the reporting period -
 - (i) at cost;
 - (ii) at carrying value/book value; and
 - (iii) at market value.

9. (a) The status of corporate proposals announced but not completed at the latest practicable date which must not be earlier than 7 days from the date of issue of the quarterly report.

(b) Where applicable, a brief explanation of the status of utilisation of proceeds raised from any corporate proposal, which must include the information prescribed in the following table:

Purpose	Proposed Utilisation	Actual Utilisation	Intended Timeframe for Utilisation	Deviation	Explanations
	RM'000	RM'000		Amount RM'000	%
(i)					
(ii)					
(iii)					
(iv)					
(v)					
Total					

10. The group borrowings and debt securities as at the end of the reporting period -

- (a) whether secured or unsecured, and a breakdown between secured and unsecured, if applicable;
- (b) breakdown between short term and long term borrowings; and
- (c) whether denominated in foreign currency, and a breakdown of the debt/borrowings in each currency, if applicable.

11. A summary of off balance sheet financial instruments by type and maturity profile at the latest practicable date which must not be earlier than 7 days from the date of issue of the quarterly report, including the following information:

-
- (a) the face or contract amount (or notional principal amount if there is no face or contract amount); and
- (b) the nature and terms, including at minimum, a discussion of -
- (i) the credit and market risk of those instruments;
 - (ii) the cash requirement of those instruments; and
 - (iii) the related accounting policies.
12. Changes in material litigation (including status of any pending material litigation) since the last annual balance sheet date which must be made up to a date not earlier than 7 days from the date of issue of the quarterly report.
13. Dividend: To be completed if a decision regarding dividend has been made. (State whether dividend amount is before tax, net of tax or tax exempt and if before tax or net of tax, state the tax rate) -
- (a)
 - (i) an interim/final ordinary dividend has/has not been declared/ recommended;
 - (ii) the amount per share.....sen;
 - (iii) the previous corresponding period.....sen;
 - (iv) the date payable.....; and
 - (v) in respect of deposited securities, entitlement to dividends will be determined on the basis of the record of depositors as atdd/mm/yyyy; and
 - (b) the total dividend for the current financial year..... sen.
14. To disclose the following in respect of earnings per share: -
- (a) the amount used as the numerator in calculating basic and diluted earnings per share and a reconciliation of those amounts to the net profit or loss for the reporting period; and
 - (b) the weighted average number of ordinary shares used as the denominator in calculating basic and diluted earnings per share, and a reconciliation of these denominators to each other.
15. Where the audit report of the corporation's preceding annual financial statements was qualified, disclosure of the qualification and the current status of the matter(s) giving rise to the qualification for the current quarter and financial year to date.

Part B**Contents of quarterly report of closed-end funds**

(paragraph 9.40)

- (1) The net asset value per share calculated in accordance with the SC's Guidelines for Public Offerings of Securities of Closed-end Funds. ~~;~~ and

- (2) The extent to which the closed-end fund has invested in -
- (a) securities listed on other stock exchanges;
 - (b) investments in other investment vehicles;
 - (c) investment in securities of unlisted ~~companies~~ corporations; and
 - (d) derivatives.

[_End of Appendix]

APPENDIX 9C**Part A****Contents of annual report**
(paragraphs 9.25 and 9.41)

- (1) The address, telephone and facsimile numbers of the registered office.†
- (2) The address, telephone and facsimile numbers of each office at which a register of securities is kept.†
- (3) The particulars of each director in the listed issuer including the following information:
 - (a) the name, age, nationality, qualification and whether the position is an executive or non-executive one and whether such director is an independent director;
 - (b) working experience and occupation;
 - (c) the date he was first appointed to the board;
 - (d) the details of any board committee to which he belongs;
 - (e) any other directorship of public companies;
 - (f) any family relationship with any director and/or major shareholder of the listed issuer;
 - (g) any conflict of interests that he has with the listed issuer;
 - (h) the list of convictions for offences within the past 10 years other than traffic offences, if any; and
 - (i) the number of board meetings attended in the financial year.†
- (4) Name of the chief executive and where the chief executive is not a director, the following particulars:
 - (a) the name, age, nationality and qualification;
 - (b) working experience;
 - (c) the date he was first appointed to the listed issuer;
 - (d) the details of any interest in the securities of the listed issuer or its subsidiaries;
 - (e) any directorship of public companies;
 - (f) any family relationship with any director and/or substantial shareholder of the listed issuer;
 - (g) any conflict of interests that he has with the listed issuer; and
 - (h) the list of convictions for offences within the past 10 years other than traffic offences, if any.†

-
- (5) The name of the company secretary.†
 - (6) The audit committee report in respect of the financial year required under paragraph 15.15.†
 - (7) The Chairman's statement which represents the collective view of the board of directors setting out a balanced summary which includes the following:
 - (a) a brief description of the industry trend and development;
 - (b) a discussion and analysis of the group's performance during the year and the material factors underlying its results and financial position. It should emphasise trends and identify significant events or transactions during the year under review; and
 - (c) the prospects of the listed issuer.†
 - (8) A statement relating to corporate governance in respect of the financial year required under paragraph 15.25.†
 - (9) A responsibility statement in respect of the annual audited financial statements required under paragraph 15.26(a).†
 - (10) A statement on internal control in respect of the financial year required under paragraph 15.26(b).†
 - (11) The remuneration of directors of the listed issuer for the financial year and in the following manner:
 - (a) the aggregate remuneration of directors with categorisation into appropriate components (e.g. directors' fees, salaries, percentages, bonuses, commission, compensation for loss of office, benefits in kind based on an estimated money value) distinguishing between executive and non-executive directors; and
 - (b) the number of directors whose remuneration falls in each successive band of RM50,000 distinguishing between executive and non-executive directors.†
 - (12) The total number of board meetings held during the financial year.†
 - (13) Where applicable, a brief explanation of the status of utilisation of proceeds raised from any corporate proposal.†
 - (14) The information required under paragraph 12.23 in respect of share buy-backs for the financial year.†
 - (15) The amount of options or convertible securities issued by the listed issuer which are exercised during the financial year.†
 - (16) A brief explanation on the depository receipt programme sponsored by the listed issuer, including the following:
 - (a) the number and names of the custodians holding the securities for which the depository receipts are issued;

-
- (b) the total number and percentage of the securities for which the depository receipts are issued against its issued and paid-up capital and a breakdown of the same in respect of the securities held by each custodian;
 - (c) the name of the depository bank; and
 - (d) the stock market in which the depository receipts are traded (if applicable).⁵
- (17) Particulars of all sanctions and/or penalties imposed on the listed issuer and its subsidiaries, directors or management by the relevant regulatory bodies.⁵
- (18) The amount of non-audit fees incurred for services rendered to the listed issuer or its subsidiaries for the financial year by the listed issuer's auditors, or a firm or corporation affiliated to the auditors' firm.⁵
- (19) Where the results for the financial year differ by 10% or more from any profit estimate, forecast or projection or unaudited results previously made or released by the listed issuer for that period, an explanation of the difference and a reconciliation of the difference.⁵
- (20) Any shortfall in the profit guarantee received by the listed issuer in the financial year as compared with the profit guarantee (if any) and steps taken to recover the shortfall.⁵
- (21) Particulars of material contracts of the listed issuer and its subsidiaries, involving directors' and major shareholders' interests, either still subsisting at the end of the financial year or, if not then subsisting, entered into since the end of the previous financial year, providing the following particulars in respect of each such contract:
- (a) the date;
 - (b) the parties;
 - (c) the general nature;
 - (d) the consideration passing to or from the listed issuer or any other corporation in the group;
 - (e) the mode of satisfaction of the consideration; and
 - (f) the relationship between the director or major shareholder and the contracting party (if the director or major shareholder is not the contracting party).
- If no such material contract has been entered into, a statement to that effect.⁵
- (22) Where the above contract relates to a loan, the following particulars in respect of each loan:
- (a) the names of the lender and the borrower;
 - (b) the relationship between the borrower and the director or major shareholder (if the director or the major shareholder is not the borrower);
 - (c) the purpose of the loan;
 - (d) the amount of the loan;

- (e) the interest rate;
 - (f) the terms as to payment of interest and repayment of principal; and
 - (g) the security provided.†
- (23) A statement indicating the date of such statement and setting out -
- (a) the names of the substantial shareholders (excluding bare trustees) and their direct and deemed interests stating the number and percentage of shares in which they have an interest as shown in the register of substantial shareholders of the listed issuer;
 - (b) a statement showing the direct and deemed interests of each director (including number and percentage) in the listed issuer, or in a related corporation, appearing in the register maintained under section 134 of the Companies Act 1965;
 - (c) the number of holders of each class of equity securities and any convertible securities and the voting rights attaching to each class;
 - (d) a distribution schedule of each class of equity securities and any convertible securities setting out the number of holders and percentage in the following categories:

No. of Holders	Holdings	Total Holdings	%
	less than 100		
	100 to 1,000 shares		
	1,001 to 10,000 shares		
	10,001 to 100,000 shares		
	100,001 to less than 5% of issued shares		
	5% and above of issued shares		
—			100%

- (e) the names of the 30 securities account holders having the largest number of securities from each class of equity securities and convertible securities according to the Record of Depositors (without aggregating the securities from different securities accounts belonging to the same person) and the number and percentage of equity securities and convertible securities of each class held. In the case of securities account holders which are authorised nominees as defined under the Securities Industry (Central Depositories) Act 1991, information in the account qualifier field of the securities account must also be stated.†
- (24) A statement regarding the revaluation policy on landed properties in respect of the financial year.†
- (25) Particulars of each property of the listed issuer or its subsidiaries which net book value is 5% or more of the consolidated total assets of the listed issuer as at the end of the financial year (“**material properties**”). In the event the number of the material properties is less than 10, particulars of the top 10 properties in terms of highest net book value (inclusive of the material properties) as at the end of the financial year. Particulars of such properties to be set out as follows as at the end of the financial year:

-
- (a) the address of each property;
- (b) in respect of each property -
- (i) a brief description (e.g. land or buildings, approximate areas, etc.);
 - (ii) the existing use (e.g. shops, offices, factories, residential, etc.);
 - (iii) the tenure (i.e. freehold, or leasehold and if leasehold, the date of expiry of the lease);
 - (iv) the approximate age of the buildings;
 - (v) the net book value; and
 - (vi) where revaluation has been carried out, the date of last revaluation and if none, the date of acquisition.
- (26) A statement by the audit committee in relation to the allocation of options pursuant to a share scheme for employees as required under paragraph 8.17;
- (27) A breakdown of the options offered to and exercised (if any) by non-executive directors pursuant to a share scheme for employees in respect of the financial year in tabular form as follows:
- | Name of director | Amount of options offered | Amount | of | options exercised |
|------------------|---------------------------|--------|----|-------------------|
| 1. | | | | |
| 2. | | | | |
| 3. | | | | |
| Total | | | | |
- (28) A statement by the board of directors containing a brief description on the type of training that the directors have attended for the financial year. Where any of the directors have not attended any training during the financial year, to state the reasons for each director.
- (29) A description of the corporate social responsibility activities or practices undertaken by the listed issuer and its subsidiaries or if there are none, a statement to that effect and
- (30) A statement relating to the internal audit function of the listed issuer, i.e. whether the internal audit function is performed in-house or is outsourced and the costs incurred for the internal audit function in respect of the financial year.

Part B

Contents of annual reports and accounts of closed-end funds

(paragraph 9.41)

- (1) A detailed statement of its investment objectives and policies and the manner in which those policies have been carried into effect (where applicable);

-
- (2) The gross revenue of the closed-end fund, to be divided separately to show at least the interest, dividends, profit/loss on the sale of investments and any item of revenue amounting to 5% or more of the gross revenue.;
 - (3) The initial service charges, management fees or any other fees paid to the Managers to be shown separately under gross expenses of the closed-end fund.;
 - (4) Generally, a disclosure of the composition of the investment portfolio of the closed-end fund, giving separately in respect of all investments -
 - (a) a reasonable description of the business;
 - (b) the number of securities owned;
 - (c) the costs; and
 - (d) if unlisted, the fair value, as agreed by the Managers and the board of directors of the closed-end fund and if listed, the market value of the investment.;
 - (5) With respect to all unlisted investments and all other investments with a value exceeding 5% of the closed-end fund's gross assets, in addition, the following:
 - (a) the dividends or other income received during the year from such investments (indicating any abnormal dividends);
 - (b) the relevant performance ratios; and
 - (c) the net assets attributable to the investment.;
 - (6) An analysis of any provision for diminution in value of investments, naming the investments against which provision has been made and stating for each investment -
 - (a) the costs;
 - (b) the provisions made; and
 - (c) the book value.;
 - (7) An analysis of realised and unrealised surpluses, stating separately profits and losses as between listed and unlisted investments.;
 - (8) The total number of transactions in securities entered into during the reporting period, together with the total brokerage paid or accrued during the reporting period.;
 - (9) The number of securities (if any) held by the Managers and family members of Managers (where applicable) or by other funds managed by the Managers, at the balance sheet date of the accounts.;
 - (10) Sales and purchases of investments into and from the closed-end fund, where the Managers acted as principals.

[-End of Appendix]

Appendix 9D
Contents of distribution statements of real estate investment trust

APPENDIX 9D

Contents of distribution statements of real estate investment trust

(paragraph 9.45(3))

- (1) The total gross and net income per unit for the period before charging management fees.
- (2) The net amount per unit (after allowing for charges and adjustments) recommended to be distributed to unit holders out of profits or reserves, together with the gross equivalent attributable to the distribution period.
- (3) The amount to be carried to reserves.

[End of Appendix]

APPENDIX 9E**Contents of half yearly report in relation to a special purpose acquisition company**
(paragraph 9.51)

- (1) General description of a SPAC's operating expenses (including the management team's remuneration, if any) and the total amounts that have been spent;
- (2) Detailed description, analysis and discussion on the top 5 highest amount of operating expenses.
- (3) A statement of whether there is any abnormal circumstance that has affected or will affect the business and financial position of the SPAC.
- (4) Commentary from the board of directors on the direction and progress of the qualifying acquisition, including any change to the objective, strategy, status and capital of the SPAC.
- (5) In relation to the proceeds kept in the Trust Account, the composition of the investments, SPACs investment strategy, market and credit risks for such investment.

[_End of Appendix]

CHAPTER 10 TRANSACTIONS**PART A - GENERAL****10.01 Introduction**

This Chapter sets out the requirements that must be complied with in respect of transactions entered into by a listed issuer or its subsidiaries.

PART B - DEFINITIONS**10.02 Definitions**

For the purpose of this Chapter, unless the context otherwise requires -

- (a) **“acquisition or disposal of assets”** includes an option to acquire or dispose of assets;
- (b) **“asset”** means all types of assets including securities and, business undertakings;
- (c) **“director”** has the meaning given in section 2(1) of the CMSA and includes any person who is or was within the preceding 6 months of the date on which the terms of the transaction were agreed upon -
 - (i) a director of the listed issuer, its subsidiary or holding company; or
 - (ii) a chief executive of the listed issuer, its subsidiary or holding company; ~~or~~ and
 - (iii) in relation to a SPAC, a member of the SPAC’s management team;
- (d) **“financial assistance”** includes -
 - (i) lending or advancing of money;
 - (ii) guaranteeing, indemnifying or providing collateral for a debt; or
 - (iii) forgiving a debt, releasing or neglecting to enforce a financial obligation of another, or assuming the financial obligations of another;
- (e) **“joint venture”** means a contractual arrangement between 2 or more parties to undertake a specific business project subject to joint control in which the parties meet the costs of the project and receive a share of any resulting output;
- (f) **“major shareholder”** includes any person who is or was within the preceding 6 months of the date on which the terms of the transaction were agreed upon, a major shareholder of the listed issuer as defined under paragraph 1.01 or any other ~~company~~ corporation which is its subsidiary or holding company;
- (g) **“percentage ratios”** means the figures, expressed as a percentage, resulting from each of the following calculations:
 - (i) the value of the assets which are the subject matter of the transaction, compared with the net assets of the listed issuer;

- (ii) net profits (after deducting all charges and taxation and excluding extraordinary items) attributable to the assets which are the subject matter of the transaction, compared with the net profits of the listed issuer;
- (iii) the aggregate value of the consideration given or received in relation to the transaction, compared with the net assets of the listed issuer;
- (iv) the equity share capital issued by the listed issuer as consideration for an acquisition, compared with the equity share capital previously in issue (excluding treasury shares);
- (v) the aggregate value of the consideration given or received in relation to the transaction, compared with the market value of all the ordinary shares of the listed issuer (excluding treasury shares);
- (vi) the total assets which are the subject matter of the transaction compared with the total assets of the listed issuer;
- (vii) in respect of joint ventures, business transactions or arrangements, the total project cost attributable to the listed issuer compared with the total assets of the listed issuer or in the case where a joint venture ~~company~~ corporation is incorporated as a result of the joint venture, the total equity participation of the listed issuer in the joint venture ~~corporation~~ company (based on the eventual issued capital of the joint venture ~~company~~ corporation) compared with the net assets of the listed issuer. The value of the transaction should include shareholders' loans and guarantees to be given by the listed issuer; or
- (viii) the aggregate original cost of investment of the subject matter of the transaction divided by the net assets of the listed issuer, in the case of a disposal and where the acquisition of the subject matter took place within last 5 years;

(h) “property development corporation” means a corporation whose core business is in –

(i) development or redevelopment of real estate; or

(ii) real estate with development potential,

and includes those rights to develop pursuant to a joint venture agreement, privatisation agreement or some other forms of joint arrangement;

(i) “property investment corporation” means a corporation whose core business is in –

(AA) the holding of landed or strata properties in the commercial, residential, industrial or agricultural sector (collectively referred to as “investment properties”) for letting and retention as investments; or

(BB) the purchase of investment properties for subsequent sale;

(h*j*) **“Recurrent Related Party Transaction”** means a related party transaction which is recurrent, of a revenue or trading nature and which is necessary for day-to-day operations of a listed issuer or its subsidiaries;

(h*k*) **“related party transaction”** means a transaction entered into by the listed issuer or its subsidiaries which involves the interest, direct or indirect, of a related party;

- (j) **“transaction”**, in relation to -
- (i) Part D of this Chapter, means the acquisition or disposal of assets by a listed issuer or its subsidiaries but excludes transactions of a revenue nature in the ordinary course of business;
 - (ii) Part E of this Chapter, includes -
 - (aa) the acquisition, disposal or leasing of assets;
 - (bb) the establishment of joint ventures;
 - (cc) the provision of financial assistance;
 - (dd) the provision or receipt of services; or
 - (ee) any business transaction or arrangement entered into, by a listed issuer or its subsidiaries; and
 - (iii) Parts D and E of this Chapter, excludes transactions entered into between a listed issuer (or any of its wholly-owned subsidiaries) and its wholly-owned subsidiary;
- (km) **“value of the consideration”** includes any liability to be assumed; and
- (ln) **“very substantial transaction”** means a disposal or acquisition of an asset where any of the percentage ratios is 100% or more, except an acquisition which will result in a significant change in the business direction or policy of a listed corporation.

PART C - VALUATION AND INFORMATION

10.03 Basis of valuation

- (1) For the purpose of determining the value of the assets referred to in paragraph 10.02(g)(i), the following applies:
- (a) in an acquisition of equity interest in a corporation which would not result in such equity interest being accounted for using the equity method, the value is to be assessed by reference to the cost of investment;
 - (b) in an acquisition of equity interest in a corporation which would result in -
 - (i) such equity interest being accounted for using the equity method; or
 - (ii) such corporation being consolidated into the group accounts (**“consolidation”**),
the value is to be assessed by reference to the book value of the net assets represented by such equity interest;
 - (c) in a disposal of equity interest in a corporation where before the disposal such equity interest was not accounted for using the equity method, the value is to be assessed by reference to the carrying amount of the investment;

-
- (d) in a disposal of equity interest in a corporation where before the disposal -
- (i) such equity interest was accounted for using the equity method; or
 - (ii) such corporation was included in consolidation,
- the value is to be assessed by reference to the book value of the net assets represented by such equity interest; or
- (e) in any acquisition of assets other than equity interest, the value of such assets is to be assessed by reference to the consideration. In the case of any disposal of assets other than equity interest, the value of such assets must be assessed by the consideration or the net book value of those assets, whichever is the greater.
- (2) For the purposes of determining the net profits attributable to the assets referred to in paragraph 10.02(g)(ii) in relation to -
- (a) an acquisition of equity interest in a corporation which would not result in such equity interest being accounted for using the equity method, the net profits are to be assessed by reference to the dividend income derived from such investment based on the last financial year end of such corporation; and
 - (b) a disposal of equity interest of a corporation where, before the disposal such equity interest was not accounted for using the equity method, the net profits are to be assessed by reference to the dividend income derived from such investment based on the last financial year end of such corporation.
- (3) The market value of the equity share capital of the corporation will be determined as the weighted average market price for the equity share capital for the 5 market days before the date on which the terms of the transaction were agreed upon.
- (4) For the purpose of computation of indicators of materiality (including the percentage ratios) in this Chapter, the following applies:
- (a) the figures used must, in the case of total assets, net assets, net book value of assets and net profits, be figures shown in the latest published or announced audited financial statements of the listed issuer or audited consolidated financial statements of the listed issuer, if the listed issuer has subsidiaries;
 - (b) the total assets, net assets and net book value of assets may be adjusted to take into account subsequent completed transactions in respect of which adequate information has already been issued to shareholders and where the adjustments have been reviewed by the listed issuer's external auditors and a copy of the external auditors' review report is furnished to the Exchange;
 - (c) the listed issuer may use the total assets, net assets, net book value of assets included in the balance sheet in its latest published or announced interim financial report provided that the report has been reviewed by the listed issuer's external auditors and a copy of the external auditors' review report is furnished to the Exchange;
 - (d) the listed issuer may use the net profits based on the unaudited 12 months results provided that the results have been reviewed by the listed issuer's external auditors and a copy of the external auditors' review report is furnished to the Exchange; and
 - (e) the figures used must, in the case of cost of investment or carrying amount of the investment referred to in subparagraph (1) above, be based on -

-
- (i) the latest published or announced audited financial statements of the listed issuer or audited consolidated financial statements of the listed issuer, if the listed issuer has subsidiaries; or
 - (ii) the latest published or announced interim financial report of the listed issuer provided that the report has been reviewed by the listed issuer's external auditors and a copy of the external auditors' review report is furnished to the Exchange.
 - (5) In the case of an acquisition or disposal by the grant or exercise of an option, the consideration for the acquisition or disposal is the total of the issue price of the option and its exercise price.
 - (6) If deferred consideration is or may be payable or receivable by a listed issuer or its subsidiary in the future, the consideration to be taken into account is the maximum total consideration payable or receivable under the transaction.
 - (7) In circumstances where any one of the percentage ratios produces an anomalous result or where the percentage ratios are inappropriate to the sphere of the activity of the listed issuer, or for any other reason that the Exchange deems fit, the Exchange may -
 - (a) disregard the results or percentage ratio; and/or
 - (b) substitute or apply other relevant indicators of size.
 - (8) The calculation set out in subparagraph 10.02(g)(v) is only applicable in respect of -
 - (a) transactions involving consideration in the form of listed equity shares; or
 - (b) transactions where all the other percentage ratios produce anomalous results or are inapplicable.
 - (9) In relation to any acquisition or disposal of equity interest in a corporation, the calculation set out in subparagraph 10.02(g)(vi) is only applicable where -
 - (a) the acquisition would result in such corporation being included in consolidation; or
 - (b) before the disposal, such corporation was included in consolidation.
 - (10) For the purposes of this paragraph, unless the context otherwise requires, the following words or expressions have the meanings given under the approved accounting standards of the Malaysian Accounting Standards Board-:
 - (a) equity method;
 - (b) carrying amount; and
 - (c) consolidation.

10.04 Valuation

- (1) A listed issuer must ensure that a valuation is conducted where -:
 - (a) a transaction involves an acquisition or disposal of any real estate or any corporation which owns real estate; and
 - (b) any one of the percentage ratios of the transaction is -

- (i) 25% or more, for a transaction falling under Part D; or
 - (ii) 5% or more, for a related party transaction falling under Part E.
- (2) For the purposes of subparagraph (1) above, a valuation is required for an acquisition or disposal of a corporation which owns real estate –
- (a) if the corporation is a property development or property investment corporation, the valuation must be conducted on all material real estate; and
 - (b) if the corporation is not a property development or property investment corporation, a valuation is only required if the real estate is to be revalued or has been revalued and the revalued amount is used, whether wholly or partly, as the basis in determining the purchase or disposal consideration.
- (23) Where a valuation is required under subparagraphs (1) and (2) above, the listed issuer must –
- (a) submit to the Exchange 2 copies of the valuation report on the real estate concerned and a copy of the valuer's undertaking letter in the form of Appendix 6D immediately after the listed issuer announces the transaction (if available) or as soon as the valuation report is ready. In any event, the listed issuer must submit the valuation report together with the valuer's undertaking letter to the Exchange at least 1 month before it submits its draft circular in relation to the transaction to the Exchange; and
 - (b) ensure that the date of valuation which forms the basis of the valuation certificate included in the circular is not more than 6 months before the date of the circular issued to shareholders.
- (34) A listed issuer and its valuer must ensure that the valuation report submitted pursuant to subparagraph (23) above complies with these Requirements and the SC's Asset Valuation Guidelines.
- (45) If the listed issuer or the valuer becomes aware of any circumstance or significant change which has or will have material effect on the content, validity or accuracy of its valuation report before the date of issuance of the circular, the valuer and the listed issuer must cause the valuation report to be updated. If the listed issuer fails to do so, the valuer must withdraw its consent to the inclusion of the valuation report in the circular.
- (56) Notwithstanding subparagraphs (1), and (2) and (3) above, the Exchange may at its discretion and whenever it deems appropriate, at the cost of the listed issuer –
- (a) obtain a second opinion on the valuation report submitted by the listed issuer from another valuer appointed by the Exchange; or
 - (b) require a listed issuer to conduct a valuation on the asset proposed to be acquired or disposed in respect of any transaction other than the transaction referred to in subparagraph (1) and (2) above,
- (67) A listed issuer and its valuer must comply with the instruction, directive or condition imposed by the Exchange and within such timeframe as may be specified by the Exchange.
- (78) The Exchange may refer any valuation report received by the Exchange to the SC for review. The listed issuer and its valuer must provide the Exchange or the SC on a timely basis, any information or assistance required in relation to the valuation report.

(9) For the purposes of subparagraphs (3)(a), (4), (5) and (8) above, a "valuation report" includes a valuation certificate.

PART D - ACQUISITIONS AND DISPOSALS

10.05 Requirements for transactions with percentage ratio below 5%

- (1) Subject to paragraph 10.08(1), where all the percentage ratios of a transaction are less than 5% and the consideration is satisfied in cash or unquoted securities, no announcement of the transaction to the Exchange is required.
- (2) If the listed issuer wishes to voluntarily announce the transaction to the Exchange, the listed issuer must include -
 - (a) the details of the consideration;
 - (b) the particulars of the transaction; and
 - (c) a statement that the directors, major shareholders or person connected with them have no interest, direct or indirect, in the transaction.
- (3) Where the consideration for the transaction is satisfied wholly or partly in securities for which listing is being sought, the listed issuer must immediately announce the transaction in accordance with paragraph 10.06.

10.06 Requirements for transactions with percentage ratio of 5% or more

- (1) Where any one of the percentage ratios of a transaction is 5%, or more, the listed issuer must announce the transaction to the Exchange as soon as possible after terms of the transaction have been agreed. The listed issuer must include the information set out in Appendix 10A in the announcement.
- (2) The listed issuer must also furnish the Exchange, in a separate letter, the percentage ratios applicable to such transaction.
- (3) Subparagraphs (1) and (2) do not apply to a transaction where the value of the consideration of the transaction is less than RM250,000.

10.07 Requirements for transactions with percentage ratio of 25% or more

- (1) Where any one of the percentage ratios of a transaction is 25% or more, in addition to the requirements of paragraph 10.06, the listed issuer must -
 - (a) issue a circular which includes the information set out in Appendix 10B to its shareholders; and
 - (b) seek shareholder approval of the transaction in a general meeting.
- (2) The listed issuer ~~or its Principal Adviser~~ must submit the draft circular to the Exchange together with a checklist showing compliance with Appendix 10B.
- (3) Subparagraphs (1) and (2) do not apply to a transaction where the value of the consideration of the transaction is less than RM250,000.

PART E - RELATED PARTY TRANSACTIONS**10.08 Related party transactions**

(1) Where any one of the percentage ratios of a related party transaction is 0.25% or more, a listed issuer must announce the related party transaction to the Exchange as soon as possible after terms of the transaction have been agreed, unless -

- (a) the value of the consideration of the transaction is less than RM250,000; or
- (b) it is a Recurrent Related Party Transaction.

The listed issuer must include the information set out in Appendices 10A and 10C in the announcement.

(2) Subject to subparagraphs (9) and (10) below, where any one of the percentage ratios of a related party transaction is 5% or more, in addition to subparagraph (1), a listed issuer must -

- (a) send a circular which includes the information set out in Appendix 10B and Appendix 10D to the shareholders. The draft circular must be submitted to the Exchange together with a checklist showing compliance with Appendices 10B and Appendix 10D;
- (b) obtain its shareholder approval of the transaction in general meeting; and
- (c) appoint an independent adviser who is a corporate finance adviser within the meaning of the SC's Principal Adviser Guidelines, before the terms of the transaction are agreed upon.

(3) The independent adviser must, in relation to the transaction -

- (a) comment as to -
 - (i) whether the transaction is fair and reasonable so far as the shareholders are concerned; and
 - (ii) whether the transaction is to the detriment of minority shareholders,and such opinion must set out the reasons for, the key assumptions made and the factors taken into consideration in forming that opinion;
- (b) advise minority shareholders on whether they should vote in favour of the transaction; and
- (c) take all reasonable steps to satisfy itself that it has a reasonable basis to make the comments and advice in subparagraphs (a) and (b) above.

(4) Subject to subparagraph (9) below, for a related party transaction where any one of the percentage ratios is 25% or more, in addition to subparagraph (2) above, the listed issuer must, before the terms of the transaction are agreed upon, appoint a main adviser, who is a Principal Adviser. The Principal Adviser must -

- (a) ensure that such transaction -
 - (i) is carried out on fair and reasonable terms and conditions, and not to the detriment of minority shareholders of the listed issuer; and

-
- (ii) complies with the relevant laws, regulations or guidelines, where applicable;
 - (b) ensure full disclosure of all information required to be disclosed in the announcement and circular; and
 - (c) confirm to the Exchange after the transaction has been completed and all the necessary approvals have been obtained, that it has discharged its responsibility with due care in regard to the transaction.
 - (5) The Exchange has the discretion not to allow an independent adviser to continue to act or be appointed as an independent adviser if, in its opinion, the adviser is deemed not to be independent.
 - (6) A director with any interest, direct or indirect, ("**interested director**") must abstain from board deliberation and voting on the relevant resolution in respect of the related party transaction.
 - (7) In a meeting to obtain shareholder approval -
 - (a) the interested director, major shareholder or person connected with a director or major shareholder with any interest, direct or indirect ("**interested major shareholder**" or "**interested person connected with a director or major shareholder**"); and
 - (b) where it involves the interest of an interested person connected with a director or major shareholder, such director or major shareholder,must not vote on the resolution approving the transaction. An interested director or interested major shareholder must ensure that persons connected with him abstain from voting on the resolution approving the transaction.
 - (8) An interested director in a related party transaction, must inform the board of directors of the listed issuer or its subsidiary, as the case may be, the details of the nature and extent of his interest, including all matters in relation to the proposed transaction that he is aware or should reasonably be aware of, which is not in the best interest of the listed issuer or its subsidiary, as the case may be.
 - (9) Where any one of the percentage ratios of a related party transaction entered into between a subsidiary of a listed issuer and another person, is 5% or more and there are no other interested relationships except for a related party having an interest in the transaction who is -
 - (a) a director or major shareholder of such subsidiary or the holding company of such subsidiary (other than the listed issuer or a holding company of the listed issuer) ("**said director**" or "**said major shareholder**"); or
 - (b) a person connected with the said director or said major shareholder;the listed issuer is exempted from -
 - (i) issuing a circular to shareholders;
 - (ii) obtaining shareholder approval of the transaction in general meeting; and
 - (iii) appointing a main adviser and independent adviser, as the case may be;provided that the board of directors of the listed issuer -
 - (aa) approves the transaction before the terms of transaction are agreed upon; and

- (bb) ensures that the transaction is fair and reasonable to the listed issuer and is in the best interests of the listed issuer.
- (10) Subparagraphs (1), (2), (3), (4) and (9) do not apply to a related party transaction where the value of the consideration of the transaction is less than RM250,000.
- (11) The following transactions are not normally regarded as related party transactions:
- (a) the payment of dividend, issue of securities by the listed issuer by way of a bonus issue or for cash (subject to paragraph 6.06), subdivision of shares, consolidation of shares or reduction in the par value of shares;
 - (b) a transaction between a listed issuer or any of its subsidiaries and an investee ~~company corporation~~, where the related party has no interest in the investee ~~company corporation~~ other than via the listed issuer;
 - (c) a transaction between the listed issuer or any of its subsidiaries and another person, where there are no other interested relationships except for common directorships provided that the directors who have common directorships have -
 - (i) shareholdings in the other person which is less than 1% other than via the listed issuer; and
 - (ii) no other interest such as commission or other kinds of benefit received from the listed issuer or any of its subsidiaries or the other person in relation to the said transaction;
 - (d) an acquisition or disposal by the listed issuer or any of its subsidiaries from or to a third party of an interest in another ~~company corporation~~ where the related party holds less than 5% in that other ~~company corporation~~ other than via the listed issuer;
 - (e) the provision or receipt of financial assistance or services, upon normal commercial terms and in the ordinary course of business, from a ~~company corporation~~ whose activities are regulated by any written law relating to banking, finance ~~companies corporations~~ or insurance and are subject to supervision by Bank Negara Malaysia;
 - (f) directors fees and remuneration, and employment remuneration;
 - (g) a transaction between a listed issuer or any of its subsidiaries and another person for the provision or receipt of goods or services which are Exempted Transactions where -
 - (i) the goods or services are purchased, sold or rendered based on a non-negotiable fixed price or rate which is published or publicly quoted; and
 - (ii) all material terms including the prices or charges are applied consistently to all customers or classes of customers;
- For the purposes of this subparagraph -
- (i) "**goods**" excludes securities;
 - (ii) "**classes of customers**" excludes such class by reason solely or otherwise that the customers are related parties of the listed issuer or its subsidiaries;

-
- (iii) **"Exempted Transactions"** means the following:
- (aa) provision or usage of public utility services such as water, electricity, telecommunications, postal or courier services, insurance, unit trusts, stockbroking services, public transport, education, medical services, provision or usage of tolled highways, hotel facilities and recreational services, provision or consumption of fuel on retail or food and beverage at eateries, provision or purchase of goods at retail outlets such as supermarkets, hypermarkets or departmental stores; and
 - (bb) such other types of transactions that may be prescribed by the Exchange from time to time;
- (h) the entry into or renewal of tenancy of properties of not more than 3 years, the terms of which are supported by an independent valuation;
- (i) a contract that is awarded by or on behalf of the Government of Malaysia or a State Government to the listed issuer or its subsidiary provided that the listed issuer immediately announces the contract to the Exchange and includes the information set out in Appendices 10A and 10C in the announcement;
- (j) a contract that is awarded by way of a public tender -
- (i) in relation to the listed awarder or its subsidiaries provided that -the listed issuer immediately announces to the Exchange the terms of the awarded contract and the value of at least the 3 closest bids or if not applicable, such lesser number of bids received; and
 - (ii) in relation to the successful listed bidder or its subsidiaries provided that -
 - (aa) the awarder is listed or is a subsidiary of a listed issuer;
 - (bb) majority of the directors and members of the audit committees of the listed issuers (whether as the bidder or the awarder or the holding companies of the bidder or awarder subsidiaries) are different; and
 - (cc) the listed bidder immediately announces the contract to the Exchange and includes the information set out in Appendices 10A and 10C in the announcement;
- (k) a transaction between a listed issuer or any of its subsidiaries and another person which involves the sharing of services or facilities provided by one or more of such parties or other similar arrangements whereby the consideration merely involves reimbursement or sharing of costs in proportion to the utilisation of the services or facilities;
- (l) a transaction between the listed issuer or any of its subsidiaries and another person where there are no other interested relationships except for the related party having shareholdings in the other person which is less than 5% other than via the listed issuer.
- (m) a transaction between the listed issuer or any of its subsidiaries and another person where there are no other interested relationships except for -
- (i) common major shareholders; or

- (ii) a person connected with a major shareholder being a major shareholder of the other person,

provided that the following conditions are satisfied:

- (aa) the major shareholder and/or the person connected with the major shareholder is/are not the largest shareholder of the listed issuer;
- (bb) the major shareholder and/or the person connected with the major shareholder is/are not a party to the said transaction, initiator, agent or involved in any other manner in the said transaction;
- (cc) the major shareholder does not have any representative in an executive capacity on the board of directors of the listed issuer or any of its subsidiaries; and
- (dd) the major shareholder is -
- (A) a statutory institution who is managing funds belonging to the general public;
 - (B) a closed end fund, unit trust or investment fund (but excluding an investment holding company); or
 - (C) an insurance ~~company~~ corporation whose activities are regulated by any written law relating to insurance and are subject to supervision by Bank Negara Malaysia and the said insurance ~~company~~ corporation is managing its insurance funds (together with its own shareholders' funds or otherwise). For the purposes of this subparagraph, "insurance funds" has the meaning given in section 2 of the Insurance Act, 1996;
- (n) a transaction between the listed issuer and another person where there are no other interested relationships except for a related party who is a director or major shareholder of a subsidiary of the listed issuer or person connected with such director or major shareholder having an interest in the transaction;
- (o) a transaction between a subsidiary of a listed issuer ("**transacting subsidiary**") and another person where there are no other interested relationships except for a related party who is a director or major shareholder of a subsidiary of the listed issuer (other than the transacting subsidiary or holding companies of the transacting subsidiary) or a person connected with such director or major ~~shareholder~~ shareholder having an interest in the transaction;
- (p) subscription to or acquisition by a listed issuer or its unlisted subsidiaries of debt securities and/or redeemable preference shares issued by or on behalf of the Government of Malaysia, Bank Negara Malaysia and/or a State Government; or
- (q) a disposal by a listed issuer or any of its subsidiaries of an interest in an investee ~~company~~ corporation where a related party is also a major shareholder or person connected with a major shareholder of the investee ~~company~~ corporation (other than via the listed issuer), provided that -
- (i) the related party, person connected with the related party or both, are not a party, initiator or agent to the said disposal; and

- (ii) the disposal is effected on the Exchange where the counterparty's identity is unknown to the listed issuer or its subsidiaries (as the case may be) at the time of the disposal.

For the purpose of this subparagraph (q), a “**disposal**” includes a disposal by a listed issuer or any of its subsidiaries of an interest in an investee company corporation on a pro-rata basis or arising from an acceptance of a take-over offer, except that subparagraph (q)(ii) above will not be applicable in such instances.

10.09 Recurrent Related Party Transactions

- (1) Notwithstanding paragraph 10.08(1)(b) above, a listed issuer must immediately announce a Recurrent Related Party Transaction as follows:
 - (a) in relation to a listed issuer with an issued and paid-up capital of RM60 million and above -
 - (i) the consideration, value of the assets, capital outlay or costs of the Recurrent Related Party Transactions is RM1 million or more; or
 - (ii) the percentage ratio of such Recurrent Related Party Transaction is 1% or more,whichever is the higher; or
 - (b) in relation to a listed issuer with an issued and paid-up capital which is less than RM60 million -
 - (i) the consideration, value of the assets, capital outlay or costs of the Recurrent Related Party Transaction is RM1 million or more; or
 - (ii) the percentage ratio of such Recurrent Related Party Transaction is 1% or more,whichever is the lower.
- (2) A listed issuer may seek a mandate from its shareholders for Recurrent Related Party Transactions subject to the following:
 - (a) the transactions are in the ordinary course of business and are on terms not more favourable to the related party than those generally available to the public;
 - (b) the shareholder mandate is subject to annual renewal and disclosure is made in the annual report of the aggregate value of transactions conducted pursuant to the shareholder mandate during the financial year where the aggregate value is equal to or more than the threshold prescribed under subparagraph (1) above;
 - (c) the listed issuer's circular to shareholders for the shareholder mandate includes the information as may be prescribed by the Exchange. The draft circular must be submitted to the Exchange together with a checklist showing compliance with such information;
 - (d) in a meeting to obtain shareholder mandate, the interested director, interested major shareholder or interested person connected with a director or major shareholder; and where it involves the interest of an interested person connected with a director or major shareholder, such director or major shareholder, must not vote on the resolution to approve the transactions. An interested director or interested major

shareholder must ensure that persons connected with him abstain from voting on the resolution approving the transactions; and

- (e) the listed issuer immediately announces to the Exchange when the actual value of a Recurrent Related Party Transaction entered into by the listed issuer, exceeds the estimated value of the Recurrent Related Party Transaction disclosed in the circular by 10% or more and must include the information as may be prescribed by the Exchange in its announcement.

[Cross reference: Practice Note 12]

- (3) Where a listed issuer has procured a shareholder mandate pursuant to subparagraph (2) above, the provisions of paragraph 10.08 -will not apply.

PART F - VERY SUBSTANTIAL TRANSACTION AND SIGNIFICANT CHANGE IN THE BUSINESS DIRECTION OR POLICY

10.10 Very substantial transaction

Where a transaction is a very substantial transaction, a listed issuer ~~and its Principal Adviser~~ must include additional information set out in Part G of Appendices 10A and 10B, respectively, in the announcement of the transaction to the Exchange and the circular issued to the shareholders.

10.11 Significant change in the business direction or policy of a listed issuer

- (1) Where a transaction will result in a significant change in the business direction or policy of the listed corporation, the listed issuer must first procure the SC's approval for the transaction.
- (2) The listed issuer must include additional information set out in Part H of Appendices 10A and 10B respectively, in the announcement of the transaction to the Exchange and the circular issued to the shareholders, as the case may be.
- (3) The listed issuer must submit the circular referred to in subparagraph (2) above to the SC for comments and clearance before it issues the circular to its shareholders. For the avoidance of doubt, any application in relation to the waiver or modification of the contents required of such a circular must be submitted directly to the SC for approval.

PART G - OTHER REQUIREMENTS

10.12 Aggregation of transactions

- (1) The Exchange may aggregate separate transactions and treat such transactions as if they were one transaction if the terms of such transactions were agreed upon within a period of 12 months.
- (2) Without prejudice to the generality of subparagraph (1) above, transactions which may be aggregated in accordance with that subparagraph include the following:
 - (a) transactions entered into with the same party or with parties connected with one another;
 - (b) transactions involving the acquisition or disposal of securities or interests in one particular corporation /asset; or

- (c) transactions involving the acquisition or disposal of various parcels of land contiguous to each other.

[Cross reference: Practice Note 14]

10.13 Diversification in operations carried on by a listed issuer

- (1) A listed issuer must obtain its shareholder approval in a general meeting for any transaction or business arrangement which might reasonably be expected to result in either -
- (a) the diversion of 25% or more of the net assets of the listed issuer to an operation which differs widely from those operations previously carried on by the listed issuer; or
- (b) the contribution from such an operation of 25% or more of the net profits of the listed issuer.

In assessing the extent of diversification or the amount of contribution to the net profits, consideration should be taken of any associated transactions or loans effected or intended and of contingent liabilities or commitments.

- (2) For the purpose of subparagraph (1) above, the Exchange may aggregate separate transactions and treat such transactions as if they were one transaction if the terms of such transactions were agreed upon within a period of 12 months and the total percentage ratio of assets allocated for the diversification is 25% or more.

PART H – QUALIFYING ACQUISITION OF A SPECIAL PURPOSE ACQUISITION COMPANY

10.14 ~~Approvals to complete~~Completion of a qualifying acquisition

- (1) A SPAC must ~~not proceed to complete a qualifying acquisition unless comply with the following in relation to the completion of a qualifying acquisition:-~~
- ~~(a) the SPAC convenes a general meeting to obtain the approval of its holders of the voting securities;~~
- (a) the SPAC obtains the SC's approval for the qualifying acquisition;
- (b) where the qualifying acquisition comprises more than one acquisition, the sale and purchase agreements relating to each of the acquisitions are inter-conditional and must complete simultaneously within 36 months from the date of listing of the SPAC on the Exchange; and
- (c) the respective resolution on each qualifying acquisition is approved by a majority in number of the holders of voting securities representing at least 75% of the total value of securities held by all holders of voting securities present and voting either in person or by proxy at a general meeting duly convened for that purpose; ~~and~~
- ~~(d) the SPAC has obtained the SC's approval for the qualifying acquisition.~~
- (2) A member of the management team and persons connected with them must not vote on a resolution approving a qualifying acquisition.

- (3) The listed issuer must include additional information set out in –
- (a) Part H of Appendix 10A, in the announcement of the transaction to the Exchange; and
 - (b) Parts H and I of Appendix 10B, in the circular issued to the shareholders.
- (4) The listed issuer must submit the circular referred to in subparagraph (3) above to the SC for comments and clearance before it issues the circular to its shareholders. For the avoidance of doubt, any application in relation to the waiver or modification of the contents required of such a circular must be submitted directly to the SC for approval.

[End of Chapter]

APPENDIX 10A**Contents of announcement in relation to transactions**

(paragraphs 10.06(1), 10.08(1), 10.08(11)(i) and (j))

Part A**General information to be included, where applicable, in announcement of transactions**

- (1) The details of the transaction including particulars of the assets being acquired or disposed of.;
- (2) A description of the business carried on.;
- (3) The total consideration, together with –
 - (a) the basis of arriving at the consideration. If it was based on net assets, the year the net assets ~~was~~ were taken into consideration, quantifying the net assets and stating whether it was based on audited financial statements;
 - (b) the justification for the consideration; and
 - (c) the manner in which the consideration will be satisfied including the terms of any arrangement for payment on a deferred basis.;
- (4) The financial information on the assets which are the subject matter of the transaction, including but not limited to, net profits attributable to assets and net assets or net book value of the assets.;
- (5) The effect of the transaction on the listed issuer, which includes the effect of the transaction on the earnings per share, net assets per share, gearing, share capital and substantial shareholders' shareholding of the listed issuer.;
- (6) In the case of a disposal -
 - (a) the expected gains or losses to the group;
 - (b) where the sale consideration is to be satisfied in cash the intended application of the sale proceeds and the breakdown, including the timeframe for full utilisation of proceeds, and details of the purchaser;
 - (c) where shares or other securities are intended to form part of the consideration -
 - (i) the number, type and par value of securities to be issued;
 - (ii) the ranking of the securities;
 - (iii) the issue price, basis of determining the issue price and justification for the pricing of the securities;
 - (iv) a statement as to whether such securities are to be sold or retained;
 - (v) the principal activities and issued and paid-up capital of the ~~company~~ corporation in which the securities are or will be held; and
 - (vi) the names of the directors and substantial shareholders of the ~~company~~ corporation in which the securities are or will be held;

Appendix 10A
Contents of announcement for transactions

-
- (d) particulars of all liabilities to be assumed by the purchaser arising from the transaction;
 - (e) the original cost of investment and the date of such investment; and
 - (f) -if the disposal is expected to result in the listed issuer becoming a Cash Company or a PN17 Company, a statement to that effect.⋮
- (7) In the case of an acquisition -
- (a) where the consideration is to be satisfied in whole or in part by an issue of securities of the listed issuer -
 - (i) the number, type and par value of securities to be issued;
 - (ii) the ranking of the securities;
 - (iii) whether listing will be sought for the securities;
 - (iv) -the issue price, basis of determining the issue price and justification for the pricing of the securities;
 - (v) if the vendor is a **company corporation**, the name and principal activity of the vendor and names of its directors and substantial shareholders together with their respective shareholdings; and
 - (vi) if the vendor is an individual, the name of the vendor;
 - (b) where the purchase consideration is to be satisfied by cash, the source of funding, its breakdown and details of the vendor; and
 - (c) particulars of all liabilities, including contingent liabilities and guarantees to be assumed by the listed issuer, arising from the transaction.
- (8) Where the consideration is in the form of equity share capital, the weighted average market price for the equity share capital for the 5 market days before the date on which the terms of the transaction were agreed upon.⋮
- (9) Whether the transaction is subject to the shareholder approval -and the relevant government authorities and the estimated time frame for submission of the application to the relevant authorities.⋮
- (10) Whether the directors and/or major shareholders and/or persons connected with a director or major shareholder have any interest, direct or indirect, in the transaction and the nature and extent of their interests.⋮
- (11) The rationale for the transaction including any benefit which is expected to accrue to the listed issuer as a result of the transaction.⋮
- (12) The salient features of the agreement and valuation report, if any, and the time and place where such documents may be inspected.⋮
- (13) The date on which the terms of the transaction were agreed upon.⋮

Appendix 10A
Contents of announcement for transactions

-
- (14) A statement by the board of directors, excluding interested directors stating whether the transaction is in the best interests of the listed issuer, and where a director disagrees with such statement, a statement by the director setting out the reasons and the factors taken into consideration in forming that opinion.;
- (15) The prospects of the assets or interests to be acquired.;
- (16) The risks in relation to the transaction including risk factors of the assets or interests to be acquired.;
- (17) The estimated time frame ~~for the completion of~~ to complete the transaction.;
- (18) The highest percentage ratio applicable to the transaction pursuant to paragraph 10.02(g) of these Requirements.;
- (19) Where any one of the percentage ratios is 25% or more, the following information must be included:
- (a) where a feasibility report in relation to the transaction has been prepared, the name of the expert who prepared the report and a brief conclusion of the report. To state the time and place where such report may be inspected;
 - (b) the estimated additional financial commitment required of the corporation in putting the assets acquired on-stream;
 - (c) for depleting or specialised businesses, such as timber concessions and oil and gas businesses, information on the reserves, extraction rates and returns;
 - (d) where another corporation is acquired or disposed of, or where shares or other securities in another corporation are to be received as consideration for a disposal, the following information in respect of the other corporation in an appendix:
 - (i) the general nature of business conducted by the corporation and its subsidiaries including principal products manufactured or services rendered and principal markets for the products or services;
 - (ii) the audited financial information (past 3 years or since incorporation, whichever is the later) and the latest interim results, if available, stating turnover, profit before tax and profit after tax and minority interest; and
 - (iii) where there is any material fluctuation in turnover or profits in any of the years, the explanation for the fluctuation.;
- (20) Any other information which is necessary to enable an investor to make an informed investment decision.

Part B**Additional specific information to be included in relation to joint-ventures**

- (1) The details of the joint-venture partners.;
- (2) The breakdown of the total capital and investment outlay in the joint-venture.;
- (3) The eventual issued and paid-up capital of the joint-venture ~~corporation~~ company.;

Appendix 10A
Contents of announcement for transactions

-
- (4) The number, type and par value of the shares. Where there is more than one type of shares or securities issued, the following:
 - (a) the differences between the different types of shares or securities;
 - (b) whether convertible; if so, the rate and period ;
 - (c) whether redeemable; if so, the rate and period ; and
 - (d) the tenure.;
 - (5) The equity interest held and to be held by the respective parties.;
 - (6) The name of the joint-venture corporationcompany.;
 - (7) The source(s) of funds for financing the investment in the joint-venture corporationcompany, and the breakdown.;
 - (8) If no joint-venture corporationcompany will be set up, the terms of cost and profit sharing and the estimated total cost of project.

Part C**Additional specific information to be included in relation to a transaction which involves an acquisition or disposal of real estate**

- (1) A description of each real estate including -
 - (a) the postal address or identification (lot, title number, relevant mukim, district and state) of the real estate;
 - (b) a brief description (e.g. whether land or building, approximate area, etc.);
 - (c) the existing and proposed use (e.g. shops, offices, factories, residential, etc.). If currently let out or is proposed to be let out, the details of the rentals and the rental income or expected rental income per month or per annum. If the real estate to be disposed is currently used as a factory, the effect of a disposal on the operations;
 - (d) the approximate age of the buildings;
 - (e) the terms of the tenure; if leasehold, the expiry date of the lease;
 - (f) whether any valuation was carried out on the real estate; if so, the name of the independent registered valuer, date and method of valuation and quantification of the market value;
 - (g) the net book value based on latest audited financial statements; and
 - (h) the encumbrances, if any.;
- (2) If the real estate acquired or disposed of is an estate or plantation, the following additional information:
 - (a) the present and future usage;

-
- (b) the type of estate or plantation;
 - (c) the maturity of the trees; and
 - (d) the production for the past 3 years.;
- (3) Where the real estate consist of buildings, the following:
- (a) the amount of lettable space;
 - (b) the amount of lettable space available for letting and the occupancy; and
 - (c) the percentage of occupancy.;
- (4) Where the real estate is in the process of being developed or is intended to be developed, the following additional details:
- (a) the details of development potential, i.e. name of the project, type of development - residential, industrial or commercial, number of units in respect of each type of development;
 - (b) the total development cost;
 - (c) the expected commencement and completion date(s) of development;
 - (d) the expected profits to be derived;
 - (e) the stage or percentage of completion;
 - (f) the sources of funds to finance the development cost; and
 - (g) whether relevant approvals for the development have been obtained and date(s) obtained.

Part D**Additional specific information to be included in relation to acquisitions or disposals of construction ~~companies~~corporations**

- (1) A description of the current projects undertaken by the ~~corporation~~company – type of construction, name of the project, owner of the project, and value.;
- (2) The expected commencement and completion date(s) of construction.;
- (3) The contract value of the recent major projects completed and current projects on hand.

Part E**Additional specific information to be included in relation to acquisitions or disposals of infrastructure project asset/ business or corporations involved in infrastructure projects**

- (1) The pertinent details of the concession/license, including but not limited to -
 - (a) nature of the concession/license (e.g. Build-Operate-Transfer, Build-Transfer-Operate, Build-Own-Operate, etc.);

Appendix 10A
Contents of announcement for transactions

-
- (b) life/duration and exclusivity/non-exclusivity of the concession/license;
 - (c) salient terms and conditions of the concession/license;
 - (d) infrastructure project ~~company corporation~~'s rights, interest and major obligations under the concession/license; and
 - (e) Acts/regulations under which the concession/license is granted;
- (2) The nature of relationship with the concession giver/licensor; ~~and~~
 - (3) The details of financing requirements and sources of funding.

Part F**Additional specific information to be included in relation to foreign acquisitions where any one of the percentage ratios is 25% or more**

- (1) The financial and other relevant information pertaining to the ~~companies corporation~~ and/or assets to be acquired including a summary of the key audited financial data of the assets or interests to be acquired for the past 3 financial years or since the date of incorporation or commencement of operations, whichever is the later. The financial data must include, but not be limited to, turnover, pre-tax profit, after-tax profit, shareholders' funds and total borrowings; ~~and~~
- (2) The policies on the foreign investments and repatriation of profits of the host country.

Part G**Additional specific information to be included in relation to very substantial transactions**
(paragraph 10.10)

- (1) A summary of the key audited financial data of the assets of business or interests to be acquired for the past 3 financial years or since the date of incorporation or commencement of operations, whichever is the later. The financial data must include, but not be limited to, shareholders' funds and total borrowings; ~~and~~
- (2) ~~An accountant's report on the unlisted company to be acquired;~~ The financial effects on proforma net assets (based on the latest audited financial statements) of the listed issuer on completion of the acquisition or restructuring exercise.
- (3) For assets or interests to be acquired which do not have any profitability track record (as in certain privatisation cases), the information must include, but not be limited to, the total cost needed to put on-stream the operation of the assets or interests and the proportion to be assumed or guaranteed by the listed issuer, the expected date on which the profit contribution will accrue to the listed issuer and the expected returns to be derived, together with the appropriate assumptions used. Information provided should be verified and confirmed by independent experts.

Part H**Additional specific information to be included in relation to significant change in business direction or policy of a listed corporation**

(paragraphs 10.11 & 10.14)

- (1) A summary of the key audited financial data of the assets or interests to be acquired for the past 3 to 5 financial years (depending on the profit track record used for compliance with the SC's Equity Guidelines) or since the date of incorporation or commencement of operations, whichever is the later. The financial data must include, but not be limited to, shareholders' funds and total borrowings.†
- (2) The financial effects on proforma net assets (based on the latest audited financial statements) of the listed issuer on completion of the acquisition or restructuring exercise.†
- (3) For assets or interests which do not have any profitability track record (as in certain privatisation cases), the information must include, but not be limited to, the total cost needed to put on-stream the operation of the assets or interests and the proportion to be assumed or guaranteed by the listed issuer, the expected date on which profit contribution will accrue to the listed issuer and the expected returns to be derived.†
- (4) If the transaction results in a change in the controlling shareholder of the listed issuer, a statement to that effect and the following information in respect of the new shareholder:
 - (a) the name;
 - (b) the date and place of incorporation;
 - (c) the names of directors and substantial shareholders and their respective shareholdings; and
 - (d) the principal business.†
- (5) If the transaction results in a change in the board of directors of the listed corporation, the following information in respect of the new board of directors:
 - (a) name and nationality; and
 - (b) occupation and qualification.†
- (6) Background of the vendors who are substantial shareholders of the assets or interests to be acquired:
 - (a) name;
 - (b) date and place of incorporation;
 - (c) principal activities;
 - (d) substantial shareholders and directors and their respective shareholdings.

[End of Appendix]

APPENDIX 10B**Contents of circular to shareholders in relation to transactions**

(paragraphs 10.07(1) and 10.08(2)(a))

Part A**General information to be included, where applicable, in the circular to shareholders in relation to transactions**

- (1) If voting or other action is required, a heading drawing attention to the importance of the document and advising holders of securities who are in any doubt as to what action to take to consult appropriate independent advisers.
- (2) A statement that Bursa Malaysia Securities Berhad takes no responsibility for the contents of the circular, makes no representation as to its accuracy or completeness and expressly disclaims any liability whatsoever for any loss howsoever arising from or in reliance upon the whole or any part of the contents of the circular. In relation to an Exempt Circular, a statement that Bursa Malaysia Securities Berhad has not perused the circular before its issuance.
- (3) The purpose of the circular.
- (4) The date on which terms of the transaction were agreed upon and the date on which the transaction and any revision to it was announced.
- (5) The particulars of the transaction, including a description of the company-corporation or assets to be acquired or disposed of, as the case may be.
- (6) The salient features of the agreement relating to the transaction.
- (7) The details of any other intended corporate exercise/scheme which have been announced but not yet completed before the printing of the circular and whether the transaction is conditional or inter-conditional upon such and/or any other corporate exercise/scheme.
- (8) The audited financial and other relevant information pertaining to the assets, including but not limited to the net book value of the assets.
- (9) The total consideration, together with -
 - (a) the basis of arriving at the consideration. If it was based on net assets, the year the net asset was taken into consideration, quantifying the net assets and stating whether it was based on audited financial statements; and
 - (b) the justification for the consideration.
- (10) How the consideration will be satisfied including the terms of any arrangement for payment on a deferred basis.
- (11) In the event the consideration is based on or involves a profit guarantee, details of the listed issuer's right of recourse in the event the profit guarantee is not met.
- (12) The effects of each transaction on -
 - (a) the share capital, and substantial shareholders' shareholdings based on the latest practicable date;

Appendix 10B
Contents of circular for transactions

-
- (b) the net assets per share and gearing based on the latest audited consolidated financial statements for the most recently completed financial period, assuming that the transaction had been effected at the end of that financial period; and
- (c) the earning per share based on the latest audited consolidated financial statements for the most recently completed financial period, assuming that the transaction had been effected at the beginning of that financial period.
- (13) In the case of an acquisition -
- (a) where the consideration is to be satisfied in whole or in part by an issue of securities of the listed issuer -
- (i) the number, type and par value of securities to be issued;
- (ii) the ranking of the securities;
- (iii) the issue price, basis of determining the issue price and the justification for the pricing of the securities;
- (iv) if the vendor is a company corporation, the name and principal activity of the vendor and names of its directors and substantial shareholders together with their respective shareholdings;
- (v) if the vendor is an individual, the name of the vendor; and
- (vi) the highest and lowest prices of such securities as transacted on the Exchange for the preceding 12 months including the last transacted price before the announcement on the transaction and on the latest practicable date before the printing of the circular;
- (b) where the purchase consideration is to be satisfied wholly or partly by cash, the source(s) of funding, the breakdown -and details of the vendor;
- (c) a statement as to whether the company corporation and/or assets will be acquired free from encumbrances; and
- (d) the particulars of all liabilities, including contingent liabilities and guarantees to be assumed by the listed issuer arising from the acquisition.
- (14) In the case of a disposal -
- (a) the expected gains or losses to the group;
- (b) the subject matter's contribution to the group's net profit based on the latest audited financial statements;
- (c) where the sale consideration is to be satisfied in cash, the intended application of the sale proceeds and the breakdown, including the timeframe for the full utilisation of proceeds, and if the proceeds are to be used for -
- (i) reducing borrowings, the quantification of the total borrowings of the group as at the latest practicable date before printing of the circular and the savings in interest payment or expense per annum arising from the repayment; and

Appendix 10B
Contents of circular for transactions

-
- (ii) -details of the investments. If these have not yet been identified, a statement of how the proceeds will be utilised in the meantime, pending identification of the investments;
 - (d) where shares or other securities are intended to form part of the consideration -
 - (i) the number, type and par value of securities to be issued;
 - (ii) the ranking of the securities;
 - (iii) whether listing will be sought for the securities;
 - (iv) the issue price, the basis of determining the issue price and the justification for the pricing of the securities; and
 - (v) a statement as to whether such securities are to be sold or retained;
 - (e) the original cost of investment and the date of such investment;
 - (f) details of the purchaser;
 - (g) particulars of all liabilities to be assumed by the purchaser arising from the transaction; and
 - (h) if the disposal is expected to result in the listed issuer becoming a Cash Company or a PN17 Company, a statement to that effect;
- (15) The rationale for the transaction including any benefit which is expected to accrue to the listed issuer as a result of the transaction;
- (16) Where a feasibility report in relation to the acquiree ~~corporation~~ company and assets has been prepared, the name of the expert who prepared the report and a brief conclusion of the report. Incorporate the letter from the expert, and make available for inspection the report and letter;
- (17) In relation to the assets or interests to be acquired -
- (a) a description of the assets or interest to be acquired and outlook of the industry where it operates;
 - (b) the prospects of the assets or interests in light of its industry's outlook and competition; and
 - (c) a description of the future plans of the assets or interests and steps to be taken (including time frame and financial resources required to be committed) to realise such plans;
- (18) The risks in relation to -
- (a) the transaction;
 - (b) the assets or interests to be acquired (as well as the ~~company~~ corporation whose securities are to be received as consideration for the disposal); and
 - (c) the overall industry where the assets or interests to be acquired operates,

Appendix 10B
Contents of circular for transactions

-
- which had or could materially affect, directly or indirectly, the business, operating results and financial condition of the listed issuer and the mitigating factors.;
- (19) The estimated additional financial commitment required of the ~~company~~ corporation in putting the assets acquired on-stream.;
- (20) The tentative timetable for the implementation of the proposal.;
- (21) The valuation of the assets as at the latest practicable date, if applicable, and the name of the independent registered valuers.;
- (22) For depleting or specialised businesses, such as timber concessions and oil and gas businesses, information on the breakdown of assets/inventories, reserves, extraction rates and returns.;
- (23) Whether the transaction is subject to the approval of shareholders and the relevant government authorities, the conditions imposed and the status of compliance.;
- (24) Whether the directors and/or major shareholders and/or persons connected with a director or major shareholder have any interest, direct or indirect, in the transaction and the nature and extent of their interests.;
- (25) A statement by the board of directors, excluding interested directors, stating whether the transaction is in the best interests of the listed issuer, and where a director disagrees with such statement, a statement by the director setting out the reasons and the factors taken into consideration in forming that opinion.;
- (26) In the case of an acquisition, where the purchase consideration is based on or involves a profit guarantee, a statement as to whether the profit guarantee provided is realistic, taking into consideration the historical performance and future prospects of the ~~company~~ corporation and/or asset to be acquired.;
- (27) A recommendation ~~for~~ from the directors and the basis of such recommendation from the directors, excluding interested directors, as to the voting action shareholders should take.;
- (28) Where another ~~company~~ corporation is acquired or disposed of, or where shares or other securities in another ~~company~~ corporation are to be received as consideration for a disposal, the following information in respect of the other ~~company~~ corporation in an appendix:
- (a) the date and place of incorporation;
 - (b) the authorised and issued and paid-up capital;
 - (c) the number, type and par value of the shares making up the share capital. Where there is more than one type of shares or securities in issue, the following:
 - (i) the differences between the different types of securities;
 - (ii) whether convertible; if so, the rate and period;
 - (iii) whether redeemable; if so, the rate and period; and
 - (iv) the tenure;

Appendix 10B
Contents of circular for transactions

-
- (d) the following details of its subsidiaries and associated companies:
- (i) the name;
 - (ii) the date and place of incorporation;
 - (iii) the issued and paid-up capital;
 - (iv) the percentage of effective interest of the ~~company~~ corporation; and
 - (v) the principal activities;
- (e) a brief history of the ~~company~~ corporation or business for the past 3 year or since inception, whichever is the later, and if reorganised as a result of merger, consolidation or reorganisation, similarly the history of the predecessor ~~companies~~ corporations;
- (f) the general nature of business conducted by the ~~company~~ corporation and its subsidiaries including principal products manufactured or services performed; size and location of the factories; principal markets for the products and raw materials; percentage of sales broken down between domestic and foreign; annual production capacity and output for the past 3 years and if significant, the amount spent on and number of persons employed in research and development;
- (g) the details of material commitments and contingent liabilities incurred or known to be incurred by the acquiree ~~company~~ corporation and impact on profits or net assets upon becoming enforceable;
- (h) the type of businesses or assets owned;
- (i) the particulars of directors including name, nationality, designation and their direct and indirect shareholdings;
- (j) the particulars of substantial shareholders including name, nationality, country of incorporation and their direct and indirect shareholdings;
- (k) the financial information based on the audited financial statements (past 3 years or since incorporation, whichever is the later) and the latest interim results, if available, stating -
- (i) the turnover;
 - (ii) the profit before tax but after minority interest;
 - (iii) the profit after tax and minority interest;
 - ~~(iv)~~ the gross earnings per share (EPS);
 - (v) the net EPS;
 - (vi) the paid-up capital;
 - (vii) the shareholders' funds;
 - (viii) the net assets;

Appendix 10B
Contents of circular for transactions

-
- (ix) the net assets per share;
 - (x) the current ratio;
 - (xi) total borrowings (all interest-bearing debts); and
 - (xii) the gearing ratio.
- (l) the commentary on past performance, which should include analysis and/or discussion of -
- (i) significant and specific factors contributing to exceptional performance in any of the financial years under review and significant changes in the financial performance on a year-to-year basis, whether favourable or adverse;
 - (ii) accounting policies adopted which are peculiar to the ~~company~~corporation/ business because of the nature of the business or the industry it involves in, as well as the effects of such policies on the determination of income or financial position; and
 - (iii) any audit qualification for the financial statements in any of the financial years under review; and
- (m) the latest audited financial statements together with the notes and the auditors' report (not required if accountant's report is provided).³
- (29) Where the percentage ratio is 50% or more, a directors' report on the unlisted ~~company~~corporation to be acquired.³
- (30) An appendix containing the following information:
- (a) a responsibility statement by the directors that the circular has been seen and approved by the directors of the listed issuer and that they collectively and individually accept full responsibility for the accuracy of the information given and confirm that after making all reasonable enquiries to the best of their knowledge and belief there are no other facts the omission of which would make any statement in the circular misleading;
 - (b) details of material commitments and contingent liabilities incurred or known to be incurred by the listed issuer;
 - (c) where a person is named in the circular as having advised the listed issuer or its directors, a statement -
 - (i) that such adviser has given and has not withdrawn its written consent to the inclusion of the adviser's name and/or letter (if applicable) in the form and context in which it is included; and
 - (ii) by the adviser as to whether conflict of interests exists or is likely to exist in relation to its role as an adviser. If a conflict of interests exists or likely to exist in relation to its role as an adviser, to provide full disclosure of the nature and extent of the conflict of interests or potential conflict of interests, the parties to the conflict, and measures taken for resolving, eliminating, or mitigating the situations of conflict of interests.

Appendix 10B
Contents of circular for transactions

For this purposes, “**conflict of interests**” means circumstances or relationships which affect or may affect the ability of the adviser to act independently and objectively or where the adviser has an interest in the outcome of the proposal which interferes or is likely to interfere with its independence and objectivity;

- (d) a statement of all material contracts (not being contracts entered into in the ordinary course of business) entered into by the ~~company corporation~~ to be acquired or disposed of and the ~~company corporation~~ whose shares or convertible securities are to be issued as consideration for the disposal by the listed issuer within 2 years immediately preceding the date of the circular. The following particulars must be disclosed in respect of each such contract:
- (i) the date of the contract;
 - (ii) the parties of the contract;
 - (iii) the general nature; and
 - (iv) the consideration and mode of satisfaction-;
- (e) a statement of all material litigation, claims or arbitration involving the ~~company corporation~~/assets to be acquired or disposed of and the ~~company corporation~~ whose shares or convertible securities are to be issued as consideration for the disposal by the listed issuer including those pending or threatened against such ~~companies corporations~~. The following information must be disclosed:
- (i) the background;
 - (ii) the date of the suit,
 - (iii) the names of the plaintiff(s) and defendant(s),
 - (iv) the estimate, of the maximum exposure to liabilities;
 - (v) the directors/solicitors’ opinion of the outcome; and
 - (vi) the status;
- (f) a statement that for a period from the date of the circular to the date of the extraordinary general meeting, the following documents (or copies of the documents) in respect of the listed issuer, the ~~company corporation~~ which is the subject of the transaction, and the ~~company corporation~~ whose shares or convertible securities are to be issued as consideration for the disposal by the listed issuer, where applicable, may be inspected at the registered office of the listed issuer -
- (i) the memorandum and articles of association;
 - (ii) the audited financial statements for each of the 2 financial years preceding the publication of the circular and the latest unaudited results since the last audited financial statements;
 - (iii) all reports, letters or other documents, balance sheets, valuations and statements by any adviser, any part of which is extracted or referred to in the circular;

Appendix 10B
Contents of circular for transactions

- (iv) the letters of consent referred to in subparagraph (c) above;
 - (v) the material contracts referred to in subparagraph (d) above; and
 - (vi) the relevant cause papers in respect of material litigation referred to in subparagraph (e) above ~~;~~ ~~and~~
- (31) Any other information which the security holders and their advisers would reasonably expect to find in a circular of that nature for the purpose of making an informed decision.

Part B**Additional specific information to be included in circular to shareholders in relation to joint-ventures**

- (1) The details of the joint-venture partners ~~;~~ ~~;~~
- (2) The authorised and current issued and paid-up capital ~~;~~ ~~;~~
- (3) The terms of the joint-venture agreement ~~;~~ ~~;~~
- (4) The breakdown of the total capital and investment outlay in the joint-venture ~~;~~ ~~;~~
- (5) The eventual issued and paid-up capital of the joint-venture ~~company corporation;~~ ~~;~~
- (6) The number, type, par value of the shares making up the share capital. Where there is more than one type of shares or securities issued, the following:
 - (a) the differences between the different types of shares or securities;
 - (b) whether convertible; if so, the rate and period ;
 - (c) whether redeemable; if so, the rate and period ; and
 - (d) the tenure ~~;~~ ~~;~~
- (7) The equity interest held by the respective parties ~~;~~ ~~;~~
- (8) The name of the joint-venture ~~company corporation;~~ ~~;~~
- (9) The source(s) of funds for financing the investment in the joint-venture ~~company corporation,~~ ~~and the breakdown;~~ ~~;~~ ~~and~~
- (10) If no joint-venture ~~company corporation~~ will be set up, the terms of cost and profit sharing and the estimated total cost of project.

Part C**Additional specific information to be included in relation to a transaction which involves an acquisition or disposal of real estate**

- (1) A description of each real estate including -

Appendix 10B
Contents of circular for transactions

-
- (a) the postal address or identification (lot, title number, relevant mukim, district and state) of the real estate;
 - (b) a brief description (e.g. whether land or building, approximate area, etc.);
 - (c) the existing and proposed use (e.g. shops, offices, factories, residential, or vacant etc.); if currently let out or is proposed to be let out, the details of the rentals and the rental income or expected rental income per month or per annum. If the real estate to be disposed is currently used as a factory, the effect of a disposal on the operations;
 - (d) the approximate age of the buildings;
 - (e) the terms of the tenure; if leasehold, the expiry date of the lease;
 - (f) a valuation certificate which must comply with the SC's Asset Valuation Guidelines. The valuation report and valuation certificate must be made available for inspection;
 - (g) a quantification of the market value of the real estate as appraised by the independent registered valuer;
 - (h) the net book value based on the latest audited financial statements; and
 - (i) the encumbrances, if any.
- (2) If the real estate acquired or disposed of is an estate or plantation, the following additional information:
- (a) the present and future usage;
 - (b) the type of estate or plantation;
 - (c) the maturity of the trees;
 - (d) the production for the past 3 years; and
 - (e) the profit contribution or revenue and expense account of the estate for the past 3 years.
- (3) Where the ~~assets~~ real estate to be acquired or disposed of consist of buildings the following additional information:
- (a) the number of storeys, gross built-up and net lettable or useable areas;
 - (b) the area to be self-occupied and let out respectively; and
 - (c) the percentage of occupancy.
- (4) Where the real estate is in the process of being or is intended to be developed, the following additional details:
- (a) the details of development potential, i.e. name of the project, type of development - residential, industrial or commercial, number of units in respect of each type of development;

Appendix 10B
Contents of circular for transactions

- (b) the total development cost;
- (c) the expected commencement and completion date(s) of development;
- (d) the expected profits to be derived;
- (e) the stage or percentage of completion;
- (f) the sources of funds to finance the development cost;
- (g) whether relevant approvals for the development have been obtained and date(s) obtained;
- (h) whether for sale or rental. If for sale, the percentage of sales or number of units sold to-date. If for rental, the expected rental income per annum; and
- (i) whether planning consent has been obtained and if so, whether there are any conditions attached to such consent.

Part D

Additional specific information to be included in relation to acquisitions or disposals of construction ~~companies~~corporations

- (1) A description of current projects undertaken by the ~~corporation~~company - date of award, type of construction, name of the project, owner of the project, location of the project and value.;
- (2) The expected commencement and completion date(s) of construction of projects on hand or in progress.;
- (3) A description of recent major projects completed - date of commencement and completion of construction, type of construction, contract value and project owner.;
- ~~and~~
- (4) A confirmation on whether the project owner is a director, substantial shareholder of the acquiree ~~company~~corporation or persons connected with them in respect of current and past projects undertaken/ completed.

Part E

Additional specific information to be included in relation to acquisitions or disposals of infrastructure project asset/business or corporations involved in infrastructure projects

- (1) The pertinent details of the concession/license, including but not limited to -
 - (a) nature of the concession/license (e.g. Build-Operate-Transfer, Build-Transfer-Operate, Build-Own-Operate, etc.);
 - (b) life/duration and exclusivity/non-exclusivity of the concession/license;
 - (c) salient terms and conditions of the concession/license;
 - (d) infrastructure project ~~corporation~~company's rights, interest and major obligations under the concession/license; and

Appendix 10B
Contents of circular for transactions

-
- (e) acts/regulations under which the concession/license is granted.†
 - (2) The nature of relationship with concession giver/licensor.†
 - (3) The details of any construction risk.†
 - (4) The dependence on concession giver/ licensor.† and
 - (5) The details of financing requirements and sources of funding.

Part F**Additional specific information to be included in relation to foreign acquisitions where any one of the percentage ratios is 25% or more**

- (1) The expert's report on policies on the foreign investments, taxation and repatriation of profits of the host country.†
- (2) Where an accountant's report is required pursuant to Part G of this Appendix, the report must be prepared by a firm of public accountants registered in Malaysia, in accordance with the approved accounting standards of the Malaysian Accounting Standards Board.†
- (3) A valuation report on the foreign assets proposed to be acquired prepared by a qualified valuer, the appointment of which complies with the SC's Asset Valuation Guidelines in relation to the appointment of valuer for valuation of foreign property assets.†
- (4) The expert's report, prepared by industry experts, on the fairness of the total purchase consideration for the foreign securities or assets proposed to be acquired.† and
- (5) A legal opinion from a reputable law firm on -
 - (a) the ownership of title to the securities or assets in the foreign jurisdiction;
 - (b) the enforceability of agreements, representations and undertakings given by foreign counter-parties under relevant laws of domicile; and
 - (c) other relevant legal matters.

Part G**Additional specific information to be included in relation to very substantial transactions**

(paragraph 10.10)

- (1) The proforma consolidated balance sheets together with the notes and the auditors' letter showing effects before and after the transaction based on the listed issuer's -
 - (a) published or announced audited financial statements for the latest financial period ended; or
 - (b) latest published or announced interim financial report which must be reviewed by external auditors.

Appendix 10B
Contents of circular for transactions

Where an interim report referred to in subparagraph 1(b) above is used, a statement that the interim report has been reviewed by external auditors.;

- (2) A summary of the key audited financial data of the assets of business or interests to be acquired for the past 3 financial years or since the date of incorporation or commencement of operations, whichever is the later. The financial data must include, but not be limited to, shareholders' funds and total borrowings.;
- (3) An accountant's report on the unlisted ~~corporation~~ company to be acquired which must include the following:
 - (a) the income statement in respect of each of the 3 financial years immediately preceding the last date to which the financial statements were made up; and
 - (b) the balance sheet for each of the past 3 financial years immediately preceding the last date to which the financial statements were made up;
- (4) For assets or interests to be acquired which do not have any profitability track record (as in certain privatisation cases), the information must include, but not be limited to, the total cost needed to put on-stream the operation of the assets or interests and the proportion to be assumed or guaranteed by the listed issuer, the expected date on which the profit contribution will accrue to the listed issuer and the expected returns to be derived, together with the appropriate assumptions used. The listed issuer must ensure that the information provided is verified and confirmed by independent experts.;
- (5) In the case of a disposal, a statement on the listed issuer's future activities and direction after the disposal of the asset.

Part H**Additional specific information to be included in relation to significant change in business direction or policy of a listed corporation**

(paragraph 10.11 and 10.14)

- (1) The following statements to be stated on the cover page of the circular:

"The Securities Commission has approved the proposal contained in this circular. The approval should not be taken to indicate that the Securities Commission recommends the proposal or assumes responsibility for the correctness of any statement made or opinion or report expressed in this circular. The Securities Commission has not, in any way, considered the merits of the proposal being tabled for shareholders' approval."

"The Securities Commission is not liable for any non-disclosure on the part of the corporation and takes no responsibility for the contents of this document, makes no representation as to its accuracy or completeness, and expressly disclaims any liability for any loss you may suffer arising from or in reliance upon the whole or any part of the contents of this circular."
- (2) If the transaction results in a change in the controlling shareholder(s) of the listed issuer, the following information in respect of the new controlling shareholder(s), where applicable:
 - (a) the name;

Appendix 10B
Contents of circular for transactions

-
- (b) the date and place of incorporation;
 - (c) the names of directors and substantial shareholders and their respective shareholdings;
 - (d) the common directorships and controlling shareholdings in other listed issuers;
 - (e) the principal business;
 - (f) qualification and experience of the new controlling shareholder, if the new controlling shareholder is an individual; and
 - (g) the new controlling shareholder(s)' interest in all other ~~companies~~ corporations or businesses, principal activities of such ~~companies~~ corporations or nature of such businesses. If a conflict of interests exists or likely to exist, to provide full disclosure of the nature and extent of the conflicts of interests or potential conflicts of interests, the parties to the conflicts, and measures taken for resolving, eliminating, or mitigating the situations of conflict of interests.
- (3) If the transaction results in a change in the board of directors of the listed corporation, the following information in respect of the new board of directors:
- (a) name and nationality;
 - (b) occupation and qualification;
 - (c) profile, including designation, function and business and management expertise; and
 - ~~(d)~~ the new director's interest in all other ~~companies~~ corporations or businesses, principal activities of such ~~companies~~ corporations or nature of such businesses. If a conflict of interests exists or likely to exist, to provide full disclosure of the nature and extent of the conflicts of interests or potential conflicts of interests, the parties to the conflicts, and measures taken for resolving, eliminating, or mitigating the situations of conflict of interests.
- (4) Changes in the substantial shareholders in the assets or interests to be acquired over the past 3 years.
- (5) Background of the vendors whom are substantial shareholders ("**Vendor**") of the assets or interests to be acquired, where applicable:
- ~~(i)~~ name;
 - ~~(ii)~~ date and place of incorporation;
 - ~~(iii)~~ principal activities;
 - ~~(iv)~~ substantial shareholders and directors of the Vendors and their respective shareholdings; and
 - ~~(v)~~ occupation, qualification and experience of the Vendors; and

Appendix 10B
Contents of circular for transactions

-
- (6) A summary of the key audited financial data of the assets or interests to be acquired for the past 3 to 5 financial years based on audited financial statements (depending on the profit track record used for compliance with the SC's Equity Guidelines) or since the date of incorporation or commencement of operations, whichever is the later. The financial data must include, but not be limited to, the items mentioned in paragraph 28(k) of Part A above.;
- (7) An accountant's report on the unlisted ~~company corporation~~ to be acquired which must include the following:
- (a) the income statement in respect of each of the 3 to 5 financial years (depending on the profit track record used for compliance with the SC's Equity Guidelines) immediately preceding the last date to which the financial statements were made up; and
 - (b) the balance sheet for each of the past 3 to 5 financial years (depending on the profit track record used for compliance with the SC's Equity Guidelines) immediately preceding the last date to which the financial statements were made up.
- (8) The proforma consolidated balance sheets together with the notes and the auditors' letter showing effects before and after the transaction based on the listed issuer's -
- (a) published or announced audited accounts for the latest financial period ended; or
 - (b) latest published or announced interim financial report which must be reviewed by external auditors.
- Where an interim report referred to in subparagraph (b) above is used, a statement that the interim report has been reviewed by external auditors.;
- (9) For assets or interests which do not have any profitability track record (as in certain privatisation cases), the information must include, but not be limited to, the total cost needed to put on-stream the operation of the assets or interests and the proportion to be assumed or guaranteed by the listed issuer, the expected date on which the profit contribution will accrue to the listed issuer and the expected returns to be derived, together with the appropriate assumptions used. Information provided should be verified and confirmed by independent experts.
- (10) Qualitative assessment of each asset/ interest to be acquired as follows:
- (a) analysis of the quality of the products, services, applications, significant recent trends in demand and production, sales and inventory and state of the current order book.;
 - (b) product/services diversity, quality and whether deemed a necessity or luxury.;
 - Level of gearing, liquidity and working capital requirements.;
 - Market access, market share/ ranking/ reputation.;
 - Competitive advantage in terms of operations, technology, pricing, financing etc.;
 - Details of long term contracts, availability of resources, capability to diversify, sensitivity to economic downturn, business, operational, financial, and investment risks.;
 - (c) information of customer and supplier base including number of customers/ suppliers, length of relationship and dependency on major customers/ suppliers and mitigating factors.;

Appendix 10B
Contents of circular for transactions

-
- (d) description of industry/-sector (including size), past and present performance, growth prospects, industry players and competition, demand/—supply conditions, level of market saturation in terms of players and/—or products, relevant laws and regulation governing the industry/-sector.
 - (11) A thorough discussion and analysis of the business, financial conditions and prospects of the assets or interests to be acquired or where applicable, those of its group. Such discussion and analysis must contain, at the minimum, the information required under the section on Management's Discussion and Analysis of Financial Condition, Results of Operations and Prospects of Chapter 12 of the SC's Prospectus Guidelines.
 - (12) If the asset is infrastructure project asset/business or corporations involved in infrastructure projects, to provide information as required under Chapter 19 of the SC's Prospectus Guidelines.

Part I**Additional specific information to be included in relation to qualifying acquisition of a Special Purpose Acquisition Company**

(paragraph 10.14)

- (1) Details of all credit facilities entered into by the SPAC, and the proposed utilisation of funds. Details of the credit facility must include, amongst others, the salient terms of the facility and details of any security provided.
- (2) Aggregate fair market value of the qualifying acquisition(s) in monetary terms and as a percentage of the aggregate amount then on deposit in the trust account (net of any taxes payable).
- (3) Terms and procedures of the liquidation distribution upon failure to meet the timeframe for the qualifying acquisition. -This should also include the situation where the qualifying acquisition has been approved by shareholders but fails to be completed on time.
- (4) Voting and conversion options available to the shareholder in relation to the qualifying acquisition should be clearly disclosed.

[End of Appendix]

Appendix 10C
Additional contents of announcement
for related party transactions

APPENDIX 10C**Additional contents of announcement in relation to related party transactions**

(paragraphs 10.08(1) and 10.08(11)(i) and (j))

- (1) If the transaction requires the prior shareholder approval, a statement that the director, major shareholder and/or person connected with a director or major shareholder, which have any interest, direct or indirect, in the transaction will abstain from voting in respect of their direct and/or indirect shareholdings. Where the person connected with a director or major shareholder has interest, direct or indirect, in the transaction, a statement that the director or major shareholder concerned will also abstain from voting in respect of his direct and/or indirect shareholdings. Further, a statement that such interested director and/or major shareholder—_has/have undertaken that he/they will ensure that the persons connected with him/them will abstain from voting on the resolution approving the issue at the general meeting. In the case of an interested director, a statement that the interested director has abstained and/or abstain from deliberating and voting on the relevant resolution at the board meeting.
- (2) If the listed issuer is required to appoint an independent adviser, a statement explaining the role of the independent adviser.
- (3) A statement setting out the following:
 - (a) whether the audit committee of the listed issuer is of the view that the transaction is -
 - (i) in the best interest of the listed issuer;
 - (ii) fair, reasonable and on normal commercial terms; and
 - (iii) not detrimental to the interest of the minority shareholders,together with the basis for its views;
 - (b) where the audit committee has sought an independent advice in forming its views, a statement to that effect; and
 - (c) where the views of the audit committee are different from the opinion of the independent adviser, if any, the reasons for the difference. ~~;~~ **and**
- (4) In relation to a transaction which falls within paragraph 10.08(9), a statement by the board of directors of the listed issuer setting out the following:
 - (a) whether the board or directors is of the view that the transaction is -
 - (i) in the best interest of the listed issuer;
 - (ii) fair, reasonable and on normal commercial terms; and
 - (iii) not detrimental to the interest of the minority shareholders,together with the basis for its views (collectively referred to as “**Statement**”); ~~;~~

Appendix 10C
Additional contents of announcement
for related party transactions

- (b) where the board of directors has sought an independent advice in forming its views, a statement to that effect;
 - (c) where the views of the board of directors are different from the opinion of the audit committee or independent adviser (if any) the reasons for the difference; and
 - (d) where a director disagrees with the Statement, a statement by the director setting out the reasons and the factors taken into consideration in forming that opinion.
- (5) In the case of an acquisition, the original cost of investment to the vendor and the date of such investment.
- (6) The total amount transacted with the same related party for the preceding 12 months.

[End of Appendix]

Appendix 10D
Additional contents of circular
for related party transactions

APPENDIX 10D**Additional contents of circular to shareholders in relation to related party transactions**
(paragraph 10.08(2)(a))

- (1) The interested parties' direct and indirect shareholdings in the listed issuer.
- (2) A statement that the interested directors have abstained and/or will abstain from board deliberation and voting on the relevant resolution.
- (3) A statement that the director, major shareholder and/or person connected with a director or major shareholder, which have any interest, direct or indirect, in the transaction will abstain from voting in respect of their direct and/or indirect shareholdings. Where the person connected with a director or major shareholder has interest, direct or indirect, in the transaction, a statement that the director or major shareholder concerned will also abstain from voting in respect of his direct and/or indirect shareholdings. Further, a statement that such interested director and/or major shareholder has/have undertaken that he/they will ensure that the persons connected with him/them abstain from voting on the resolution approving the issue at the general meeting.
- (4) The total amount transacted with the same related party for the preceding 12 months.
- (5) A separate letter by an independent adviser incorporating -
 - (a) an opinion as to whether the transaction is fair and reasonable so far as the shareholders are concerned and whether the transaction is to the detriment of minority shareholders and, such opinion must set out the reasons for, the key assumptions made and the factors taken into consideration, in forming that opinion; and
 - (b) advice to minority shareholders on whether they should vote in favour of the transaction.
- (6) A statement setting out whether the audit committee of the listed issuer is of the view that the transaction is -
 - (a) in the best interest of the listed issuer;
 - (b) fair, reasonable and on normal commercial terms; and
 - (c) not detrimental to the interest of the minority shareholders,
together with the basis for its views.

[_End of Appendix]

CHAPTER 11 TAKE-OVERS AND MERGERS**PART A - GENERAL****11.01 Introduction**

- (1) This Chapter sets out the disclosure requirements that must be complied with in relation to a take-over of a listed corporation.
- (2) Where an offeror is not a listed corporation but makes a take-over offer on a listed corporation or any of its subsidiaries, the offeror must comply with the relevant requirements in this Chapter.

PART B - DEFINITIONS**11.02 Definitions**

For the purpose of this Chapter, unless the context otherwise requires, the words or expressions defined in the Take-Overs and Mergers Code and section 216 of the CMSA when used in this Chapter, have the meanings given under the Take-Overs and Mergers Code and [the CMSA](#).

PART C - GENERAL REQUIREMENTS**11.03 Secrecy during discussion stage**

Where discussions are ongoing between a listed corporation and a corporation, person or group which may lead to an offer being made, the directors, officers and advisers of both parties must do everything possible to maintain secrecy in order to avoid disturbance in the price level of the shares.

11.04 Immediate announcement of notice of take-over offer

Where a person sends a written notice of a take-over offer in relation to securities or voting shares which are listed pursuant to [subsection 12\(2\)](#) or [paragraph \(a\) of subsection 12\(3\)\(a\)](#) of the Take-Overs and Mergers Code, such person must immediately announce such notice to the Exchange. Such person must include in the announcement the information set out in Part A of Appendix 11A.

11.05 Immediate announcement of notice received and acceptance of take-over offer

Where a listed corporation receives a notice of intention to make a take-over offer, the directors must immediately announce such notice to the Exchange. The listed corporation must include in the announcement the information set out in Part B of Appendix 11A.

11.06 Documents to be sent to all classes of securities

An offeree must send to all holders of other classes of shares and convertible securities of the listed corporation, whether or not such securities are covered by the take-over offer, a copy of all documents which ~~it~~ is required by law to be sent to the holders of the shares and convertible securities subject to the take-over offer.

11.07 Announcements of dealings by offeror, etc. during offer period

- (1) Subject to subparagraph (2) below, the following persons must immediately announce to the Exchange the total number and price of all voting shares in the offeror and the offeree which are dealt in for their own account during the offer period, not later than 12.00 ~~p.m.~~noon on the market day following the date of the relevant transaction:
- (a) the offeror, the offeree and all persons acting in concert with the offeror;
 - (b) a substantial shareholder of the offeree or in the case of a securities exchange offer, a substantial shareholder of the offeror. For the purpose of this paragraph, a “**substantial shareholder**” means a person who has an interest or interests in one or more voting shares of the corporation and the nominal amount of that voting share, or the aggregate of the nominal amount of those voting shares, is not less than 5% of the aggregate of the nominal amounts of all the voting shares of the corporation;
 - (c) any chief executive, a director or an officer of the offeror or offeree who occupies or acts in a senior managerial position in the offeror or offeree, by whatever name called and whether or not he is a director;
 - (d) a person who is a connected person in relation to persons referred to in subparagraphs (a), (b) or (c) above; and
 - (e) a person who is accustomed to act in accordance with directions or instructions of the persons referred to in subparagraphs (a), (b), (c) or (d) above.
- (2) All dealings in voting shares in the offeror or the offeree made by a connected person for the account of investment clients who are not themselves connected persons must be disclosed to the Exchange. ~~but~~However, these announcements are not for public release and ~~such announcements~~ must be marked “Not for Public Release Unless Approved by the Securities Commission”.

11.08 Announcement of acceptances

An offeror must immediately announce to the Exchange the total number of voting shares to which the take-over offer relates -

- (a) for which acceptances of the take-over offer have been received after the posting of the offer document by the offeror to offeree shareholders;
- (b) held by the offeror and all persons acting in concert with the offeror at the time of posting of the offer document to offeree shareholders; and
- (c) acquired or agreed to be acquired during the offer period,

and should specify the percentages of the relevant classes of share capital represented by these figures before 9.00 a.m. following the day on which the take-over offer is closed, becomes or is declared unconditional as to acceptances, revised or extended, whichever is the earlier.

PART D - ADDITIONAL REQUIREMENTS**11.09 Equity structure to be furnished to Exchange upon completion of take-over**

Upon completion of the take-over offer of a listed corporation, the listed corporation must, in addition to complying with paragraph 8.02(1), furnish a schedule of the listed corporation's securities to the Exchange in the following format:

<i>Particulars</i>	<i>No of shares</i>	<i>No of shareholders</i>	<i>Percentage %</i>
<i>Issued and paid-up capital</i>			
<i>Less:</i>			
<i>treasury shares</i>			
<i>Directors of the listed corporation and its subsidiaries and/or associated companies</i>			
<i>Substantial shareholders of the listed corporation (except where such shareholder may be included as "public")</i>			
<i>Associates of directors or substantial shareholders of the listed corporation</i>			
<i>Shareholders holding less than 100 shares</i>	-----		
<i>Public shareholdings</i>			

11.10 Offeror to announce plans and intentions with regard to the offeree

Where an unlisted corporation, person or group submits a take-over offer for the acquisition of a listed corporation's securities, ~~upon the announcement by the offeror~~ must immediately announce to the Exchange, when the offeror, that he has obtained sufficient acceptances and that he holds directly or indirectly, holds more than 50% of the offeree's securities, ~~the offeror must immediately announce to the Exchange, his plans and intentions with regard to the offeree and any other information that the Exchange considers necessary.~~

11.11 Requirements of Chapter 10 on acquisitions to be complied with

Where an offeror is a listed corporation the requirements of Chapter 10 must be complied with.

[End of Chapter]

Appendix 11A
Contents of announcement in relation to a take-over offer

APPENDIX 11A**Part A****Contents of announcement in relation to a notice of a take-over offer**

(paragraph 11.04)

- (1) The identity of the proposed offeror and all persons acting in concert with the proposed offeror.;
- (2) The terms and conditions of the take-over offer.;
- (3) The type and total number of voting shares of the corporation -
 - (a) which has been acquired, held or controlled directly or indirectly by the proposed offeror or any person acting in concert with the proposed offeror;
 - (b) in respect of which the proposed offeror or any person acting in concert with the proposed offeror have received an irrevocable undertaking from other holders of voting shares to which the take-over relates to accept the take-over offer; and
 - (c) in respect of which the proposed offeror or any person acting in concert with the proposed offeror has an option to acquire.;
- (4) The details of any existing or proposed agreement, arrangement or understanding relating to voting shares referred to in paragraph (3) above between the proposed offeror or any person acting in concert with the proposed offeror and the holders of the voting shares to which the take-over relates.;
- (5) The conditions of the take-over offer, including conditions relating to acceptances, listing and increase of capital.

Part B**Contents of announcement in relation to the receipt of notice of intention to make a take-over offer**

(paragraph 11.05)

- (1) All the information disclosed to the board of directors of the offeree in the written notice that it has received under subsection 12(2) or ~~paragraph (a) of subsection 12(3)(a)~~ of the Take-Overs and Mergers Code.;
- (2) A statement whether the board of directors of the offeree is seeking an alternative person to make a take-over offer of its voting shares.

[End of Appendix]

CHAPTER 12 SHARE BUY-BACKS**PART A - GENERAL****12.01 Introduction**

This Chapter sets out the requirements that must be complied with by a listed corporation in respect of the purchase of the listed corporation's own shares.

PART B - DEFINITIONS**12.02 Definitions**

For the purpose of this Chapter, unless the context otherwise requires, "on the market" transactions means transactions made through the Automated Trading System ("ATS") of the Exchange and excludes "Direct Business" transactions as defined in the Rules of the Exchange.

PART C - GENERAL REQUIREMENTS**12.03 Authorisation**

A listed corporation must not purchase its own shares unless ~~the-its~~ shareholders ~~of the-listed corporation~~ have given an authorisation to the directors of the listed corporation to make such purchase(s) by way of ordinary resolution which has been passed at a general meeting and subject to ~~the provisions of~~ section 67A of the Companies Act 1965 and Part IIIA of the Companies Regulations 1966.

12.04 On the market transactions

~~Subject to paragraph 12.25(1) below, A~~ listed corporation must ensure that any purchase by a listed corporation of its own shares, or resale of its treasury shares is effected only on the market of the Exchange.

12.05 Announcement of intention to propose a share buyback

A listed corporation must immediately announce to the Exchange any decision by the board of directors of the listed corporation to submit to shareholders a proposal for the listed corporation to be authorised to purchase its own shares.

12.06 Circular to shareholders for purchase of own shares

- (1) A listed corporation seeking authorisation from its shareholders to purchase its own shares other than by way of a renewal of an existing authorisation, must issue a circular to its shareholders that complies with the requirements of subparagraph (3) below.
- (2) A listed corporation that is renewing its existing authorisation must either issue -
 - (a) a statement accompanying its notice of general meeting ("**Share Buy-back Statement**"), in substitution of the circular; or
 - (b) a circular, as referred to in subparagraph (1) above.

Where a listed corporation issues a Share Buy-back Statement, it must ensure that such Statement complies with the requirements of subparagraph (4) below.

-
- (3) The listed corporation must include in the circular referred to under subparagraph (1) above the information set out in Part A of Appendix 12A and all such information concerning the proposed purchase as shareholders and their advisers would reasonably require and would reasonably expect to find in the circular for the purposes of making an informed assessment as to the merits of approving the proposed purchase and the extent of the risks involved in doing so.
 - (4) The listed corporation must include in the Share Buy-back Statement the information set out in Part B of Appendix 12A and all such information concerning the proposed purchase as shareholders and their advisers would reasonably require and would reasonably expect to find in the Share Buy-back Statement for the purposes of making an informed assessment as to the merits of approving the proposed purchase and the extent of the risks involved in doing so.
 - (5) The listed corporation must submit the circular or Share Buy-back Statement, as the case may be, to the Exchange together with a checklist showing compliance with Part A or B of Appendix 12A respectively.

12.07 Contents of ordinary resolution for share buy-back

- (1) A listed corporation must include in the ordinary resolution required under paragraph 12.03 for a listed corporation to purchase its own shares the information set out in Appendix 12B.
- (2) The listed corporation must submit the resolution to the Exchange together with a checklist showing compliance with Appendix 12B.
- (3) Any authority conferred by such resolution may only continue to be in force until -
 - (a) the conclusion of the first annual general meeting of the listed corporation following the general meeting at which such resolution was passed at which time it will lapse unless by ordinary resolution passed at that meeting, the authority is renewed, either unconditionally or subject to conditions;
 - (b) the expiration of the period within which the next annual general meeting after that date is required by law to be held; or
 - (c) revoked or varied by ordinary resolution passed by the shareholders in general meeting,whichever occurs first.

12.08 Announcement of outcome of general meeting

A listed corporation must immediately announce to the Exchange the outcome of the general meeting called to consider the proposed purchase of its own shares on the Exchange, immediately following such meeting.

12.09 Maximum limit

A listed corporation must not purchase its own shares or hold any of its own shares as treasury shares if this results in the aggregate of the shares purchased or held exceeding 10% of its issued and paid-up capital.

PART D - SOURCE OF FUNDS AND CONSIDERATION**12.10 Source of funds**

- (1) A listed issuer must ensure that the proposed purchase(s) of its own shares is made wholly out of retained profits or the share premium account of the listed corporation or both.
- (2) For the purpose of calculating the total amount of retained profits or share premium available for effecting a share buy-back, the listed corporation must not use the amount of retained profits and share premium available on a group basis.

12.11 Types of funds

For the purpose of paragraph 12.10, there are no restrictions on the types of funds which can be utilised so long as the share buy-back is backed by an equivalent amount of retained profits or share premium. The use of borrowings as a funding source is entirely within the ambit envisaged by this Chapter.

PART E - DECLARATION OF SOLVENCY**12.12 Declaration of solvency**

A listed corporation must ensure that a solvency declaration is lodged with the Exchange by the directors of the listed corporation as follows:

- (a) where it is incorporated under the Companies Act 1965, in accordance with section 67A of the Companies Act 1965 and Part IIIA of the Companies Regulations 1966; or
- (b) where it is a foreign corporation, in the form and manner prescribed under Part IIIA of the Companies Regulations 1966 subject to the necessary modifications.

12.13 Execution of solvency declaration

- (1) The solvency declaration must be signed and dated by the majority of the directors.
- (2) If any director, whether or not that director signed the declaration, is of the opinion that it is likely that the listed corporation will not remain solvent at the time of the relevant purchase(s), the director must immediately notify the board of directors of the listed corporation in writing and lodge a copy of such notice with the Exchange and the giving of such notice will revoke the validity of the earlier solvency declaration.

PART F - ADDITIONAL REQUIREMENTS**12.14 Public shareholding**

A listed corporation must not purchase its own shares on the Exchange if that purchase(s) will result in the listed corporation being in breach of paragraph 8.02(1).

12.15 Appointment of stockbroker

A listed corporation intending to purchase its own shares or resell treasury shares on the Exchange may appoint up to 2 Participating Organisations for that purpose. The listed corporation must ensure that all dealing(s) in its own shares or treasury shares are made through the said Participating Organisations only.

12.16 Notice of appointment of stockbroker

A listed corporation must lodge a notice of the appointment of the Participating Organisations concerned with the Exchange immediately and the listed corporation must open one securities account in its own name with such Participating Organisations designated as "Share Buy-Back Account" which must solely be used for the purchase of its own shares or resale of treasury shares.

12.17 Purchase price

A listed corporation may only purchase its own shares on the Exchange at a price which is not more than 15% above the weighted average market price for the shares for the 5 market days immediately before the purchase.

12.18 Resale price

A listed corporation may only resell treasury shares on the Exchange at -

- (a) a price which is not less than the weighted average market price for the shares for the 5 market days immediately before the resale; or
- (b) a discounted price of not more than 5% to the weighted average market price for the shares for the 5 market days immediately before the resale provided that -
 - (i) the resale takes place not earlier than 30 days from the date of purchase; and
 - (ii) the resale price is not less than the cost of purchase of the shares being resold.

12.19 Notification of purchase

A listed corporation must immediately announce to the Exchange any purchase(s) of its own shares not later than 6.30 p.m. on the day the purchase is made. The listed corporation must include in its announcement the information set out in Part A of Appendix 12C.

12.20 Notification of resale

A listed corporation must immediately announce to the Exchange any resale(s) of its treasury shares not later than 6.30 p.m. on the day the resale is made. The listed corporation must include in its announcement the information set out in Part B of Appendix 12C.

12.21 Notification of cancellation

A listed corporation must immediately announce to the Exchange any cancellation of its shares or treasury shares not later than 6.30 p.m. on the day the cancellation is made. The listed corporation must include in its announcement the information set out in Part C of Appendix 12C.

12.22 Exercise of powers

- (1) A listed corporation and its directors in exercising the power to purchase a listed corporation's own shares or resell treasury shares, are subject, at all times, to all such obligations imposed on them under the law, including but not limited to the provisions of Part V of the CMSA.
- (2) In exercising its power to purchase its own shares or resell treasury shares, a listed corporation must not engage in speculative trading activities in relation to such purchase or resale.

12.23 Information to be included in annual reports

A listed corporation must include in its annual report, information with respect to purchase of its own shares as set out in Appendix 12D.

12.24 Status of purchased shares

All shares which are purchased by the listed corporation will be automatically de-listed upon their cancellation by the listed corporation.

PART G - SPECIFIC REQUIREMENTS FOR SHARE BUY-BACK BY A SPECIAL PURPOSE ACQUISITION COMPANY**12.25 Share buy-back by a SPAC**

- (1) Notwithstanding paragraph 12.04, a SPAC may purchase its own shares through a "Direct Business" transaction as defined in the Rules of the Exchange, solely for the purpose of paying a pro rata portion of the amount held in the SPAC's Trust Account to holders of the voting securities who voted against the qualifying acquisition proposed to be undertaken by the SPAC in accordance with section 67A of the Companies Act 1965 and Part IIIA of the Companies Regulations 1966.
- (2) The following provisions are not applicable to a SPAC which purchases its own shares in accordance with subparagraph (1) above:
 - (a) paragraph 12.03;
 - (b) paragraph 12.04;
 - (c) paragraph 12.06;
 - (d) paragraph 12.07;
 - (e) paragraph 12.08;
 - (f) paragraph 12.09;
 - (g) paragraph 12.14, provided that the SPAC undertakes reasonable steps to comply with the spread requirement set out in paragraph 8.02;
 - (h) paragraph 12.17;
 - (i) paragraph 12.18; and
 - (j) paragraph 12.20.
- (3) A SPAC must immediately cancel all the shares it purchased pursuant to subparagraph (1) above and make an announcement pursuant to paragraph 12.21.
- (4) Except as provided in this paragraph 12.25, a SPAC must not purchase its own shares until it has fully paid or satisfied the consideration of the qualifying acquisition and the ownership of the assets acquired by the SPAC is beneficially and legally vested in the SPAC.

[End of Chapter]

Appendix 12A
Contents of circular & statement for share buy-back

APPENDIX 12A**Part A****Contents of circular in relation to a share buy-back**

(paragraph 12.06(3))

- (1) A heading drawing attention to the importance of the circular and advising holders of shares who are in any doubt as to what action to take to consult appropriate independent advisers.
- (2) A statement that Bursa Malaysia Securities Berhad takes no responsibility for the contents of the circular, makes no representation as to its accuracy or completeness and expressly disclaims any liability whatsoever for any loss howsoever arising from or in reliance upon the whole or any part of the contents of the document.
- (3) A statement with regard to the reasons for the proposed purchase.
- (4) The maximum number or percentage of shares to be acquired.
- (5) The total maximum amount of funds to be allocated for the proposed purchase or otherwise a basis, other than reference to any person's discretion or opinion, or a formula to determine the maximum fund that is to be allocated.
- (6) The amount of retained profits and share premium based on the latest audited financial statements and the latest management accounts (where applicable).
- (7) The number of shares held directly and indirectly by the directors and substantial shareholders.
- (8) The source of funds for the purpose of the proposed purchase including, where applicable, details relating to financing for the proposed purchase, the repayment capabilities of the listed corporation and the impact on its cash flow.
- (9) The direct and indirect interests of the directors and substantial shareholders and any person connected with the directors and/or substantial shareholders in the proposed purchase of shares or resale of treasury shares.
- (10) Both the potential advantages and disadvantages of the proposed purchase to the listed corporation and its shareholders respectively.
- (11) Any material financial effect on the listed corporation or group if the proposed purchase(s) were to be carried out in full at any time during the proposed authorised period (such as the working capital of the listed corporation as compared with the position disclosed in the most recent published or announced audited financial statements).
- (12) A statement as to the consequences of the proposed purchase on the listed corporation and its shareholders with regard to the Take-Over and Mergers Code or in relation to a foreign corporation, the relevant laws of the place of incorporation in respect of take-overs and mergers.
- (13) The details of any purchase made in the preceding 12 months giving the date of each purchase and the purchase price per share or the highest, lowest and average prices paid and total consideration paid for such purchase(s).

Appendix 12A
Contents of circular & statement for share buy-back

- (14) The details of number of shares currently held as treasury shares and of any resale of treasury shares made in the preceding 12 months giving the date of each resale and the resale price per share or the highest, lowest and average resale prices and total consideration received for such resale(s);
- (15) The details of any cancellation of shares made in the preceding 12 months;
- (16) The details of the highest and lowest prices at which the relevant shares were traded on the Exchange for the preceding 12 months and the last transacted price on the latest practicable date before printing the circular;
- (17) Whether it is the proposed intention of the directors to retain the shares as treasury shares or cancel them, or both, the rationale for the alternatives chosen and, if available, information as to the percentage or number of shares purchased which are to be retained and/or cancelled;
- (18) The public shareholding spread of the listed corporation, as at the latest practicable date;
- (19) A statement by the board of directors whether the proposal is in the best interest of the listed corporation;
- (20) A recommendation from the board of directors as to the voting action that shareholders should take;
- (21) An appendix containing the following information:
- (a) a responsibility statement by the directors that the circular has been seen and approved by the directors of the listed corporation and that they collectively and individually accept full responsibility for the accuracy of the information given and confirm that after making all reasonable enquiries to the best of their knowledge and belief, there are no other facts the omission of which would make any statement in the circular misleading;
 - (b) where a person is named in the circular as having advised the listed corporation or its directors, a statement that such adviser has given and has not withdrawn its written consent to the inclusion of the adviser's name and/or letter (where applicable) in the form and context in which it is included;
 - (c) a statement of all material contracts (not being contracts entered into in the ordinary course of business) entered into by the listed corporation and/or its subsidiaries within 2 years immediately preceding the date of the circular. The following particulars must be disclosed in respect of each such contract:
 - (i) the date of the contract;
 - (ii) the parties of the contract;
 - (iii) the general nature; and
 - (iv) the consideration and mode of satisfaction;
 - (d) a statement of all material litigation, claims or arbitration involving the listed corporation and/or any of its subsidiaries, including those pending or threatened against such companies/corporations. The following particulars must be disclosed:

Appendix 12A
Contents of circular & statement for share buy-back

- (i) the background;
 - (ii) the date of the suit;
 - (iii) the names of the plaintiff(s) and defendant(s);
 - (iv) the estimate of the maximum exposure to liabilities;
 - (v) ~~the~~ directors'/solicitors' opinion of the outcome; and
 - (vi) the status;
- (e) a statement that for a period of not less than 2 weeks following the publication of the circular, the following documents (or copies of the documents) may be inspected at the registered office of the listed corporation:
- (i) the memorandum and articles of association;
 - (ii) the audited financial statements of the listed corporation/group for the past 2 financial years and the latest unaudited results since the last audited financial statements;
 - (iii) all reports, letters or other documents, balance sheets, valuations and statements by any expert, any part of which is extracted or referred to in the circular;
 - (iv) the letters of consent referred to in subparagraph (b) above;
 - (v) the material contracts referred to in subparagraph (c) above; and
 - (vi) the relevant cause papers in respect of material litigation referred to in subparagraph (d) above. ~~;~~ ~~and~~
- (22) Any other information concerning the proposed purchase as shareholders and their advisers would reasonably require and would reasonably expect to find in the circular for the purposes of making an informed assessment as to the merits of approving the proposed purchase and the extent of the risks involved in doing so.

Part B**Contents of Share Buy-back Statement**

(paragraph 12.06(4))

- (1) A statement that Bursa Malaysia Securities Berhad takes no responsibility for the contents of the statement, makes no representation as to its accuracy or completeness and expressly disclaims any liability whatsoever for any loss howsoever arising from or in reliance upon the whole or any part of the contents of the document. ~~;~~
- (2) A statement with regard to the reasons for the proposed purchase. ~~;~~
- (3) The amount of retained profits and share premium based on the latest annual audited financial statements and the latest management accounts (where applicable). ~~;~~

Appendix 12A
Contents of circular & statement for share buy-back

- (4) The source of funds for the proposed purchase, including where applicable, details relating to financing for the proposed purchase, the repayment capabilities of the listed corporation and the impact on its cash flow.;
- (5) The direct and indirect interests of the directors and substantial shareholders and any person connected with the directors and/or substantial shareholders in the proposed purchase of shares or resale of treasury shares.;
- (6) Both the potential advantages and disadvantages of the proposed purchase to the listed corporation and its shareholders respectively.;
- (7) Any material financial effect on the listed corporation or group if the proposed purchase(s) were to be carried out in full at any time during the proposed authorised period (such as the working capital of the listed corporation as compared with the position disclosed in the most recent published or announced audited financial statements).;
- (8) A statement as to the consequences of the proposed purchase on the listed corporation and its shareholders with regard to the Take-Overs and Mergers Code or in relation to a foreign corporation, the relevant laws of the place of incorporation in respect of take-overs and mergers.;
- (9) A statement referring its shareholders to the relevant parts of its annual report where information on purchases made by the listed corporation of its own shares in the last financial year, is set out.;
- (10) The public shareholding spread of the listed corporation, as at the last practicable date.;
- (11) A statement by the board of directors whether the proposal is in the best interest of the listed corporation.;
- (12) A recommendation from the board of directors as to the voting action that shareholders should take.;
- (13) Any other information concerning the proposed purchase as shareholders and their advisers would reasonably require and would reasonably expect to find in the Share Buy-back Statement for the purposes of making an informed assessment as to the merits of approving the proposed purchase and the extent of the risks involved in doing so.

[_End of Appendix]

Appendix 12B
Contents of ordinary resolution for share buy-back

APPENDIX 12B**Contents of ordinary resolution in relation to a share buy-back**
(paragraph 12.07(1))

- (1) The total number or percentage and description of the shares which the listed corporation is authorised to purchase on the Exchange.;
- (2) The dates on which the authority conferred by the resolution will commence and determine.;
- (3) The maximum funds to be allocated by the listed corporation for the purpose of purchasing its own shares or a basis, other than reference to any person's discretion or opinion, or a formula to determine the maximum fund that is to be allocated.;
- (4) Whether the shares are proposed to be cancelled or retained as treasury shares, or both and, if available, information as to percentage or number of shares purchased which are to be retained and/or cancelled.

[_End of Appendix]

Appendix 12C
Contents of announcement for purchase,
resale or cancellation of shares

APPENDIX 12C**Part A****Contents of announcement in relation to shares purchased**
(paragraph 12.19)

- (1) The date of purchase~~;~~
- (2) The description of shares purchased~~;~~
- (3) The number of shares purchased~~;~~
- (4) The price of each share or, where relevant, the highest and lowest price paid~~;~~
- (5) The total consideration paid~~;~~
- (6) The number of shares purchased retained in treasury~~;~~
- (7) The number of shares purchased which are proposed to be cancelled~~;~~
- (8) The cumulative net outstanding treasury shares at the date of notification, where applicable~~;~~ ~~and~~
- (9) Where all or any of the shares are proposed to be cancelled, the adjusted share capital.

Part B**Contents of announcement in relation to resale of shares**
(paragraph 12.20)

- (1) The date of resale~~;~~
- (2) The description of shares resold~~;~~
- (3) The number of shares resold~~;~~
- (4) The resale price of each share or, where relevant, the highest and lowest resale price sold~~;~~
- (5) The total consideration received~~;~~ ~~and~~
- (6) The cumulative net outstanding treasury shares at the date of notification, where applicable.

Part C**Contents of announcement in relation to cancellation of shares**
(paragraph 12.21)

- (1) The number of shares cancelled~~;~~
- (2) The date of cancellation~~;~~ ~~and~~

**Appendix 12C
Contents of announcement for purchase,
resale or cancellation of shares**

- (3) The outstanding and paid-up capital of the listed corporation after cancellation.

[End of Appendix]

Appendix 12D
Disclosure in annual report for share buy-back

APPENDIX 12D**Disclosure in annual report in relation to share buy-back**
(paragraph 12.23)

- (1) A monthly breakdown of purchase(s) of its own shares made during the financial year showing the number of shares purchased each month and the purchase price per share or the highest, lowest and average price paid, and the total consideration paid for such purchase(s).
- (2) A monthly breakdown of resale(s) of its treasury shares during the financial year showing the number of treasury shares resold each month and the resale price of each share, or the highest, lowest and average resale price and the total consideration received for such resale(s).
- (3) The details of the shares retained as treasury shares during the financial year.
- (4) The details of shares cancelled during the financial year.

[-End of Appendix]

CHAPTER 13 ARRANGEMENTS AND RECONSTRUCTIONS**PART A - GENERAL****13.01 Introduction**

This Chapter sets out the requirements that must be complied by a listed corporation which intends to undertake a scheme of compromise, arrangement, amalgamation, or reconstruction.

PART B - SCHEMES OF COMPROMISE, ARRANGEMENT, AMALGAMATION AND RECONSTRUCTION**13.02 Immediate announcements**

- (1) A listed corporation which is undertaking a scheme of compromise, arrangement, amalgamation or reconstruction ("**proposed Scheme**") must immediately announce the proposed Scheme to the Exchange. The listed corporation must also immediately announce to the Exchange the information set out in Appendix 13A as and when the same becomes available.
- (2) A listed corporation must also immediately announce to the Exchange any material development in the proposed Scheme.

13.03 Contents of explanatory statement/circular

- (1) A listed corporation must ensure that any explanatory statement/circular required by Part VII of the Companies Act 1965 to be given to the holders of securities of the listed corporation includes the information set out in Appendix 13B.
- (2) The draft explanatory statement/circular must be submitted to the Exchange together with a checklist showing compliance with Appendix 13B.

PART C – SUBDIVISION OF SHARES**13.04 Application of Part C**

- (1) A listed corporation which intends to subdivide its shares must comply with all the provisions of this Part C.
- (2) The following corporations that intend to undertake a subdivision of its shares as part of its proposal or plan must comply with all requirements of this Part C except for paragraph 13.05 below:
 - (i) Cash Companies;
 - (ii) PN17 Companies; or
 - (iii) listed corporations which were similarly classified as such under the previous corresponding provisions.

[Cross reference: Practice Note 29]

-
- (3) For the purpose of this Part, unless the context otherwise requires, a “**Specified Subdivision**” is a subdivision of shares which -
- (a) is not conditional upon any other corporate proposal^{13.5}; or
 - (b) is conditional upon another corporate proposal but –
 - (i) that other corporate proposal is a subdivision or consolidation of shares; or
 - (ii) that other corporate proposal has been completed or become unconditional.

13.05 Criteria for subdivision of shares

The listed corporation must comply with the following:

- (a) the listed corporation’s share price adjusted for the subdivision of shares must not be less than RM0.50 based on the daily closing price of the listed corporation’s shares during the 3-month period before the application date;
- (b) the issued and paid-up capital of the listed corporation must be unimpaired by losses on a consolidated basis, where applicable, based on the listed corporation’s latest audited financial statements as well as its latest quarterly report;
- (c) the listed corporation is not a -
 - (i) Cash Company;
 - (ii) PN17 Company; or
 - (iii) listed corporation which was similarly classified as such under the previous corresponding provisions; and

[Cross reference: Practice Note 29]

- (d) the subdivided shares must rank pari passu in all respects with each other.

13.06 Application to subdivide shares

- (1) The listed corporation must file with the Exchange an application which include the information set out in Part A of Appendix 13C and in addition, in regard to a proposed Specified Subdivision, Part B of Appendix 13C. The application must be filed not later than 1 month from the date of the listed corporation’s announcement pertaining to the proposed subdivision.
- (2) The Exchange will exercise discretion over the approval for the subdivision of listed corporation’s shares and may approve or reject applications for the subdivision of such shares by listed corporations, as it deems fit.
- (3) Where the Exchange approves an application for the subdivision of shares by the listed corporation, such approval may be unconditional or subject to such conditions, as it deems fit.
- (4) Where the proposed subdivision is not on a Specified Subdivision, the listed corporation which has obtained approval for subdivision of shares must file with the Exchange an application for quotation of the subdivided shares, which must be accompanied by the documents specified in Part C of Appendix 13C and such other documents as may be specified in the approval-in-principle granted by the Exchange.

13.07 Procedures relating to subdivision of shares which is not a Specified Subdivision

The following procedures apply to a subdivision of shares by the listed corporation which is not a Specified Subdivision, with the necessary adaptations, as may be applicable:

- (a) listed corporation immediately announces to the Exchange upon the approval of the listed corporation's board of directors being given for the subdivision~~:-~~;
- (b) listed corporation submits application to the Exchange for the subdivision of shares~~:-~~;
- (c) listed corporation obtains ~~approval of~~ the Exchange's approval for the subdivision of shares~~:-~~;
- (d) listed corporation obtains ~~approval of~~ its shareholders' approval~~:-~~;
- (e) listed corporation immediately announces to the Exchange the books closing date and issues notices of subdivision of shares to its security holders. The trading in the shares of the listed corporation will be suspended 3 clear market days before the books closing date~~:-~~;
- (f) listed corporation issues subdivided shares~~:-~~;
- (g) listed corporation files with the Exchange an application for quotation together with supporting documents; and~~-~~;
- (h) ~~T~~he subdivided shares are listed and quoted on the Exchange 2 market days after receipt of the application for quotation together with the requisite documents and/or confirmations and the same have been found to be complete in all respects.

13.08 Procedures relating to a Specified Subdivision

The following procedures apply to a Specified Subdivision by the listed corporation, with the necessary adaptations, as may be applicable:

- (a) ~~L~~isted corporation immediately announces to the Exchange upon the approval of the listed corporation's board of directors being given for the subdivision~~:-~~;
- (b) ~~L~~isted corporation submits application to the Exchange for the Specified Subdivision~~:-~~;
- (c) ~~L~~isted corporation obtains ~~approval of~~ the Exchange's approval for the Specified Subdivision~~:-~~;
- (d) ~~L~~isted corporation obtains ~~approval of~~ its shareholder approvals~~:-~~;
- (e) ~~L~~isted corporation immediately announces to the Exchange the books closing date and the date of listing and quotation of the subdivided shares~~:-~~;
- (f) ~~L~~isted corporation issues subdivided shares~~:-~~;
- (g) ~~L~~isted corporation announces to the Exchange the books closing date on the number, type and par value of shares to be subdivided on such date; and~~-~~;
- (h) ~~T~~he subdivided shares are listed and quoted on the Exchange on the next market day following the books closing date.

13.09 Convertible securities

- (1) Where a listed corporation has previously procured approval-in-principle for the listing of shares arising from the exercise or conversion of its convertible securities ("**conversion shares**"), no further application for approval-in-principle need be made by the listed

corporation ~~under paragraph 6.04(1)~~ for listing of conversion shares that are adjusted as a result of subdivision of shares undertaken by the listed corporation.

- (2) Where a listed corporation intends to issue warrants or other convertible securities arising from adjustments due to a subdivision of shares ("**consequential securities**"), the listed corporation must comply with the provisions of Part I of Chapter 6, where applicable, in addition to those set out in this Chapter.

13.10 Announcement to the Exchange

- (1) The listed corporation must include in the announcement to the Exchange relating to the proposed subdivision the information set out in Appendix 13D.
- (2) In relation to a Specified Subdivision, a listed corporation must -
 - (a) include the date of listing and quotation of the subdivided shares in the announcement of the books closing date; and
 - (b) announce on the books closing date, the number, type and par value of the shares to be subdivided.

13.11 Circular and notices of subdivision of shares

- (1) The listed corporation must ensure that the circular to be sent to its shareholders to obtain shareholder approval for the proposed subdivision includes the information set out in Appendix 13E.
- (2) The listed corporation must ensure that the notices of subdivision of shares to be issued to its security holders includes the information set out in Appendix 13F.
- (3) The listed corporation must submit the draft circular and notice of subdivision of shares to the Exchange together with a checklist showing compliance with Appendices 13E and 13F respectively.
- (4) Subparagraph (2) above does not apply to a Specified Subdivision.

13.12 Fixing of books closing date for subdivision of shares

The listed corporation must not fix a books closing date for the purpose of subdividing its shares until -

- (a) the proposed subdivision has been approved by the Exchange; and
- (b) the approval of the shareholders in general meeting in respect of the proposed subdivision has been obtained.

13.13 Allotment of securities, despatch of notices of allotment and application for quotation in respect of subdivided shares

- (1) Within 4 market days of the books closing date for the proposed subdivision or such other period as may be prescribed by the Exchange, a listed corporation must -
 - (a) issue subdivided shares;
 - (b) despatch notices of allotment of subdivided shares to the shareholders; and
 - (c) make an application for the quotation of the subdivided shares.
- (2) Subparagraph (1) above does not apply to a Specified Subdivision.

PART D – CONSOLIDATION OF SHARES**13.14 Application of Part C**

- (1) The following provisions of Part C apply to consolidation of shares:
- (a) subparagraphs 13.04(2) and (3);
 - (b) paragraph 13.06 except that the application must include the information set out in paragraphs (1) to (5) and (7) to (10) of Part A of Appendix 13C;
 - (c) paragraph 13.05(d); and
 - (d) paragraphs 13.07, 13.08, 13.09, 13.10, 13.11, 13.12 and 13.13.
- (2) For the purposes of this paragraph, all references to subdivision of shares in relation to the provisions referred to in subparagraph (1) above mean consolidation of shares.

[End of Chapter]

Appendix 13A
Contents of announcement for the proposed Scheme

APPENDIX 13A**Contents of announcement in relation to the proposed Scheme**
(paragraph 13.02(1))

- (1) The date of the restraining order (where applicable).²³
- (2) The duration of the restraining order (where applicable).²³
- (3) A list of ~~companies~~ corporations (listed corporation and its subsidiaries) which are involved in the proposed Scheme.²³
- (4) The details of the proposed Scheme.²³
- (5) All steps proposed to be taken for the completion of the proposed Scheme.²³
- (6) The effects of the proposed Scheme, including the effect on -
 - (a) where applicable, the group structure before and after the proposed Scheme;
 - (b) the share capital;
 - (c) the substantial shareholding structure;
 - (d) the net assets per share and the earnings per share of the group; and
 - (e) the gearing position.²³
- (7) The approvals required from the relevant authorities and the conditions imposed by such authorities (if any).²³
- (8) The details of the interests of the directors, major shareholders and/or persons connected with them in the proposed Scheme.²³ ~~and~~
- (9) Where applicable, the details of the transferee corporation which must include but not be limited to the history and business of the operation.

[-_End of Appendix]

Appendix 13B
Contents of explanatory statement/circular for the proposed Scheme

APPENDIX 13B**Contents of explanatory statement/circular in relation to the proposed Scheme**
(paragraph 13.03(1))

- (1) A heading drawing attention to the importance of the document and advising holders of securities who are in any doubt as to what action to take to consult appropriate independent advisers.;
- (2) A statement that Bursa Malaysia Securities Berhad takes no responsibility for the contents of the explanatory statement/circular, makes no representation as to its accuracy or completeness and expressly disclaims any liability whatsoever for any loss howsoever arising from or in reliance upon the whole or any part of the contents of the document.;
- (3) The purpose of the document.;
- (4) The date of the restraining order (where applicable).;
- (5) The duration of the restraining order (where applicable).;
- (6) A list of the ~~companies-corporations~~ (listed corporation and its subsidiaries) which are involved in the proposed Scheme.;
- (7) The details of the proposed Scheme.;
- (8) All steps proposed to be taken for the completion of the proposed Scheme.;
- (9) The effects of the proposed Scheme, including the effect on -
 - (a) where applicable, the group structure before and after the proposed Scheme;
 - (b) the share capital;
 - (c) the substantial shareholding structure;
 - (d) the net assets per share and the earnings per share of the group; and
 - (e) the gearing position.;
- (10) The approvals required from the relevant authorities and the conditions imposed by such authorities (if any).;
- (11) The details of the interests of the directors, major shareholders and/or persons connected with them in the proposed Scheme.;
- (12) Where applicable, the details of the transferee ~~corporation~~ ~~company~~ which must include but not limited to -
 - (a) the history and business of the operation;
 - (b) the share capital;
 - (c) the information on directors, substantial shareholders and their shareholdings in the transferee;
 - (d) the details of its subsidiaries and associated companies;

Appendix 13B

Contents of explanatory statement/circular for the proposed Scheme

- (e) the details of its profit and dividend record; and
 - (f) the accountants' report on the transferee ~~company~~ corporation and the ~~companies~~ corporations to be acquired.;
- (13) A statement by the board of the directors as to whether the proposed Scheme is in the best interests of the listed corporation.;
- (14) Where voting is required, a recommendation from the board of directors as to the voting action that securities holders should take.;
- (15) An appendix containing the following information:
- (a) a responsibility statement by the directors that the explanatory statement/circular has been seen and approved by the directors of the listed corporation and that they collectively and individually accept full responsibility for the accuracy of the information given and confirm that after making all reasonable enquiries to the best of their knowledge and belief there are no other facts the omission of which would make any statement in the explanatory statement/circular misleading;
 - (b) where a person is named in the explanatory statement/circular as having advised the listed corporation or its directors, a statement that such adviser has given and has not withdrawn its written consent to the inclusion of the adviser's name and/or letter (where applicable) in the form and context in which it is included;
 - (c) a statement of all material contracts (not being contracts entered into in the ordinary course of business), entered into by the listed corporation and/or its subsidiaries and the transferee (where applicable) within 2 years immediately preceding the date of the explanatory statement/circular. The following particulars must be disclosed in respect of each such contract:
 - (i) the date of the contract;
 - (ii) the parties of the contract;
 - (iii) the general nature; and
 - (iv) the consideration and the mode of satisfaction;
 - (d) a statement of all material litigation, claims or arbitration involving the listed corporation and/or any of its subsidiaries and the transferee (where applicable) including those pending or threatened against such ~~companies~~ corporations. The following particulars must be disclosed:
 - (i) the background;
 - (ii) the date of the suit;
 - (iii) the names of the plaintiff(s) and defendant(s);
 - (iv) the estimate of the maximum exposure to liabilities;
 - (v) the directors'/solicitors' opinion of the outcome; and
 - (vi) the status;

Appendix 13B

Contents of explanatory statement/circular for the proposed Scheme

- (e) a statement that from the date of the explanatory statement/circular to the date of meeting, the following documents (or copies of the documents) in respect of the listed corporation and the transferee, where applicable, may be inspected at the registered office of the listed corporation:
- (i) the memorandum and articles of association;
 - (ii) the audited financial statements of the listed corporation/group and transferee (where applicable) for the past 2 financial years preceding the publication of the explanatory statement/circular and the latest unaudited results since the last audited financial statements;
 - (iii) all reports, letters or other documents, balance sheets, valuations and statements by any expert, any part of which is extracted or referred to in the explanatory statement/circular; and
 - (iv) the letters of consent referred to in subparagraph(b) above;
 - (v) the material contracts referred to in subparagraph (c) above; and
 - (vi) the relevant cause papers in respect of the material litigation referred to in subparagraph (d) above. ~~;~~ ~~and~~
- (16) Any other information which the securities holders and their advisers would reasonably expect to find in an explanatory statement/circular of that nature for the purpose of making an informed decision.

[End of Appendix]

Appendix 13C
Contents of application for subdivision of shares
& quotation of subdivided shares

APPENDIX 13C**Part A****Contents of an application for subdivision of shares**
(paragraph 13.06(1))

- (1) Title Page showing -
 - (a) the name of the listed issuer;
 - (b) the full title or designation of the listed issuer's existing shares and shares proposed for subdivision;
 - (c) the date of application and formal request for subdivision, specifying the amount, par value and the title of the shares after the subdivision, and whether the shares are fully paid; and
 - (d) the purpose of subdivision.;
- (2) A table showing before and after the subdivision, the following:
 - (a) the designation or title of each class of shares;
 - (b) the par value;
 - (c) the number of shares authorised by the memorandum and articles of association and number of shares issued;
 - (d) the number of unissued shares reserved for issuance for any specific purpose, and purpose for which reserved or an appropriate negative statement; and
 - (e) the ranking of the shares.;
- (3) The details of the proposed subdivision.;
- (4) The details of approvals from the other relevant authorities in relation to the proposed subdivision, if applicable.;
- (5) A confirmation from the listed issuer that the proposed subdivision of shares is allowed under its articles of association.;
- (6) A confirmation from the listed issuer that it complies with paragraph 13.05.;
- (7) The dates of meeting of directors and shareholders at which the subdivision of shares was authorised and the date of approval(s) of the relevant authorities.;
- (8) A statement as to whether there has been any important development affecting the listed issuer or its business since the latest annual report of the listed issuer. If so, a description of such development.;
- (9) The expected timeframe for completion of the proposed subdivision.;
- (10) A statement whether the subdivision is conditional upon any other corporate proposal including -
 - (a) the details of such other corporate proposals; and

Appendix 13C
Contents of application for subdivision of shares
& quotation of subdivided shares

- (b) the estimated timeframe for completion of the other corporate proposals.

Part B**Additional contents of an application for subdivision of shares which is a Specified Subdivision**

(paragraph 13.06(1))

The following documents:

- (1) **Aa**n undertaking that the subdivided shares will rank pari passu in all respects with each other.;
- (2) **Aa**n undertaking that all notices of allotment will be issued and despatched to the shareholders as expeditiously as possible and in any event, no later than 4 market days after the date of listing and quotation of the subdivided shares.;
- (3) **Aa**n undertaking that all conditions imposed by the relevant authorities, if any, which are required to be met before the listing and quotation of the subdivided shares will be met.;
- (4) **Aa**n undertaking that there are no circumstances or facts which have the effect of preventing or prohibiting the issuance, listing and/or quotation of the subdivided shares including any order, injunction or any other directive issued by any court of law; **and**;
- (5) **Aa**n undertaking to immediately inform the Exchange upon becoming aware, after submission of the application, that the listed issuer has failed to meet any of the above undertakings referred to in subparagraphs (1) to (3) above or of any circumstances or facts referred to in subparagraph (4) above.

Part C**Contents of an application for quotation of subdivided shares where the subdivision is not a Specified Subdivision**

(paragraph 13.06(4))

- (1) The number, type and par value of the existing and proposed subdivided shares.;
- (2) A confirmation that all notices of allotment have been issued and despatched to the shareholders.;
- (3) A confirmation from the listed issuer that the Depository is ready to credit the subdivided shares to the accounts of the shareholders, after receiving the allotment information for crediting of the subdivided shares.;
- (4) A confirmation that the subdivided shares will rank pari passu in all respects with each other.;
- (5) A certified true copy of the relevant resolution passed by shareholders in general meeting.;

Appendix 13C
Contents of application for subdivision of shares
& quotation of subdivided shares

- (6) A confirmation that all conditions imposed by the relevant authorities, if any, which are required to be met before the listing and quotation of the subdivided shares have been met; ~~and~~
- (7) A confirmation that ~~that~~ there are no circumstances or facts which have the effect of preventing or prohibiting the issuance, listing and/or quotation of the subdivided shares including any order, injunction or any other directive issued by any court of law.

[_End of Appendix]

Appendix 13D
Contents of announcement
for proposed subdivision of shares

APPENDIX 13D**Contents of announcement in relation to a proposed subdivision of shares**

(paragraph 13.10)

- (1) The number, type and par value of the existing and proposed subdivided shares.;
- (2) The ranking of the proposed subdivided shares.;
- (3) The reasons for and purpose of the proposed subdivision.;
- (4) The details of the proposed subdivision.;
- (5) The effect of the proposed subdivision on -
 - (a) the issued and paid-up capital and shares to be issued pursuant to existing share option schemes or shares to be issued pursuant to the exercise and/or conversion of existing convertible securities;
 - (b) the net assets per share based on the latest audited consolidated financial statements; and
 - (c) the earnings per share of the group.;
- (6) The approvals required for the proposed subdivision of shares and the estimated time frame for submission of the application to the relevant authorities.;
- (7) Whether a suspension will be imposed on the trading of the shares in view of the proposed subdivision.

[_End of Appendix]

Appendix 13E
Contents of circular for
proposed subdivision of shares

APPENDIX 13E**Contents of circular in relation to a proposed subdivision of shares**

(paragraph 13.11(1))

- (1) A heading drawing attention to the importance of the circular and advising holders of shares who are in any doubt as to what action to take to consult appropriate independent professional advisers.†
- (2) A statement that Bursa Malaysia Securities Berhad takes no responsibility for the contents of the circular, makes no representation as to its accuracy or completeness and expressly disclaims any liability whatsoever for any loss howsoever arising from or in reliance upon the whole or any part of the contents of the circular.†
- (3) The purpose of the circular.†
- (4) The reasons for and purposes of the proposed subdivision of shares.†
- (5) The details of the proposed subdivision and date on which the proposed subdivision of shares was announced.†
- (6) The number, type and par value of the existing and proposed subdivided shares.†
- (7) The listed issuer's share price adjusted for the subdivision and the basis of determining the price.†
- (8) The ranking of the proposed subdivided shares and treatment of any fractions.†
- (9) The details of any other intended corporate exercise/scheme which have been announced but not yet completed before the printing of the circular.†
- (10) The effects of the proposed subdivision on -
 - (a) the issued and paid-up capital and shares to be issued pursuant to existing share option schemes or shares to be issued pursuant to the exercise and/or conversion of existing convertible securities;
 - (b) the net assets per share based on the latest audited consolidated financial statements; and
 - (c) the earnings per share of the group.†
- (11) The expected timeframe for completion of the proposed subdivision.†
- (12) The monthly highest and lowest market prices of the listed shares transacted for the 12 months preceding the date of the circular and the last transacted price immediately before the announcement of the subdivision of shares and as at the latest practicable date before the printing of the circular.†
- (13) The approvals required for the proposed subdivision of shares and dates on which such approvals were obtained and conditions of the approvals.†
- (14) A statement by the board of directors stating whether the exercise is in the best interest of the listed issuer.†

Appendix 13E
Contents of circular for
proposed subdivision of shares

- (15) A recommendation from the board of directors as to the voting action that shareholders should take.⁵
- (16) An appendix containing the following information:
- (a) a responsibility statement by the directors that the circular has been seen and approved by the directors of the listed issuer and that they collectively and individually accept full responsibility for the accuracy of the information given and confirm that after making all reasonable enquiries to the best of their knowledge and belief there are no other facts the omission of which would make any statement in the circular misleading;
 - (b) where a person is named in the circular as having advised the listed issuer or its directors, a statement that such adviser or expert has given and has not withdrawn its written consent to the inclusion of the adviser's or expert's name and/or letter (if applicable) in the form and context in which it is included; and
 - (c) a statement that from the date of the circular until the date of the general meeting the following documents (or copies of the documents) may be inspected at the registered office of the listed issuer:
 - (i) the memorandum and articles of association;
 - (ii) the audited financial statements of the listed issuer and/or group for the past 2 financial years and the latest unaudited results since the last audited financial statements;
 - (iii) all reports, letters or other documents, balance sheets, valuations and statements by any expert, any part of which is extracted or referred to in the circular; and
 - (iv) the letters of consent referred to in subparagraph (b) above.⁵ ~~and~~
- (17) Any other information which the shareholders and their advisers would reasonably expect to find in a circular of that nature for the purpose of making an informed decision.

[_End of Appendix]

APPENDIX 13F**Notice of subdivision of shares**

(paragraph 13.11(2))

- (1) A heading drawing attention to the importance of the notice and advising holders of shares who are in any doubt as to what action to take to consult appropriate independent advisers.†
- (2) A statement that Bursa Malaysia Securities Berhad takes no responsibility for the contents of the notice, makes no representation as to its accuracy or completeness and expressly disclaims any liability whatsoever for any loss howsoever arising from or in reliance upon the whole or any part of the contents of the notice.†
- (3) The purpose of the notice.†
- (4) The details of the proposed subdivision and date on which the proposed subdivision of shares was announced.†
- (5) The approvals required for the proposed subdivision of shares and dates on which such approvals were obtained and conditions of the approvals.†
- (6) The number, type and par value of the existing and subdivided shares.†
- (7) The time and date on which the listed issuer's shares will be suspended from trading.†
- (8) The details relating to the books closing date, including last date and time for transfer, deposit and purchase of shares (where applicable).†
- (9) The details relating to the crediting of the subdivided shares.†
- (10) The details relating to allotment of the subdivided shares and the submission of application for quotation of the subdivided shares.†~~and~~
- (11) A responsibility statement by the directors that the notice has been seen and approved by the directors of the listed issuer and that they collectively and individually accept full responsibility for the accuracy of the information given and confirm that after making all reasonable enquiries to the best of their knowledge and belief there are no other facts the omission of which would make any statement in the notice misleading.

[End of Appendix]

CHAPTER 14 DEALINGS IN LISTED SECURITIES**PART A - GENERAL****14.01 Introduction**

This Chapter sets out the requirements that must be complied with by a listed issuer, its directors and principal officers in relation to dealings by its directors and principal officers in listed securities.

PART B - DEFINITIONS**14.02 Definitions**

For the purpose of this Chapter, unless the context otherwise requires -

- (a) **“1 full market day”** excludes the day on which an announcement is made. Therefore, for the purposes of paragraph 14.08(bc), regardless of what time the Exchange receives an announcement on a given day, dealings can only commence after 1 full market day from the day on which the announcement is made;
- (b) **“closed period”** means a period commencing 30 calendar days before the targeted date of announcement up to the date of the announcement of the following to the Exchange –
 - (i) in relation to a listed issuer, its quarterly results; or
 - (ii) in relation to a listed issuer which is a collective investment scheme, the fund’s quarterly results or annual reports;
- (c) **“dealing”** includes any one or more of the following actions, whether undertaken as principal or as agent -
 - (i) acquiring or disposing of securities or any interest in securities;
 - (ii) subscribing for or underwriting securities;
 - (iii) making or offering to make with any person, or inducing or attempting to induce any person to enter into or to offer to enter into -
 - (aa) any agreement for or with a view to acquiring or disposing of securities or any interest in securities;
 - (bb) any agreement for or with a view to subscribing for or underwriting securities; or
 - (cc) any agreement the purpose or avowed purpose of which is to secure a profit to any of the parties from the yield of securities or by reference to fluctuations in the values of securities; and
 - (iv) granting, accepting, acquiring, disposing of, exercising or discharging an option (whether for the call or put or both) or any other right or obligation, present or future, conditional or unconditional, to acquire or dispose of securities or any interest in securities;
- (d) **“deal”** will be construed in accordance with the meaning of “dealing” as defined above;
- (e) **“interest in securities”** has the meaning given to it under section 4 of the CMSA;

-
- (f) “**other listed issuers**” in relation to an affected person, means listed issuers other than the affected person’s own listed issuer;
- (g) “**own listed issuer**” in relation to an affected person, means the listed issuer in which an affected person holds the position of a director or a principal officer. ~~For the avoidance of doubt, this does not include the listed issuer’s associate, subsidiary or related corporation;~~
- (h) “**price-sensitive information**” means information that “on becoming generally available would or would tend to have a material effect on the price or value of securities” as referred to in section 185 of the CMSA; and
- (i) “**principal officer**” means -
- (i) in relation to a listed issuer or its major subsidiary, the chief executive who is not a director, the chief financial officer or any other employee of the listed issuer or its major subsidiary respectively who has access or is privy to price-sensitive information in relation to the listed issuer; and
 - (ii) in relation to a listed issuer which is a collective investment scheme, the chief executive of the management company who is not a director, the chief financial officer or any other employee of the management company, who has access or is privy to price-sensitive information in relation to the collective investment scheme.

PART C - APPLICATION

14.03 Application

- (1) The requirements in this Chapter apply to dealings in any listed securities by the following categories of persons (collectively referred to as “**affected persons**”):
- (a) a director of the listed issuer or its major subsidiary, or in the case of a listed issuer which is a collective investment scheme, a director of the management company; and
 - (b) a principal officer of the listed issuer or its major subsidiary, or in the case of a listed issuer which is a collective investment scheme, a principal officer of the management company, as the case may be.
- (2) Notwithstanding subparagraph (1) above, a director and principal officer of the management company of an exchange traded fund need not comply with the requirements of this Chapter.

PART D - RESTRICTIONS

14.04 Possession of price-sensitive information

An affected person must not deal in the listed securities of his own listed issuer or of other listed issuers as long as he is in possession of price-sensitive information relating to such listed securities.

14.05 General restriction on dealings

An affected person who is not in possession of price-sensitive information relating to listed securities may engage in dealings with such listed securities during a closed period provided that he complies with the procedures set out in paragraph 14.08 below.

PART E - EXEMPTIONS**14.06 Exemptions**

The following categories of dealings are exempted from the restrictions or requirements of paragraphs 14.04 and 14.05 respectively:

- (a) the acceptance or exercise of options or rights under an employee share or share option scheme;
- (b) the exercise of warrants;
- (c) the conversion of convertible securities;
- (d) the acceptance of entitlements under an issue or offer of securities, where such issue or offer is made available to all holders of a listed issuer's securities or to all holders of a relevant class of its securities, on the same terms;
- (e) the undertaking to accept, or the acceptance of a take-over offer; and
- (f) the undertaking to accept, or the acceptance of securities as part of a merger by way of a scheme of arrangement.

14.07 Subsequent dealings

For the avoidance of doubt, subsequent dealings in any securities obtained as a result of the dealings stated in paragraph 14.06 are not exempted from the restrictions in paragraphs 14.04 and 14.05.

PART F - PROCEDURES FOR DEALINGS**14.08 Procedure for dealings during closed periods**

An affected person who wishes to deal in the listed securities of his own listed issuer ("**affected company**") during a closed period must comply with the following procedures:

- (a) before the proposed dealing, the affected person must give notice of intention to deal in writing to the affected company;
- (b) upon receipt of such notice, the affected company must immediately announce to the Exchange, among others, the following information:
 - (i) the affected person's current holdings of securities in the affected company; and
 - (ii) the affected person's intention to deal in the securities of the affected company during a closed period;
- (c) the proposed dealing can only be effected after 1 full market day from the date of the announcement made pursuant to subparagraph (a) above;
- (d) the affected person must give notice of the dealing in writing to the company secretary of the affected company within 1 full market day after the dealing has occurred and the affected company must immediately announce such notice to the Exchange. The affected company must include the following in the notice and announcement:
 - (i) the date on which the dealing occurred;

-
- (ii) the consideration for the dealing; and
 - (iii) the number of securities involved in the dealing, both in absolute terms and as a percentage of all issued securities of that class in the affected company;
 - (e) a listed issuer must maintain a proper record of all notices received by it pursuant to subparagraph (d) above; and
 - (f) the company secretary of a listed issuer must, at each meeting of the board of directors, table a summary of dealings notified to the listed issuer since the last board meeting.

14.09 Procedure for dealings outside closed periods

Where an affected person deals in the listed securities of ~~his own listed issuer~~the affected company outside closed periods, the affected person, the ~~listed issuer~~affected company and the company secretary of the ~~listed issuer~~affected company must comply with the following requirements:

- (a) the affected person must, within 3 market days after the dealing has occurred, give notice of the dealing in writing to the company secretary of the affected company and the affected company must immediately announce such notice to the Exchange. The affected company must include the information set out in paragraph 14.08(d) in the notice and announcement;
- (b) the listed issuer must maintain a proper record of all notices received by it pursuant to subparagraph (a) above; and
- (c) the company secretary of the listed issuer must, at each meeting of the board of directors, table a summary of dealings notified to the listed issuer since the last board meeting.

[End of Chapter]

CHAPTER 15 CORPORATE GOVERNANCE**PART A - GENERAL****15.01 Introduction**

This Chapter sets out the requirements that must be complied with by a listed issuer and its directors with regard to corporate governance.

PART B - DIRECTORS**15.02 Composition of the board of directors**

- (1) A listed issuer must ensure that at least 2 directors or $\frac{1}{3}$ ~~rd~~ of the board of directors of a listed issuer, whichever is the higher, are independent directors.
- (2) If the number of directors of the listed issuer is not 3 or a multiple of 3, then the number nearest $\frac{1}{3}$ ~~rd~~ must be used.
- (3) In the event of any vacancy in the board of directors, resulting in non-compliance with subparagraph (1) above, a listed issuer must fill the vacancy within 3 months.

15.03 Undertaking and letter by directors

- (1) A person who is a director of a listed issuer at the time this paragraph comes into force or is appointed as a director of a listed issuer after that, must give to the Exchange immediately after this paragraph comes into force or his appointment, whichever is the later, and in any event not later than 14 days after that, an undertaking in the form as may be prescribed by the Exchange.

[Cross reference: Annexure PN21-C of Practice Note 21; Annexure ~~s~~ PN23-C & PN23-G of Practice Note 23]

- (2) A person who is appointed as an independent director must give to the Exchange immediately after this paragraph comes into force or his appointment, whichever is the later, and in any event not later than 14 days after that, a letter in the form as may be prescribed by the Exchange.

[Cross reference: Annexure PN21-D of Practice Note 21; Annexure ~~s~~ PN23-D & PN23-H of Practice Note 23]

15.04 Rights of directors

Unless otherwise provided by or subject to any applicable laws or these Requirements, a listed issuer must ensure that every director has the right to the resources, whenever necessary and reasonable for the performance of his duties, at the cost of the listed issuer and in accordance with a procedure to be determined by the board of directors, including but not limited to -

- (a) obtaining full and unrestricted access to any information pertaining to the listed issuer;
- (b) obtaining full and unrestricted access to the advice and services of the company secretary; and
- (c) obtaining independent professional or other advice.

15.05 Qualification, vacation of office and removal of directors

- (1) A listed issuer must ensure that no person is appointed or allowed to act as a director of the issuer or be involved whether directly or indirectly in the management of the issuer, including acting in an advisory capacity in relation to the issuer, if he -
- (a) has been convicted by a court of law, whether within Malaysia or elsewhere, of an offence in connection with the promotion, formation or management of a corporation;
 - (b) has been convicted by a court of law, whether within Malaysia or elsewhere, of an offence, involving fraud or dishonesty or where the conviction involved a finding that he acted fraudulently or dishonestly; or
 - (c) has been convicted by a court of law of an offence under the securities laws or the Companies Act 1965,
- within a period of 5 years from the date of conviction or if sentenced to imprisonment, from the date of release from prison, as the case may be.
- (2) For the purpose of subparagraph (1) above, “**securities laws**” means the CMSA, the Securities Industry (Central Depositories) Act 1991 and the Securities Commission Act 1993.
- (3) The office of a director will become vacant if the director -
- (a) becomes of unsound mind;
 - (b) becomes bankrupt;
 - (c) is absent from more than 50% of the total board of directors’ meetings held during a financial year; or
 - (d) is convicted by a court of law, whether within Malaysia or elsewhere, in relation to the offences set out in subparagraphs (1)(a), (b) or (c) above.
- (4) For the purposes of subparagraph (3)(c) above, if a director is appointed after the commencement of a financial year, then only the board of directors’ meetings held after his appointment will be taken into account.
- (5) Where a director is removed from office, the listed issuer must forward to the Exchange a copy of any written representations made by the director in question at the same time as copies of such representations are sent to members of the listed issuer under section 128(3)(b) of the Companies Act 1965, unless copies of such representations need not be sent out by reason of the circumstances specified in section 128(4) of the Companies Act 1965.

15.06 Restriction on directorships

- (1) A director of an applicant or a listed issuer must not hold more than 25 directorships in companies, of which -
- (a) the number of directorships in listed issuers must not be more than 10; and
 - (b) the number of directorships in companies other than listed issuers must not be more than 15.
- (2) For the purpose of this paragraph, “**companies**” means companies incorporated under or corporations registered as foreign companies under the Companies Act 1965, regardless of

whether such companies are public or private companies or whether they are listed companies or not.

[Cross reference: Practice Note 13]

15.07 Method of computation

For the purposes of paragraph 15.06 above, a director of an applicant or a listed issuer must comply with the method of calculation of number of directorships prescribed by the Exchange.

[Cross reference: Practice Note 13]

15.08 Directors' training

- (1) A director of a listed issuer must ensure that he attends such training programmes as may be prescribed by the Exchange from time to time.
- (2) The Exchange considers continuous training for directors of listed issuers as important to enable the directors to effectively discharge their duties. In this respect, the board of directors of a listed issuer must on a continuous basis, evaluate and determine the training needs of its directors. The subject matter of training must be one that aids the director in the discharge of his duties as a director. The board of directors must disclose in the annual report of the listed issuer whether its directors have attended training for the financial year. Where any of its directors have not attended any training during the financial year, the board of directors must state the reasons for the non-attendance in the annual report for each director.

[Cross reference: Practice Note 5]

PART C - AUDIT COMMITTEE

15.09 Composition of the audit committee

- (1) A listed issuer must appoint an audit committee from amongst its directors which fulfils the following requirements:
 - (a) the audit committee must be composed of ~~not~~ fewer than 3 members;
 - (b) all the audit committee members must be non-executive directors, with a majority of them being independent directors; and
 - (c) at least one member of the audit committee ~~is~~:
 - (i) must be a member of the Malaysian Institute of Accountants; or
 - (ii) if he is not a member of the Malaysian Institute of Accountants, he must have at least 3 years' working experience and -
 - (aa) he must have passed the examinations specified in Part I of the ~~1st~~ First Schedule of the Accountants Act 1967; or
 - (bb) he must be a member of one of the associations of accountants specified in Part II of the ~~1st~~ First Schedule of the Accountants Act 1967; or
 - (iii) fulfils such other requirements as prescribed or approved by the Exchange.

-
- (2) A listed issuer must ensure that no alternate director is appointed as a member of the audit committee.

[Cross reference: Practice Note 13]

15.10 Chairman of the audit committee

The members of an audit committee must elect a chairman among themselves who is an independent director.

15.11 Written terms of reference

An audit committee must have written terms of reference which deal with its authority and duties.

15.12 Functions of the audit committee

Without limiting the generality of paragraph 15.11 above, a listed issuer must ensure an audit committee ~~must~~, amongst others, discharge the following functions:

- (1) review the following and report the same to the board of directors of the listed issuer:
- (a) with the external auditor, the audit plan;
 - (b) with the external auditor, his evaluation of the system of internal controls;
 - (c) with the external auditor, his audit report;
 - (d) the assistance given by the employees of the listed issuer to the external auditor;
 - (e) the adequacy of the scope, functions, competency and resources of the internal audit functions and that it has the necessary authority to carry out its work;
 - (f) the internal audit programme, processes, the results of the internal audit programme, processes or investigation undertaken and whether or not appropriate action is taken on the recommendations of the internal audit function;
 - (g) the quarterly results and year end financial statements, before the approval by the board of directors, focusing particularly on -
 - (i) changes in or implementation of major accounting policy changes;
 - (ii) significant and unusual events; and
 - (iii) compliance with accounting standards and other legal requirements;
 - (h) any related party transaction and conflict of interests situation that may arise within the listed issuer or group including any transaction, procedure or course of conduct that raises questions of management integrity;
 - (i) any letter of resignation from the external auditors of the listed issuer; and
 - (j) whether there is reason (supported by grounds) to believe that the listed issuer's external auditor is not suitable for re-appointment; and
- (2) recommend the nomination of a person or persons as external auditors.

15.13 Attendance of other directors and employees

A listed issuer must ensure that other directors and employees attend any particular audit committee meeting only at the audit committee's invitation, specific to the relevant meeting.

15.14 Procedure of audit committee

An audit committee may regulate its own procedure, in particular -

- (a) the calling of meetings;
- (b) the notice to be given of such meetings;
- (c) the voting and proceedings of such meetings;
- (d) the keeping of minutes; and
- (e) the custody, production and inspection of such minutes.

15.15 Audit committee report

- (1) A listed issuer must ensure that its board of directors prepare an audit committee report at the end of each financial year that complies with subparagraphs (2) and (3) below.
- (2) The audit committee report must be clearly set out in the annual report of the listed issuer.
- (3) The audit committee report must include the following:
 - (a) the composition of the audit committee, including the name, designation (indicating the chairman) and directorship of the members (indicating whether the directors are independent or otherwise);
 - (b) the terms of reference of the audit committee;
 - (c) the number of audit committee meetings held during the financial year and details of attendance of each audit committee member;
 - (d) a summary of the activities of the audit committee in the discharge of its functions and duties for that financial year of the listed issuer; and
 - (e) a summary of the activities of the internal audit function or activity.

15.16 Reporting of breaches to the Exchange

Where an audit committee is of the view that a matter reported by it to the board of directors of a listed issuer has not been satisfactorily resolved resulting in a breach of these Requirements, the audit committee must promptly report such matter to the Exchange.

15.17 Rights of the audit committee

A listed issuer must ensure that wherever necessary and reasonable for the performance of its duties, an audit committee must, in accordance with a procedure to be determined by the board of directors and at the cost of the listed issuer -

- (a) have authority to investigate any matter within its terms of reference;
- (b) have the resources which are required to perform its duties;

-
- (c) have full and unrestricted access to any information pertaining to the listed issuer;
 - (d) have direct communication channels with the external auditors and person(s) carrying out the internal audit function or activity;
 - (e) be able to obtain independent professional or other advice; and
 - (f) be able to convene meetings with the external auditors, the internal auditors or both, excluding the attendance of other directors and employees of the listed issuer, whenever deemed necessary.

15.18 Quorum of an audit committee

In order to form a quorum in respect of a meeting of an audit committee, the majority of members present must be independent directors.

15.19 Retirement and resignation

In the event of any vacancy in an audit committee resulting in the non-compliance of subparagraphs 15.09(1) above, a listed issuer must fill the vacancy within 3 months.

15.20 Review of the audit committee

The board of directors of a listed issuer must review the term of office and performance of an audit committee and each of its members at least once every 3 years to determine whether such audit committee and members have carried out their duties in accordance with their terms of reference.

PART D - AUDITORS

15.21 External auditors

A listed issuer must appoint a suitable accounting firm to act as its external auditors, and amongst others, the factors to be considered for the appointment are the adequacy of the experience and resources of the firm and the persons assigned to the audit.

15.22 Removal or resignation of external auditors

Where external auditors are removed from office or give notice to the listed issuer of their desire to resign as external auditors of listed issuer, the listed issuer must forward to the Exchange a copy of any written representations or written explanations of the resignation made by the external auditors at the same time as copies of such representations or explanations are submitted to the Registrar of the Companies pursuant to section 172A of the Companies Act 1965.

15.23 Review of statements

A listed issuer must ensure that the external auditors review a statement made by the board of directors of a listed issuer pursuant to subparagraph 15.26(b) below, with regard to the state of internal control of the listed issuer and report the results thereof to the board of directors of the listed issuer.

15.24 Right to request for meeting

Upon the request of the external auditor, the chairman of the audit committee must convene a meeting of the committee to consider any matter the external auditor believes should be brought to the attention of the directors or shareholders.

PART E - CORPORATE GOVERNANCE DISCLOSURE**15.25 Disclosure pursuant to the Code**

A listed issuer must ensure that its board of directors makes the following statements in relation to its compliance with the Malaysian Code on Corporate Governance in its annual report:

- (a) a narrative statement of how the listed issuer has applied the principles set out in Part 1 of the Malaysian Code on Corporate Governance to their particular circumstances; and
- (b) a statement on the extent of compliance with the Best Practices in Corporate Governance set out in Part 2 of the Malaysian Code on Corporate Governance which statement must specifically identify and give reasons for any areas of non-compliance with Part 2 and the alternatives to the Best Practices adopted by the listed issuer, if any.

[Cross reference: Practice Note 9]

15.26 Additional statements by the board of directors

A listed issuer must ensure that its board of directors makes the following additional statements in its annual report:

- (a) a statement explaining the board of directors' responsibility for preparing the annual audited financial statements; and
- (b) a statement about the state of internal control of the listed issuer as a group.

[Cross reference: Practice Note 9]

PART F – INTERNAL AUDIT**15.27 Internal audit**

- (1) A listed issuer must establish an internal audit function which is independent of the activities it audits.
- (2) A listed issuer must ensure its internal audit function reports directly to the audit committee.

[End of Chapter]

CHAPTER 16 SUSPENSION, DE-LISTING AND ENFORCEMENT**PART A - GENERAL****16.01 Introduction**

This Chapter sets out the following:

- (a) the requirements that must be complied with by a listed issuer in respect of voluntary suspension and withdrawal by the listed issuer from the Official List; and
- (b) the powers of the Exchange with regard to -
 - (i) trading halt, suspension and de-listing of a listed issuer or any class of its listed securities by the Exchange; and
 - (ii) enforcement of these Requirements.

PART B - TRADING HALT AND SUSPENSION**16.02 Suspension of trading imposed by the Exchange**

- (1) The Exchange may at any time suspend the trading of listed securities in any of the following circumstances:
 - (a) in the event of any substantial corporate exercise or capital restructuring of a listed issuer;
 - (b) in the event of a conversion exercise of singly quoted shares to shares which are separately quoted on the Official List;
 - (c) where, in the opinion of the Exchange, it is necessary or expedient in the interest of maintaining an orderly and fair market in securities traded on the Exchange;
 - (d) in any circumstances as provided in these Requirements;
 - (e) in the event of any breach of these Requirements by a listed issuer or management company;
 - (f) upon notice by the SC to the Exchange that in its opinion a listed issuer or management company has breached or has failed to comply with any provision of the CMSA, the Securities Industry (Central Depositories) Act 1991, the Securities Commission Act 1993 or the SC's guidelines, or that it is necessary or expedient in the public interest and where it would be for the protection of investors;
 - (g) in the event of maturity of a listed debt security, -convertible security or structured warrant;
 - (h) upon the suspension of the trading of such securities listed on another stock exchange;
 - (i) upon the commencement of a voluntary winding-up of a listed issuer in accordance with the Companies Act, 1965; or
 - (j) where the Exchange deems it appropriate for some other reason.

- (2) Subject to subparagraph (3) below, where the public shareholding spread of a listed issuer is 10% or less of its total listed shares (excluding treasury shares), the Exchange shall suspend trading of the securities of the listed issuer upon expiry of 30 market days from the date of immediate announcement by the listed issuer pursuant to -
- (a) paragraph 8.02(3); or
 - (b) paragraph 9.19(48) where the listed issuer has announced that the offeror intends to maintain the listed issuer's listing status.
- In this regard, the suspension will only be uplifted upon the listed issuer's full compliance with the public shareholding spread requirements under paragraph 8.02(1) or as may be determined by the Exchange.
- (3) In a take-over offer for the acquisition of the listed shares of a listed issuer pursuant to the Take-Overs and Mergers Code or a corporate proposal undertaken by or in relation to a listed issuer, the Exchange shall suspend trading of the securities of the listed issuer upon expiry of 5 market days from the date of immediate announcement by the listed issuer that the offeror does not intend to maintain the listed issuer's listing status pursuant to paragraph 9.19(48).
- (4) The Exchange will notify the SC of any decision to suspend the trading of any class of the listed securities of a listed issuer pursuant to subparagraphs (1)(c), (e) or (h) above.

[Cross reference: Practice Notes [16](#) and [17](#)]

16.03 Voluntary suspension

The Exchange may at any time, at its discretion, suspend trading of the listed securities at the request of the listed issuer.

[Cross reference: Practice Note 2]

16.04 Trading Halt

Without prejudice to the powers of the Exchange under paragraph 16.02, the Exchange may at any time, halt the trading of any listed securities upon -

- (a) the listed issuer releasing a material announcement;
- (b) the Exchange being notified that the trading of the securities or in the case of structured warrants, the underlying securities of the structured warrant, is halted or suspended on the securities exchange where it is quoted.

[Cross reference: Practice Note 20]

PART C - WITHDRAWAL OF LISTING AND DE-LISTING BY THE EXCHANGE

16.05 Withdrawal of listing

- (1) The Exchange may grant a listed issuer's request for withdrawal from the Official List.
- (2) The Exchange will notify the SC of any decision to approve a request for withdrawal from the Official List.

16.06 Request for withdrawal

Subject to paragraph 16.07, a listed issuer may not request to withdraw its listing from the Official List, unless -

- (a) the listed issuer convenes a general meeting to obtain its shareholder approval and a separate meeting for the approval of the holders of any other class of listed securities, if applicable and the circular sent to the shareholders and the holders of any other class of listed securities includes the information set out in Part A of Appendix 16A. The draft circular must be submitted to the Exchange together with a checklist showing compliance with Part A of Appendix 16A;
- (b) the resolution for the withdrawal of its listing is approved by a majority in number representing three fourths in value of the shareholders and holders of any other class of listed securities, if applicable, present and voting either in person or by proxy at the meetings and provided that such shareholders and holders of any other class of listed securities who object to the withdrawal is not more than 10% of the value of the shareholders and holders of any other class of listed securities present and voting either in person or by proxy. Where the constituent document of the listed issuer imposes a stricter condition in respect of the votes required to approve the withdrawal of listing, such stricter condition will apply in substitution of the foregoing provision;
- (c) the shareholders and holders of any other class of listed securities, if applicable, are offered a reasonable cash alternative or other reasonable alternative (“**exit offer**”); and
- (d) the listed issuer appoints an independent adviser, which meets the approval of the independent directors, to advise and make recommendations for the consideration of the shareholders and holders of any other class of listed securities, if applicable, in connection with the withdrawal of its listing as well as the fairness and reasonableness of the exit offer.

16.07 Withdrawal in a take-over offer or corporate proposal

Notwithstanding paragraph 16.06 above, a listed issuer may withdraw its listing from the Official List in the following circumstances:

- (a) in a take-over offer, upon 90% or more of its listed shares (excluding treasury shares) being held by a shareholder either individually or jointly with associates of the said shareholder; or
- (b) in relation to a corporate proposal undertaken by or in relation to the listed issuer, upon 100% of the listed shares of the listed issuer being held by a shareholder either individually or jointly with the associates of the said shareholder,

and the listed issuer has announced the offeror’s intention not to maintain the listed issuer’s listing status pursuant to paragraph 9.19(48).

16.08 Application for withdrawal

A listed issuer intending to withdraw its listing from the Official List must file with the Exchange an application which includes the information set out in Part B of Appendix 16A.

16.09 Additional requirements

The Exchange may at its discretion impose any additional condition for the withdrawal of any listed issuer from listing on the Official List.

16.10 Withdrawal of other securities

Where a listed issuer applies to withdraw its ordinary shares from the Official List, such application will be deemed to apply to the withdrawal of other classes of securities issued by the listed issuer and listed on the Official List.

16.11 De-listing by the Exchange

- (1) The Exchange may at any time de-list a listed issuer or any listed securities from the Official List in any of the following circumstances:
- (a) where the listed issuer fails to comply with these Requirements, subject to consultation with the SC;
 - (b) in other circumstances as provided under paragraphs 8.03, 8.04, 9.28 or paragraphs 2, 3, and 4 of Practice Note 29, ~~whereupon upon which~~ the Exchange will notify the SC of the same;
[Cross reference: Practice Note 29]
 - (c) upon the de-listing of the listed issuer or the de-listing of such securities on another stock exchange;
 - (d) in relation to a SPAC, when it fails to complete a qualifying acquisition within 36 months from the date of its admission to the Exchange; or
 - (e) where in the opinion of the Exchange, circumstances exist which do not warrant the continued listing of a listed issuer or any class of its listed securities, subject to consultation with the SC where applicable.
- (2) The Exchange shall de-list a listed issuer in any one of the following circumstances:
- (a) pursuant to a directive, requirement or condition imposed by the SC, after which the Exchange will notify the SC of the decision to de-list;
 - (b) upon the maturity or expiry of a class of securities;
 - (c) upon the commencement of a voluntary winding-up of a listed issuer in accordance with the Companies Act, 1965;
 - (d) upon a winding up order being made against a listed issuer;
 - (e) where a structured warrant has been fully exercised before expiry or maturity; or
 - (f) in the case of a structured warrant, upon the de-listing of the underlying securities by the securities exchange where it is quoted.

[Cross reference: Practice Notes ~~16 and~~; Practice Note 17]

PART D - ENFORCEMENT**16.12 Breach by subsidiaries**

A breach of these Requirements by any one of the subsidiaries of a listed issuer will be deemed a breach of these Requirements by the listed issuer.

16.13 Breach by directors

A director of a listed issuer or management company, as the case may be, must not -

- (a) cause, aid or abet a breach of these Requirements by such listed issuer or management company, as the case may be; or
- (b) permit, either knowingly or where he had reasonable means of obtaining such knowledge, such listed issuer or management company, as the case may be, to commit a breach of these Requirements.

16.14 Provision of information by directors

Where a listed issuer, or management company makes an enquiry with any one of its directors for the purpose of making a disclosure pursuant to these Requirements, such director must provide information promptly to the listed issuer or management company that -

- (a) is clear, unambiguous and accurate;
- (b) does not contain any material omission; and
- (c) is not false or misleading.

16.15 Attendance before the Exchange

The directors, officers, employees or advisers of a listed issuer, management company, trustee or any other person to whom these Requirements are directed must, if so required by the Exchange, attend personally before the Board, any committee or officer(s) of the Exchange to provide any document, information and/or explanation for any purpose deemed appropriate by the Exchange and the Exchange may record statements from such persons.

16.16 Power to obtain documents

The Exchange may, for investigation purposes -

- (a) by notice in writing require an applicant, a listed issuer, management company, trustee or their directors, officers, employees or advisers, or any other person to whom these Requirements are directed, to produce for inspection any documents, books, papers, registers, records or accounts (whether recorded in documentary or electronic form) (referred to collectively as "**Information**" in this Part D) that are held by the person concerned or to which the person concerned has control or access over;
- (b) inspect and make copies of, or take notes from, such Information;
- (c) retain such Information for such periods as the Exchange deems fit; or
- (d) disclose or forward such Information to such authorities as the Exchange deems fit.

16.17 Listed issuer to ensure compliance

Where a direction is issued or an obligation is placed on an officer or other employee of an applicant, listed issuer or management company under these Requirements, such applicant, listed issuer or management company must ensure that such officer or employee complies with the said direction or obligation.

16.18 Breach of these Requirements

- (1) In the event of any breach of these Requirements by any applicant, listed issuer, management company, trustee or its directors, officers or advisers or any other person to whom these Requirements are directed, the Exchange may take or impose such actions or penalties as it considers appropriate.
- (2) The Exchange will notify the SC of any decision to take or impose any action or penalty referred to in paragraph 16.19 except where the decision is made in consultation with the SC.

16.19 Types of actions or penalties

- (1) Without prejudice to any of the powers granted to the Exchange under any written law in relation to the enforcement of these Requirements, the types of action or penalty that the Exchange may take or impose for a breach of these Requirements include any one or more of the following:
 - (a) in relation to applicants, listed issuers, management companies or trustees -
 - (i) issuance of a caution letter;
 - (ii) issuance of a private reprimand;
 - (iii) issuance of a public reprimand;
 - (iv) imposition of a fine not exceeding RM1 million;
 - (v) issuance of a letter directing the listed issuer, management company or trustee to rectify the non-compliance, which direction will remain in force until it is revoked;
 - (vi) imposition of one or more condition(s) for compliance;
 - (vii) non-acceptance of applications or submissions, with or without conditions imposed (after consultation with the SC);
 - (viii) imposition of condition(s) on the delivery or settlement of trades entered into in respect of the listed issuer's securities;
 - (ix) suspension of trading of the listed securities;
 - (x) de-listing of any listed securities;
 - (xi) de-listing of a listed issuer or any class of its listed securities;
 - (xii) mandate education or training program to be undertaken/implemented by the company-listed issuer for its directors and/or management; or
 - (xiii) any other action which the Exchange may deem appropriate.
 - (b) in relation to directors or officers of an applicant, a listed issuer, management company or trustee, a Controlling Person as defined in paragraph 2.22, or any other person to whom these Requirements are directed -
 - (i) issuance of a caution letter;
 - (ii) issuance of a private reprimand;

-
- (iii) issuance of a public reprimand;
 - (iv) imposition of a fine not exceeding RM1 million;
 - (v) issuance of a letter directing the person in default to rectify the non-compliance, which direction will remain in force until it is revoked;
 - (vi) imposition of one or more condition(s) for compliance;
 - (vii) imposition of a moratorium on or prohibition of dealings in the listed issuer's and/or other listed securities by the relevant director, officer or other person; or
 - (viii) any other action which the Exchange may deem appropriate.
- (c) in relation to advisers -
- (i) issuance of a caution letter;
 - (ii) issuance of a private reprimand;
 - (iii) issuance of a public reprimand;
 - (iv) imposition of a fine not exceeding RM1 million;
 - (v) issuance of a letter directing the adviser to rectify the non-compliance, which direction will remain in force until it is revoked;
 - (vi) imposition of one or more condition(s) for compliance;
 - (vii) non-acceptance of applications or submissions or documents, made or prepared by the adviser, with or without conditions imposed (after consultation with the SC); or
 - (viii) any other action which the Exchange may deem appropriate.
- (2) Where an applicant, a listed issuer, management company, trustee or its directors, officers or advisers or any other person to whom these Requirements are directed, has failed to comply with a direction or pay any fine imposed by the Exchange under subparagraph (1) above, the Exchange may impose additional actions or penalties as specified in subparagraph (1) on such persons. Such additional actions or penalties may include, without limitation, the imposition of additional fines in such manner as the Exchange deems fit (e.g. additional fines on a daily basis until the full amount due is paid to the Exchange) or suspension of trading or de-listing of securities in the case of a listed issuer.

16.20 Cumulative actions or penalties

The imposition of any one or more of the actions or penalties set out in paragraph 16.19 above does not preclude the Exchange from later taking or imposing such further actions or penalties, as stipulated under paragraph 16.18, against an applicant, a listed issuer, management company, trustee or its directors, officers, advisers or any other person to whom these Requirements are directed, as the Exchange thinks fit on the same facts or further facts, including de-listing, in the case of a listed issuer.

16.21 Other rights

The exercise of the powers in paragraphs 16.18 and 16.19 does not in any way prejudice the other rights of the Exchange against an applicant, a listed issuer, management company, trustee or its directors, officers or advisers or any other person to whom these Requirements are directed.

16.22 Confirmation by the Exchange

The confirmation given by the Exchange that it has no further comments on any document that is submitted to the Exchange for perusal pursuant to these Requirements will not preclude the Exchange from taking enforcement action against the listed issuer, its advisers, or both, in the event of any failure by such listed issuer, its advisers or both to comply with these Requirements pertaining to the form and content of the said document.

16.23 Notification by the Exchange

The Exchange may, at any time, and in its absolute discretion, refer the conduct of any applicant, listed issuer, management company, trustee or its directors, officers, advisers or any other person to whom these Requirements are directed, to any relevant authority or professional body, without giving notice to such persons.

16.24 Committee or sub-committee to decide

The Exchange will appoint a committee or sub-committee or officer(s) of the Exchange or Exchange Holding Company to discharge the exercise of its powers under paragraphs 16.18 and 16.19.

16.25 Rights of person

The person who is the subject of enforcement proceedings by the Exchange may request for an oral hearing before the Exchange, make submissions and procure the attendance of witnesses to answer the case made against him by the Exchange.

[_End of Chapter]

Appendix 16A
Contents of circular & application for withdrawal of listing

APPENDIX 16A**Part A****Contents of circular in relation to withdrawal of listing**

(paragraph 16.06(a))

- (1) A heading drawing attention to the importance of the circular and advising holders of securities who are in any doubt as to what action to take to consult appropriate independent professional advisers.†
- (2) A statement that Bursa Malaysia Securities Berhad takes no responsibility for the contents of the circular, makes no representation as to its accuracy or completeness and expressly disclaims any liability whatsoever for any loss howsoever arising from or in reliance upon the whole or any part of the contents of the circular.†
- (3) The reasons and facts concerning the withdrawal of securities of the listed issuer.†
- (4) The opinion of the board of directors in respect of the withdrawal.†
- (5) A letter of opinion of the independent adviser in connection with the withdrawal of the securities of the listed issuer as well as the fairness and reasonableness of the exit offer by way of an appendix.† and
- (6) An appendix containing the following information:
 - (a) a responsibility statement by the directors that the circular has been seen and approved by the directors of the listed issuer and that they collectively and individually accept full responsibility for the accuracy of the information given and confirm that after making all reasonable enquiries to the best of their knowledge and belief there are no other facts the omission of which would make any statement in the circular misleading;
 - (b) where a person is named in the circular as having advised the listed issuer or its directors, a statement that such adviser has given and has not withdrawn its written consent to the inclusion of the adviser's name and/or letter (where applicable) in the form and context in which it is included;
 - (c) a statement of all material contracts (not being contracts entered into in the ordinary course of business) entered into by the listed issuer and/or its subsidiaries within 2 years immediately preceding the date of the circular. The following particulars must be disclosed in respect of each such contract:
 - (i) the date of the contract;
 - (ii) the parties of the contract;
 - (iii) the general nature; and
 - (iv) the consideration and mode of satisfaction;
 - (d) a statement of all material litigation, claims or arbitration involving the listed issuer and/or any of its subsidiaries, including those pending or threatened against such companies/corporations. The following particulars must be disclosed:
 - (i) the background;

Appendix 16A
Contents of circular & application for withdrawal of listing

- (ii) the date of the suit;
 - (iii) the names of the plaintiff(s) and defendant(s);
 - (iv) the estimate of the maximum exposure to liabilities;
 - (v) the directors'/solicitors' opinion of the outcome; and
 - (vi) the status;
- (e) a statement that from the date of the circular to the date of the general meeting the following documents (or copies of the documents) may be inspected at the registered office of the listed issuer:
- (i) the memorandum and articles of association;
 - (ii) the audited financial statements of the listed issuer/group for the past 2 financial years and the latest unaudited results since the last audited financial statements;
 - (iii) all reports, letters or other documents, balance sheets, valuations and statements by any expert, any part of which is extracted or referred to in the circular;
 - (iv) the letters of consent referred to in subparagraph (b) above;
 - (v) the material contracts referred to in subparagraph (c) above; and
 - (vi) the relevant cause papers in respect of the material litigation referred to in subparagraph (d) above; and
- (7) Any other information which the shareholders and holders of any other class of listed securities and their advisers would reasonably expect to find in a circular of that nature for the purpose of making an informed decision.

Part B**Contents of application for withdrawal**

(paragraph 16.08)

- (1) The full and detailed reasons for the withdrawal.;
- (2) The board resolution for the withdrawal.;
- (3) The confirmation that the approval of any other relevant authority, if required, has been obtained.;
- (4) The confirmation that the listed issuer has obtained approval of its shareholders and the holders of any other class of listed securities, if applicable, in accordance with paragraph 16.06.;
- (5) Any other information or explanation as may be required by the Exchange.

[End of Appendix]

SCHEDULE OF FEES (subject to change from time to time)**1. Introduction**

1.1 Computation of listing fees

For the purposes of computing the listing fees set out under this Schedule, unless otherwise stated, the market value of the security:

- (a) In the case of initial or additional listing fees:
 - (i) will be based on the issue or offer price of the securities or where there is more than one issue or offer price, the average issue or offer price; or
 - (ii) where there is no issue or offer price:
 - (aa) shall be based on the last traded price on the first day of listing; or
 - (bb) such other valuation as may be determined by the Exchange.
 - (b) In the case of annual listing fees, subject to subparagraph (c) below:
 - (i) will be based on the last traded price on the last market day of the preceding calendar year;
 - (ii) where the securities are suspended on such market day, the last traded price before suspension; or
 - (iii) such other valuation as may be determined by the Exchange.
 - (c) In the case of the first annual listing fee payable by an applicant whose listing application has been approved, the market value of the security shall be computed in accordance with subparagraph (a) above.
 - (d) If quoted in non-Ringggit, the amount will be converted into Ringggit based on the foreign exchange rate prescribed by the Exchange in accordance with the prevailing foreign exchange rate, before applying the formula in this Schedule of Fees.
- 1.2 The Exchange reserves the right to add to, vary or delete any of the fees from the Schedule from time to time, as it deems fit.
- 1.3 Any late payment of fees will result in late payment charges calculated based on 10% per annum on daily rest basis.
- 1.4 No refund of any fees paid will be allowed
- 1.5 All payments to the Exchange must be made by cheques drawn to the order of Bursa Malaysia Securities Berhad.
- 1.6 A listed issuer must pay to the Exchange an annual listing fees set out in this Schedule annually in advance and not later than 31 January each year. All payments of initial, additional and annual listing fees to the Exchange must be accompanied with a copy of the details of the computation of the amount of listing fees payable.

2. Listing fees for shares

2.1 Initial listing fees

0.01% of the total market value of the issued capital of the listed issuer is payable for initial listing, subject to a minimum fee of RM20,000 and a maximum fee of RM200,000.

2.2 Additional listing fees

0.01% of the total market value of the additional shares listed is payable for additional listing, subject to a minimum fee of RM10,000 and a maximum fee of RM100,000.

2.3 Annual listing fees

0.0025% of the total market value of the issued capital of the listed issuer is payable as annual listing fees*, subject to a minimum fee of RM20,000 and a maximum fee of RM100,000.

* pro-rated according to the number of months the securities are listed in the year of listing.

3. Listing fees for convertible debt securities and non-convertible debt securities

3.1 Initial listing fees

0.0025% of the total market value of the securities listed is payable for initial listing, subject to a minimum fee of RM2,500 and a maximum fee of RM10,000.

3.2 Additional listing fees

No additional listing fee is payable.

3.3 Annual listing fees

A fixed fee of RM2,000* (for each class of securities) is payable as annual listing fees.

* pro-rated according to the number of ~~the number of~~ months the securities ~~is-are~~ listed in the year of maturity

4. Listing fees for sukuk or debt securities under an Exempt Regime

4.1 Initial listing fees

A fixed fee of RM3,000 (for each issuance or programme, as the case may be) is payable as initial listing fees.

4.2 Additional listing fees

No additional listing fee is payable.

4.3 Annual listing fees

A fixed fee of RM2,000 (for each issuance or programme, as the case may be) is payable as annual listing fees.

5. Listing fees for convertible equity securities

5.1 Initial listing fees

0.0025% of the total market value of the securities listed is payable for initial listing, subject to a minimum fee of RM10,000 and a maximum fee of RM200,000

5.2 Additional listing fees

No additional listing fee is payable.

5.3 Annual listing fees

0.000625% of the total market value of the securities listed is payable as annual listing fees, subject to a minimum fee of RM20,000* and a maximum fee of RM100,000* provided that -:

(a)* in the year of listing, the fees will be pro-rated according to the number of months the securities are listed subject to a minimum fee of RM20,000; and

(b) in the year of maturity, the fees will be pro-rated according to the number of months the securities ~~is~~are listed ~~in the year of maturity.~~

6 Listing fees for Structured Warrants

6.1 Initial listing fees

0.0025% of the total market value of the securities listed is payable for initial listing, subject to a minimum fee of RM10,000 and a maximum fee of RM50,000.

6.2 Additional listing fees

No additional listing fee is payable.

6.3 Annual listing fees

A fixed fee of RM500 per month of listing

7. Listing fees for trust units

7.1 Initial listing fees

A fixed fee of RM25,000 (for each class of securities) is payable as initial listing fees.

7.2 Additional listing fees

0.005% of the total market value of the additional units listed is payable for additional listing, subject to a minimum fee of RM5,000 and a maximum fee of RM25,000.

7.3 Annual listing fees

0.00125% of the total market value of the units listed is payable as annual listing fees, subject to a minimum fee of RM2,000 and a maximum fee of RM5,000.

8. Listing fees for exchange-traded funds**8.1 Initial listing fees**

A fixed fee of RM25,000 (for each fund) is payable as initial listing fees.

8.2 Additional listing fees

0.005% of the total market value of the increase in fund size is payable for additional listing, subject to a minimum fee of RM5,000 and a maximum fee of RM25,000.

For the purposes of paragraph 6.2-, "fund size" refers to the size of the fund that has been approved for listing by the Exchange.

8.3 Annual listing fees

0.00125% of the total market value of the units listed is payable as annual listing fees, subject to a minimum fee of RM2,000 and a maximum fee of RM5,000.

9. Perusal fees

For the perusal of documents, e.g. circulars, notices and reporting thereon, the Exchange will charge fees as determined from time to time.

10. Processing fees**10.1 Subdivision of shares**

For the processing of applications for subdivision of shares, a listed issuer must pay RM10,000 upon submission of the application.

10.2 Application for waiver/modification/ extension of time of the provisions of the Listing Requirements

For the processing of applications for waiver/ modification/ extension of time , a listed issuer must pay RM2,000 upon submission of the application.

10.3 New issuance of securities**11. Listing applications****(a) Bonus issues:**

RM5,000 + 0.005% of the issued and paid-up capital to be listed subject to a maximum amount of RM 300,000.

(b) Share scheme for employees:

RM3,000.

(c) All other secondary offerings of securities (rights issues, private placements etc.):

RM10,000 + 0.01% of the nominal value of the new securities issued subject to a maximum amount of RM300,000.

~~10.4 (d)~~ Structured Warrants

~~RM2,000 per structured warrants~~

~~1211~~. Valuation Review Fee

~~1211~~.1 Where a valuation report is prepared for the purpose of disclosure in circulars and documents which require prior perusal by the Exchange, a valuation review fee will be charged are as follows:

- (a) 0.01% of the total market value of the real estate subject to a minimum fees of RM3,000 and a maximum fee of RM25,000.
- (b) Where the valuation report forms part of a submission to the SC pursuant to section 212 of the CMSA and is being or has been reviewed by the SC in connection to the submission, the valuation review fee is not applicable.

~~1211~~.2 The valuation review fee must be paid to the Exchange upon submission of the valuation report to the Exchange.

**~~1312~~. Charges for advertisement of securities prescribed
(Paragraph 5.0 of Practice Note 21)**

Advertisement charges incurred or to be incurred by the Exchange pursuant to section 14(2) of the Securities Industry (Central Depositories) Act 1991 as notified by the Exchange.

BURSA MALAYSIA SECURITIES BERHAD
PRACTICE NOTE 1
DEFAULT IN PAYMENT

Details		Cross References
Effective date:	1 June 2001	Paragraphs 9.03, 9.04(l), 9.16
Revision date:	3 August 2009	

1.0 Introduction

- 1.1 This Practice Note enumerates some circumstances upon which a listed issuer must announce an event of default of interest or principal payments for loans under paragraphs 9.03 and 9.04(l) of the Listing Requirements.
- 1.2 The circumstances set out in this Practice Note are not exhaustive.
- 1.3 Nothing in this Practice Note restricts the generality of paragraphs 9.03, 9.04(l) and 9.16 of the Listing Requirements.

2.0 Events of default

- 2.1 The following are several events of default (“**Default(s)**”) the occurrence of which a listed issuer is required to immediately announce to the Exchange under paragraphs 9.03 and 9.04 of the Listing Requirements, irrespective of whether a demand has been made to the listed issuer, its subsidiaries or associated companies, as the case may be—:
- (a) default in payments of interest in respect of loan stocks or bonds, whether listed or unlisted on the Exchange;
 - (b) default in principal payments in respect of loan stocks or bonds, whether listed or unlisted on the Exchange;
 - (c) default in payments under a debenture;
 - (d) default in payments of either interest, principal sums or both in respect of a credit facility where the total amount outstanding of the defaulted credit facility is 5% or more of the net assets of the listed issuer based on the latest published or announced financial statements; or
 - (e) default in payments of either interest or principal sums or both in respect of a credit facility, which is reasonably expected to have a material effect on the price, value or market activity of any of the listed issuer’s securities or the decision of a listed issuer’s securities holder or investor in determining his choice of action. For the purpose of this subparagraph, where a listed issuer has a negative net asset, any amount in default will be considered as material.

2.2 The Defaults may be that of the listed issuer, its subsidiaries or associated companies.

3.0 Details of the announcement

3.1 A listed issuer must include the following information when announcing a Default to the Exchange:

- (a) the date of Default;
- (b) the reasons for the Default;
- (c) the measures by the listed issuer to address the Default;
- (d) the legal implications of the Default including the extent of the listed issuer's liability in respect of the obligations incurred under the agreements for the indebtedness;
- (e) the business, financial and operational impact of the Default on the listed issuer;
- (f) in the event the Default is in respect of secured loan stocks or bonds, the lines of action available to the guarantors or security holders against the listed issuer;
- (g) in the event the Default is in respect of payments under a debenture, to specify whether the Default will empower the debenture holder to appoint a receiver or receiver and manager;
- (h) whether the Default constitutes an event of default under a different agreement for indebtedness (cross default) and the details for such other default, where applicable;
- (i) where the Default is in respect of a subsidiary or associated company, a confirmation as to whether the subsidiary or associated company is a major subsidiary or major associated company, as the case may be;
- (j) where the Default is in respect of a listed issuer, major subsidiary or major associated company, as the case may be -
 - (i) a statement as to whether the listed issuer is solvent ("**Solvency Declaration**"). For this purpose, a listed issuer is regarded as "**solvent**" if the majority directors have formed the opinion that the listed issuer will be able to pay all its debts as and when they fall due within the period of 12 months from the date of the announcement; and
 - (ii) if the listed issuer is solvent, a statement that the listed issuer undertakes to provide to the Exchange, the Solvency Declaration duly executed by its board of directors within 3 market days from the announcement date; and
- (k) any other information that the Exchange may require from time to time.

3.2 After the announcement in paragraph 2.1 above, the listed issuer must announce to the Exchange -

- (a) the current status of the Default and the steps taken by the listed issuer to address the Default on a monthly basis until such time when the Default is remedied; and
- (b) immediately upon the listed issuer becoming aware of any circumstance which may render the Solvency Declaration inaccurate.

4.0 Solvency Declaration

- 4.1 In relation to paragraph 3.1(j)(ii) above, a listed issuer must ensure that its board of directors executes and submits to the Exchange, the Solvency Declaration within 3 market days from the date when the listed issuer announces a Default to the Exchange under paragraph 2.1 above.

BURSA MALAYSIA SECURITIES BERHAD
PRACTICE NOTE 2
REQUESTS FOR SUSPENSION

Details		Cross References
Effective date:	1 June 2001	Paragraph 16.03
Revision date:	3 August 2009	

1.0 Introduction

- 1.1 Suspension in the trading of securities (“**suspension**”) may be effected under any of the circumstances set out in paragraphs 16.02 and 16.03 of the Listing Requirements.
- 1.2 Suspensions may be effected at the request of the listed issuer or imposed by the Exchange independently of any such request subject to the relevant requirements set out in this Practice Note.
- 1.3 This Practice Note clarifies the operational procedures in respect of a request for suspension made by listed issuers.

2.0 Form and information for a request for suspension

- 2.1 Any request for suspension must be made in writing and in the form of Annexure PN2-A. In the addition, a listed issuer must provide to the Exchange any other information as may be requested by the Exchange.
- 2.2 The request for suspension must be signed by a member of the listed issuer’s senior management such as the company secretary, managing director or chief executive who is duly empowered to do so by the board of directors of the listed issuer.
- 2.3 The Exchange will only consider a request for suspension where the information requested pursuant to paragraph 2.1 has been fully and completely provided.

3.0 Situations which may warrant suspension

- 3.1 The Exchange may approve a listed issuer’s request for suspension where -
- (a) the listed issuer requires time to prepare and release an announcement relating to a material transaction, such as -
- (i) a very substantial transaction as defined in Chapter 10 of the Listing Requirements;
- (ii) a significant change in the business direction or policy of a listed corporation;
or

**Practice Note 2
Requests for Suspension**

-
- (iii) any other corporate exercise which the Exchange considers to be material;
 - (b) the listed issuer intends to -
 - (i) make a material announcement, including one that falls within paragraph 3.2 below (“**Very Material Announcement**”); or
 - (ii) hold a press conference to make a Very Material Announcement, before the close of trading; or
 - (c) any other reason which, in the opinion of the Exchange, justifies a suspension.
- 3.2 Without limiting the above, an announcement relating to any of the following matters will be regarded as a Very Material Announcement:
- (a) an interim financial report;
 - (b) a bonus issue or fund raising exercise;
 - (c) a transaction as defined under paragraph 10.02~~(b)~~(1) of the Listing Requirements, where the percentage ratio calculated in accordance with Chapter 10 of the Listing Requirements is 25% or more;
 - (d) a notice of take-over being served on a listed issuer which the public has no prior knowledge of; or
 - (e) any other corporate exercise.
- 3.3 A listed issuer should not request for a suspension if it relates to a corporate exercise where the facts are still in a state of flux and no disclosure can yet be made.
- 4.0 Suspension period and announcement timeframe**
- 4.1 If the Exchange grants a suspension for any of the reasons stated in paragraph 3.1, the period of suspension that may be approved by the Exchange is -
- (a) up to 3 market days only where the reason for suspension falls within the ambit of paragraph 3.1(a);
 - (b) up to 1 market day only where the reason for suspension falls within the ambit of paragraph 3.1(b); and
 - (c) such other period as deemed appropriate by the Exchange where the reason for suspension falls within the ambit of paragraph 3.1(c) .
- 4.2 For the purposes of computation of the period of suspension -
- (a) if a suspension is effected at 9.00a.m., the day the suspension is effected will be counted as 1 market day; or
 - (b) if a suspension is effected after 9.00a.m., the day suspension is effected will not be counted as 1 market day of suspension.

5.0 Announcements

- 5.1 If a suspension is granted by the Exchange under paragraph 3.1(a), the listed issuer must announce the relevant information to the Exchange on or before the expiry of the period of suspension that is approved by the Exchange pursuant to paragraph 4.1.
- 5.2 If a suspension is granted by the Exchange under paragraph 3.1(b), the listed issuer must announce the relevant information to the Exchange on the day suspension is requested to take effect.
- 5.3 If a suspension is granted by the Exchange under paragraph 3.1(c), the listed issuer must announce the relevant information to the Exchange on such date as may be specified by the Exchange.

6.0 Suspension

- 6.1 A listed issuer should submit its request for suspension at least 1 hour before the time suspension is requested to commence. For the purpose of this paragraph, the “1 hour” means any 1 hour between 9 a.m. to 1 p.m. and 2 p.m. to 5.30 p.m.
- 6.2 Where the Exchange decides to allow a suspension, such suspension will be imposed immediately upon the decision being made, even if it may be before the date or time suspension is requested to commence.
- 6.3 If the Exchange considers that the reasons given in support of a request for suspension do not warrant a suspension -
- (a) the Exchange will inform the listed issuer; and
 - (b) the Exchange may at its discretion, require a listed issuer to announce sufficient information to enable an investor to make an informed decision, as soon as practicable or within a time prescribed by the Exchange, which in any event will not be longer than 1 market day from notification.

7.0 Illustration

- 7.1 The following are illustrations of the application of paragraphs 6.1 and 6.2:
- (a) If A Bhd intends to have its securities suspended at 9.00 a.m. on Monday, it should submit its request for suspension by 4.30 p.m. on the previous Friday.
 - (b) Where the submission is made on Friday and the Exchange decides on Friday to allow the suspension, suspension will be effected immediately on Friday itself (if at that time, the trading session has not yet ended).
 - (c) However, pursuant to paragraph 4.2(b), the Exchange will not take into account the suspension effected on Friday when computing the period of suspension.

ANNEXURE PN2-A

Request for Suspension Form

(paragraph 2.1)

Name of listed issuer: _____

Date of request: _____

Period of suspension: _____ (day/s) From: _____ a.m./p.m., [_____ day & date _____] to
 _____ a.m./p.m., [_____ day & date _____]

Expected date of announcement to the Exchange: _____

Reason for request. Please tick the relevant box(es):

3.1(a): We require time to prepare and release an announcement relating to the following material transaction:

(i)	very substantial acquisition.	
(ii)	significant change in business direction or policy of a listed corporation as defined in Chapter 1 of the Listing Requirements.	
(iii)	any other corporate exercise.	

In the case of paragraph 3.1(a)(iii) above, to provide full details of the nature of the corporate exercise, including justification why the corporate exercise is material, and, if applicable the percentage ratio.

The maximum period of suspension allowed under paragraph 3.1(a)(i) – (iii) above is 3 market days.

3.1(b): We intend to make a material announcement or hold a press conference to make a material announcement before the close of trading of the following:

(i)	interim financial report	
(ii)	bonus issue or fund raising exercise	
(iii)	transaction where the percentage ratio is equal to or exceeds 25%	
(iv)	notice of take-over being served on our Company which the public has no prior knowledge	
(v)	any other corporate exercise.	

**Annexure PN2-A
Requests for Suspension Form**

In the case of paragraph 3.1(b)(v) above, to provide full details of the corporate exercise, including justification why the corporate exercise is material, and if applicable, the percentage ratio.

The maximum period of suspension allowed under paragraphs 3.1(b)(i) – (v) above is 1 market day.

If your request does not conform strictly to the requirements set out in paragraph 3.1(a) & 3.1(b) above, please provide justifications.:

3.1(c) any other reasons.

In the case of this paragraph 3.1(c), to provide full details of the nature of the corporate exercise/circumstances including why this warrants a suspension in the trading of your Company's securities; and if applicable, the percentage ratio.

We confirm that the above information is true and further that -

- (a) the announcement to the Exchange containing the request for suspension and the reasons for it, together with any additional information necessary to keep the market informed is attached;
- (b) we are not aware of any reason why the securities of our company should not be suspended; and
- (c) our past 12 months' record of suspension in tabular form is attached.

Contact Person(s):

Name: (1) _____ (2) _____

Telephone No. (Direct): (1) _____ (2) _____

(Mobile): (1) _____ (2) _____

**Annexure PN2-A
Requests for Suspension Form**

Signed by: _____

Name: _____

Designation: _____

Notes:

- (1) Please contact the relevant personnel from Listing Division for clarification/help before submitting the request for suspension.
- (2) If you are requesting for suspension to commence at 9.00 a.m. please contact the relevant personnel from Listing Division by 4.30 p.m. on the preceding trading day. If you are requesting for suspension to commence at 2.30 p.m., please contact the relevant personnel from Listing Division by 12.00 noon on the same day.
- (3) Details of the relevant contact person can be obtained from Bursa's website: www.bursamalaysia.com/website/bm/contact_us.html
- (4) Kindly fax your request to any one of the following numbers:
 - (a) 03-2072 0676
 - (b) 03-2072 0675
 - (c) 03-2072 0692
 - (d) 03-2072 0689

Past 12 Months' Record of Suspension

Date of Request	Reason for Suspension	Suspension Period Requested (Date & No of Days)	Suspension Period Allowed by the Exchange (Date & No of Days)	Extension of Suspension Requested (Date & No of Days)	Extension of Suspension Allowed by the Exchange (Date & No of Days)	Total Number of Days of Suspension	Date of Full Announcement

BURSA MALAYSIA SECURITIES BERHAD

PRACTICE NOTE 3

DISCLOSURE FOR INTERNET-RELATED BUSINESSES OR E-COMMERCE ACTIVITIES

	Details	Cross References
Effective date:	1 June 2001	Paragraphs 9.03 and 9.16
Revision date:	3 August 2009	

1.0 Introduction

- 1.1 Announcements made by listed issuers must at all times comply with the continuing disclosure requirements as set out in Chapter 9 of the Listing Requirements. Under this Chapter, listed issuers must make timely, adequate and accurate disclosure of material information to the investing public.
- 1.2 Accordingly, pursuant to paragraphs 9.03 and 9.16 of the Listing Requirements, where listed issuers announces an internet-related business or e-commerce activity including any arrangement, transaction or venture or proposed arrangement, transaction or venture in respect thereof ~~thereof~~ the same (collectively referred to as “**Venture**”), adequate and accurate disclosure of all material information must be made.
- 1.3 In this connection, this Practice Note sets out the minimum information that should be included, where applicable, in the announcements made in respect of the Ventures. The requirements provided in this Practice Note are in addition to the requirements of Chapter 10 of the Listing Requirements, where applicable.
- 1.4 Nothing in this Practice Note restricts the generality of paragraphs 9.03 and 9.16 of the Listing Requirements.

2.0 Details of the announcement

- 2.1 A listed issuer must include the following information, where applicable, in an announcement on the Ventures:
- (a) the details of the relevant business model, including -
- (i) a detailed description of the nature of the internet-related business/e-commerce activity ventured into by the listed issuer; e.g. service provider, infrastructure provider, content provider, software applications service provider or retailer;
 - (ii) the source and nature of revenue to be derived from the Venture; i.e. fees, SGcommission, advertisements, subscriptions etc.;

Practice Note 3
Disclosure for Internet-Related Businesses
or E-Commerce Activities

- (iii) the target market of the products and/or services offered, including an estimated size of the market;
 - (iv) strategic alliances or partnerships, if any, including the background, expertise and contribution of such ally or partner to the Venture; and
 - (v) the assumptions and bases in developing the business model of the Venture;
- (b) the details of the stage of development of the Venture and if already operating, details on the existing level of operations, including -
 - (i) the track record of the Venture, i.e. the number of years in operation and the revenue generated;
 - (ii) the current stage of development of the Venture, i.e. conceptual, developmental etc.;
 - (iii) the outcome of any feasibility studies undertaken with respect to the Venture and the name(s) of the consultants conducting the same, if any; and
 - (iv) the expected period of time for the Venture to become operational;
- (c) a description of the risks and rewards involved in undertaking the Venture, including -
 - (i) in the event the internet-related business or e-commerce activity is a result of an acquisition of an interest in a corporation, an explanation of the bases and assumptions used in deriving the purchase consideration and whether the valuation has been reviewed by an independent party;
 - (ii) the financial impact of the Venture, including the period within which the Venture is expected to generate revenue and profit;
 - (iii) the capital commitments and source of financing to undertake the Venture until such time when operations commence and revenue is generated;
 - (iv) the financial and business risks with respect to the Venture; and
 - (v) the business prospects of the Venture, including the key assumptions; and
- (d) the details of the technical capability and competence in the Venture, including the key personnel or technical experts or consultants vital to the Venture, including their qualifications and experience.

3.0 Disclosure of progress

- 3.1 Subsequent to the initial announcement, a listed issuer undertaking the Venture must also announce to the Exchange the status of the progress of the Venture, as follows:
- (a) simultaneously with the listed issuer's quarterly report pursuant to paragraph 9.22 of the Listing Requirements and in any event not later than 2 months after the end of each quarter of a financial year; or
 - (b) upon the occurrence of a material event or development in relation to the said Venture, whichever is the earlier.

Practice Note 3
Disclosure for Internet-Related Businesses
or E-Commerce Activities

- 3.2 The obligation imposed pursuant to paragraph 3.1 above will no longer be applicable to a listed issuer undertaking the Venture where -
- (a) the Venture is aborted; or
 - (b) the operations commence and revenue is generated.

BURSA MALAYSIA SECURITIES BERHAD

PRACTICE NOTE 5
TRAINING FOR DIRECTORS

Details		Cross References
Effective date:	15 February 2001	Paragraph 15.08
Revision date:	3 August 2009	

1.0 Introduction

- 1.1 This Practice Note prescribes the requirements of the Exchange in relation to training programmes that must be attended by directors of a listed issuer or an applicant seeking listing on the Official List of the Exchange ("**Directors**") in compliance with the Listing Requirements.
- 1.2 Pursuant to paragraph 15.08 of the Listing Requirements, Directors must attend training programmes that are prescribed by the Exchange from time to time.
- 1.3 The Exchange has prescribed that Directors attend the Mandatory Accreditation Programme ("**MAP**") under paragraph 15.08 of the Listing Requirements.

2.0 Mandatory Accreditation Programme (MAP)

- 2.1 The MAP will be organised by such body corporate as may be approved by the Exchange ("**Approved Organiser**").
- 2.2 A Director must comply with the following requirements in relation to the MAP:
- (a) A Director must attend the MAP in full and procure a certificate from the Approved Organiser to confirm his completion of the MAP;
- (b) A Director must complete the MAP within the time set out in the table below:

No.	Director	Timeframe to Complete MAP
(i)	A Director who is appointed for the first time as a director of a listed issuer	Within 4 months from the date of appointment
(ii)	A Director of an applicant seeking listing on the Exchange	Within 4 months from the date of listing of the applicant unless the Director falls within the category set out in subparagraph (i) above in which case the period in subparagraph (i) applies

- (c) Unless otherwise stipulated by the Exchange, only a Director who has been issued a certificate by the Approved Organiser for completion of the MAP within the timeframes stipulated in subparagraph (b) above or such other timeframe as may be allowed by the Exchange will be deemed to have completed the MAP.
- 2.3 The course content and duration of the MAP may be varied by the Approved Organiser with the approval of the Exchange at any time deemed necessary. A Director who has already been issued with a certificate for completing the MAP or any part of the MAP before the date of variation will not be affected by the variation.
- 3.0 Duty of listed issuers**
- 3.1 Listed issuers must notify their directors of the requirement to attend the MAP.

BURSA MALAYSIA SECURITIES BERHAD

PRACTICE NOTE 7

CLASSIFICATION OF APPLICANTS OR LISTED ISSUERS

Details		Cross References
Effective date:	1 June 2001	Paragraph 8.11 Paragraph 7.0 of Practice Note 21, Paragraph 10.0 of Practice Note 24
Revision date:	3 August 2009	

1.0 Introduction

- 1.1 The Exchange classifies all applicants seeking admission on the Official List of the Exchange as well as listed issuers into homogeneous group (“**Sectors**”) of a similar industry based on the applicants’ or listed issuers’ core business.
- 1.2 Pursuant to Bursa Malaysia Securities Berhad Main Market Listing Requirements (“**Listing Requirements**”), an applicant is required to propose its classification into any one of the Sectors (“**Classification**”) and a listed issuer is also required to make a proposal to the Exchange whenever a change to its Classification becomes necessary.
- 1.3 The Classification proposed by an applicant or a listed issuer ~~are is~~ subject to the approval of the Exchange. The Exchange reserves the right to classify an applicant or listed issuer into a sector which in the opinion of the Exchange is more appropriate for the applicant or listed issuer.
- 1.4 This Practice Note sets out the following:
- (a) the Sectors that are prescribed by the Exchange;
 - (b) the criteria in determining and proposing the Classification; and
 - (c) the manner in which an applicant or listed issuer is to inform or notify the Exchange of its proposed Classification or proposal for change in Classification, as the case may be.

2.0 Definition

- 2.1 For the purpose of this Practice Note, unless the context otherwise requires, “**core business**” means the business which provides the principal source of operating revenue or after-tax profits to an applicant or listed issuer and which comprises the principal activities of the applicant or listed issuer, and its subsidiary companies.

Practice Note 7
Classification of Applicants or Listed Issuers

3.0 Sectors prescribed by the Exchange

- 3.1 The Exchange will prescribe the Sectors for all listed issuers from time to time. The list of Sectors can be obtained from the Exchange's official website.
- 3.2 The Exchange reserves the right to vary the list of Sectors or the criteria when determining the Classification of a listed issuer and in that event, a listed issuer would be notified of its new Classification accordingly.

4.0 Classification of listed issuers

- 4.1 An applicant or a listed issuer must, when filing an application for listing to the Exchange, furnish the Exchange a proposal of its Classification by completing and submitting to the Exchange the Classification/Re-Classification Form (which is available on the Exchange's official website), together with supporting documents.
- 4.2 In determining the Classification of the applicant or listed issuer into any one of the Sectors, an applicant or a listed issuer must examine the amount of contribution made by its various business activities for the past 2 years. A listed issuer will be classified into the Sector which most closely fits its source of revenue or if there are several sources of revenue, the business which consistently generates the highest revenue of the listed issuer. The Classification will also be determined based on either the immediate end use of the product or the industry processes used.
- 4.3 Segmental reporting normally discloses revenue before tax, minority interests, extraordinary items and interest earned or incurred. Unless there is audited evidence that any of these items is specifically attributable to a class of business for which the revenue is disclosed, it will be disregarded in assessing the sources of revenue. Where any part of the listed issuer's business is to earn interest or incur interest, or interest expenses are central to its business, then such interest ~~shall~~ must be taken into account in determining the listed issuer's business.
- 4.4 The Exchange will seek to maintain stability in the Classification and will disregard what the Exchange considers to be temporary fluctuations in the fortunes of individual businesses.

5.0 Exchange's power to require additional information or instruct change in Classification

- 5.1 The Exchange may, at its discretion, require an applicant or a listed issuer to provide additional information to the Exchange.
- 5.2 The Exchange may, where the circumstances warrant the same but without assigning any reasons, classify an applicant or change the Classification of a listed issuer into a Sector which, in the opinion of the Exchange, is more appropriate for the applicant or listed issuer.

6.0 Changes to listed issuer's classification

- 6.1 Where there is a significant change in the business direction or policy in a listed issuer, the listed issuer must, upon completion of the relevant corporate exercise, immediately notify the Exchange of the proposal for change in its Classification by

Practice Note 7
Classification of Applicants or Listed Issuers

completing and submitting to the Exchange the Classification/Re-Classification Form (which is available on the Exchange's official website), together with supporting documents.

- 6.2 Where the Classification does not accurately reflect its current core business, the listed issuer must submit to the Exchange a proposal for a change by completing and submitting to the Exchange the Classification/Re-Classification Form (which is available on the Exchange's official website), together with supporting documents.
- 6.3 A listed issuer's Classification may also be reviewed by the Exchange either at its discretion, at the request of the listed issuer as per paragraphs 6.1 and 6.2 above, or of the advisers acting on its behalf.

BURSA MALAYSIA SECURITIES BERHAD
PRACTICE NOTE 9**INTERNAL CONTROL AND CORPORATE GOVERNANCE STATEMENT**

Details		Cross References
Effective date:	1 June 2001	Paragraphs 15.25 and 15.26
Revision date:	3 August 2009	

1.0 Introduction

1.1 Paragraph 15.25 of the Listing Requirements provides that a listed issuer must include the following statements ("**Corporate Governance Statement**") in its annual report in relation to its compliance with the Malaysian Code on Corporate Governance ("**Code**"):

- (a) a narrative statement of how the listed issuer has applied the principles set out in Part 1 of the Code ("**Principles**"); and
- (b) a statement on the extent of compliance with the Best Practices in Corporate Governance set out in Part 2 of the Code ("**Best Practices**") which statement must specifically identify and give reasons for any areas of non-compliance with Part 2 and the alternatives to the Best Practices adopted by the listed issuer, if any.

1.2 Paragraph 15.26(b) of the Listing Requirements requires a listed issuer to ensure that its board of directors makes a statement in its annual report about the state of internal control of the listed issuer as a group ("**Internal Control Statement**").

1.3 This Practice Note clarifies the obligation of the listed issuers in making the Corporate Governance Statement and the Internal Control Statement.

1.4 For the purpose of this Practice Note, a "**listed issuer**" does not include a collective investment scheme.

2.0 Location of the Corporate Governance Statement and the Internal Control Statement in the annual report

2.1 A listed issuer may combine both the Corporate Governance Statement and the Internal Control Statement (both statements are collectively referred to as "**said Statements**").

2.2 A listed issuer must set out the said Statements prominently and clearly in its annual report. The said Statements must not be incorporated into its Chairman's statement in the annual report as referred to in paragraph 7, Part A of Appendix 9C of the Listing Requirements.

3.0 Contents of the Corporate Governance Statement

3.1 There are 2 parts to the Corporate Governance Statement, namely -

Practice Note 9
Internal Control and Corporate Governance Statement

- (a) a narrative statement on application of the Principles; and
 - (b) a statement on extent of compliance with the Best Practices.
- 3.2 A listed issuer must ensure that the narrative statement on application of each Principle contains adequate information to enable an informed assessment of the application of each Principle by the listed issuer.
- 3.3 In making the statement on the extent of compliance with the Best Practices, a listed issuer must -
- (a) make a general statement stating whether it complies with the Best Practices. Although it need not comment separately on each Best Practice with which it complies, a listed issuer must nevertheless provide adequate information to enable an informed assessment of its corporate governance practices; and
 - (b) in respect of Best Practices which the listed issuer does not comply with, it must deal with them individually, give reasons for the non-compliance and alternatives to the Best Practices adopted, if any.
- 3.4 A listed issuer must ensure that the Corporate Governance Statement covers its corporate governance practices for the whole financial year. If a practice had been in place for only part of the financial year, the listed issuer must state so and the period during which it had been in place.
- 3.5 If a listed issuer has not complied with any Best Practice for a certain part of the financial year, but -
- (a) intends to take steps or has taken steps to be compliant with such Best Practice; or
 - (b) intends to establish or has established an alternative approach,
- such listed issuer should make a statement to that effect.
- 3.6 There are certain Best Practices that form the subject matter of provisions in the Listing Requirements. If a listed issuer does not comply with a Best Practice but complies with a Listing Requirement dealing with the same issue, it must still explain the reasons for departing from the Best Practice. Compliance with a Listing Requirement dealing with an issue also covered by a Best Practice must not be used by a listed issuer as a circumstance justifying departure from a Best Practice.

4.0 Contents of the Internal Control Statement

- 4.1 In making the Internal Control Statement a listed issuer is required to address the Principle and Best Practices in the Code which relate to internal control, namely the following:
- (a) Principle D II in Part 1 of the Code which reads as follows:

“The board should maintain a sound system of internal control to safeguard shareholders’ investment and the company’s assets.”
 - (b) Best Practice AAI in Part 2 of the Code which reads, inter alia, as follows:

“The board should explicitly assume the following specific responsibilities, which facilitate the discharge of the board’s stewardship responsibilities -

Practice Note 9
Internal Control and Corporate Governance Statement

- ◆ *Identifying principal risks and ensureing the implementation of appropriate systems to manage these risks;*
- ◆ *Reviewing the adequacy and the integrity of the company's internal control systems and management information systems, including systems for compliance with applicable laws, regulations, rules, directives and guidelines."*

4.2 In making the Internal Control Statement, a listed issuer should be guided by the **Statement on Internal Control: Guidance for Directors of Public Listed Companies** which is issued by the Taskforce on Internal Control with the support and endorsement of the Exchange.

4.3 A listed issuer must ensure that the Internal Control Statement contains adequate information to enable an informed assessment of its state of internal control.

5.0 The said Statements

5.1 The said Statements must clearly identify the board of directors of the listed issuer as the party which is making the statements.

BURSA MALAYSIA SECURITIES BERHAD
PRACTICE NOTE 11**PROVISION OF FINANCIAL ASSISTANCE**

Details		Cross References
Effective date:	1 July 2001	Paragraph 8.23
Revision date:	3 August 2009	

1.0 Introduction

1.1 Paragraph 8.23 of the Listing Requirements provides that a listed issuer or its unlisted subsidiaries may lend or advance any money or guarantee, indemnify or provide collateral for a debt ("**provision of financial assistance**") to categories of persons set out in paragraph 8.23(1)(i) to (iii). One of the categories of persons is the following:

- “(ii) persons to whom the provision of financial assistance -
- (aa) is necessary to facilitate the ordinary course of business of the listed issuer or its subsidiaries; or
 - (bb) pursuant to the ordinary course of business of the listed issuer or its subsidiaries;

such as the provision of advances to its sub-contractors or advances made to clients in the ordinary course of its moneylending business;”

1.2 This Practice Note sets out the following:

- (a) clarification of certain requirements under paragraph 8.23 of the Listing Requirements ("**Requirements**"); and
- (b) the disclosure obligations of a listed issuer in providing financial assistance pursuant to paragraph 8.23 (1)(ii) of the Listing Requirements.

1.3 This Practice Note must be read in conjunction with paragraph 8.23 of the Listing Requirements.

2.0 Clarification on Requirements

2.1 The following clarifications apply for the purpose of paragraph 8.23-(1)(ii) of the Listing Requirements:-

2.1.1 Ordinary course of business

A transaction in the "ordinary course of business" means a transaction which would reasonably be expected to be carried out by the listed issuer and its subsidiaries given the particular business the listed issuer and its subsidiaries are involved in. The

Practice Note 11
Provision of Financial Assistance

fact that the transaction is envisaged in the memorandum of association of the listed issuer and its subsidiaries is not a conclusive factor of determination.

As an example, in respect of a listed issuer involved in manufacturing activities ("**Manufacturing Company**"), the following transactions, which are by no means exhaustive, are considered to be in the ordinary course of business of the Manufacturing Company:

- (a) the purchase of materials and supplies for its manufacturing activities;
- (b) the sale of products either directly or through appointed distributors;
- (c) the purchase and/or lease of machines, equipment, vehicles and spares for its operations and office supplies;
- (d) the treatment and disposal of waste from its plants; and
- (e) the construction of plant and/or other infrastructure facilities for its operations.

2.1.2 Necessary to facilitate

In determining what constitutes "necessary to facilitate the ordinary course of business", the listed issuer must take into account whether the provision of financial assistance is essential to the listed issuer or its subsidiaries entering into, proceeding with and/or completing a transaction to the extent that if such financial assistance were not rendered, it would result in the listed issuer or its subsidiaries being unable to enter into, proceed with and/or complete such transaction.

Examples of what is necessary to facilitate the ordinary course of business, which are by no means exhaustive, are as follows:

- (a) provision of corporate guarantee or performance bond to a third party in favour of a main contractor in order for a listed issuer to secure work as a sub-contractor; and
- (b) provision of advances or collateral to or in favour of sub-contractors of the listed issuers to enable them to commence and/or complete the work for the listed issuer.

- 2.2 Subscription to or acquisition of debt securities and/or redeemable preference shares which are regulated by any written law and are subject to supervision by the SC or Bank Negara Malaysia, by a listed issuer or its unlisted subsidiaries are not considered as provision of financial assistance within paragraph 8.23 of the Listing Requirements. However, where such subscription or acquisition is a related party transaction, the listed issuer must comply with paragraph 10.08 of the Listing Requirements.

3.0 Disclosure obligations

- 3.1 A listed issuer must announce the financial assistance rendered or made by the said listed issuer or its unlisted subsidiaries pursuant to paragraph 8.23(1)(ii) of the Listing Requirements for each quarter of its financial year, if any, simultaneously with its quarterly report pursuant to paragraph 9.22 of the Listing Requirements and in any event not later than 2 months after the end of each quarter of a financial year. The listed issuer must include in its announcement the information set out in Annexure PN11-A.
- 3.2 Paragraph 3.1 above does not apply to provision of financial assistance in respect of the business of leasing, factoring, share financing, share margin financing or hire purchase

**Practice Note 11
Provision of Financial Assistance**

carried out by a listed issuer or its unlisted subsidiaries in the ordinary course of business, or such other similar business that may be determined by the Exchange.

- 3.3 Where a listed issuer and/or its subsidiary lends or advances money in the ordinary course of its business as a moneylender pursuant to paragraph 8.23(1)(ii) of the Listing Requirements, the listed issuer must include in its announcement referred to in paragraph 3.1 above the information prescribed under Appendix 8D of the Listing Requirements.

Annexure PN11-A
Contents of announcement for provision of financial assistance

ANNEXURE PN11-A

Contents of announcement in relation to provision of financial assistance
(paragraph 3.1)

- (1) The aggregate amount of financial assistance provided during the reporting quarter by type (i.e. advances, guarantees etc.) ~~and~~
- (2) The financial impact of the financial assistance provided, on the listed issuer as a group.

BURSA MALAYSIA SECURITIES BERHAD
PRACTICE NOTE 12**RECURRENT RELATED PARTY TRANSACTIONS**

Details	Cross References
Effective date: 1 July 2001	Paragraphs 10.08 and 10.09
Revision date: 3 August 2009	

1.0 Introduction

- 1.1 Paragraph 10.08 of the Listing Requirements stipulates the obligations that a listed issuer must comply with in relation to a related party transaction.
- 1.2 Paragraph 10.08 must be read together with paragraph 10.09 of the Listing Requirements which is in relation to a Recurrent Related Party Transaction.
- 1.3 This Practice Note sets out the following:
- (a) clarification of the disclosure obligations in relation to Recurrent Related Party Transactions;
 - (b) clarification of the application of paragraphs 10.08 and 10.09 to Recurrent Related Party Transactions ("**Requirements**"); and
 - (c) the information required for the circular and announcement referred to under paragraphs 10.09(2)(c) and (e).
- 1.4 This Practice Note must be read in conjunction with the Listing Requirements.
- 1.5 For the purpose of this Practice Note, a "**listed issuer**" includes the listed issuer's subsidiaries.

2.0 Application of paragraphs 10.08 and 10.09 to Recurrent Related Party Transactions

- 2.1 In addition to the obligation to immediately announce a related party transaction, paragraph 10.08(2) states that where any one of the percentage ratios of a related party transaction is 5% or more, a listed issuer must issue a circular to its shareholders, obtain specific shareholder approval of the transaction and appoint an independent adviser.
- 2.2 Further, paragraph 10.08(4) states that where any one of the percentage ratios is 25% or more, in addition to the foregoing, a listed issuer must also appoint a main adviser.
- 2.3 However, pursuant to paragraph 10.09, a listed issuer is allowed to obtain a mandate from its shareholders in respect of Recurrent Related Party Transactions ("**Mandate**").
- 2.4 Where a listed issuer has obtained a Mandate in respect of any Recurrent Related Party Transactions, the requirements of paragraph 10.08 will not apply to the Recurrent Related

Practice Note 12
Recurrent Related Party Transactions

Party Transaction which are comprised in the Mandate. This means, during the period of validity of the Mandate, the disclosure obligation as set out in paragraph 10.09(1) of the Listing Requirements, as well as the obligation to procure shareholder approval as set out under paragraph 10.08 will not apply to the Recurrent Related Party Transactions which are comprised in the Mandate.

- 2.5 However, pursuant to paragraph 10.09(2)(e) of the Listing Requirements, a listed issuer is required to immediately announce to the Exchange when the actual value of a Recurrent Related Party Transactions entered into by the listed issuer, exceeds the estimated value of the Recurrent Related Party Transaction disclosed in the circular by 10% or more.

3.0 Clarification on the Requirements

3.1 A listed issuer that wishes to obtain a Mandate must comply with all the requirements set out in paragraph 10.09 of the Listing Requirements. This paragraph sets out the clarification in relation to the following requirements stipulated under paragraph 10.09(2):

3.1.1 Recurrent Related Party Transactions

In this respect, the frequency or regularity of the transaction has to be considered. A transaction which has been made or will be made by the listed issuer at least once in 3 years in the course of its business will be considered recurrent.

3.1.2 Revenue nature necessary for day-to-day operations

In this respect, a related party transaction of a revenue nature which is necessary for day-to-day operations must either contribute directly or indirectly to the generation of revenue for the listed issuer. As an example, in the case of a plantations company, the following transactions, which are by no means exhaustive, are considered to be of a revenue nature:

- (a) the purchase and sale of seeds, fertilizers and machines in relation to its plantation business;
- (b) the appointment of sub-contractors to clear its land;
- (c) the appointment of third parties to sell its products;
- (d) the purchase of insurance policies for its properties, assets and employees;
- (e) the purchase of office supplies; and
- (f) the provision of transportation, storage and other infrastructure facilities.

3.1.3 In the ordinary course of business

A related party transaction is in the ordinary course of business, if it is a transaction which would reasonably be expected to be carried out by the listed issuer given the type of business the listed issuer is involved in. The fact that the transaction is envisaged in the memorandum of association of the listed issuer will not be a conclusive factor of determination. As an example, in respect of a listed issuer involved in manufacturing activities, the following transactions, which are by no means exhaustive, are considered to

Practice Note 12
Recurrent Related Party Transactions

be in the ordinary course of business of the listed issuer:

- (a) the purchase of raw materials and supplies for its business;
- (b) the sale of finished products either directly or through appointed distributors;
- (c) the construction of plant and/or other infrastructure facilities for its business;
- (d) the purchase and/or lease of machines, equipment, vehicles and spares for the operations of its factories;
- (e) the purchase of general insurance for its factories and employees;
- (f) the waste treatment and disposal of waste; and
- (g) the requisition of management and support services for its manufacturing business.

3.1.4 Annual renewal

The Mandate is subject to annual renewal. In this respect, any authority conferred by a Mandate will only continue to be in force until -

- (a) the conclusion of the first annual general meeting of the listed issuer following the general meeting at which such Mandate was passed, at which time it will lapse, unless by a resolution passed at the meeting, the authority is renewed;
- (b) the expiration of the period within which the next annual general meeting after that date is required to be held pursuant to section 143(1) of the Companies Act, 1965 ("**CA**") (but must not extend to such extension as may be allowed pursuant to section 143(2) of CA); or
- (c) revoked or varied by resolution passed by the shareholders in general meeting,

whichever is the earlier.

3.1.5 Annual report

In making the disclosure of the aggregate value of Recurrent Related Party Transactions conducted pursuant to the Mandate in a listed issuer's annual report, a listed issuer must provide a breakdown of the aggregate value of the Recurrent Related Party Transactions made during the financial year, amongst others, based on the following information:

- (a) the type of the Recurrent Related Party Transactions made; and
- (b) the names of the related parties involved in each type of the Recurrent Related Party Transactions made and their relationship with the listed issuer.

Practice Note 12
Recurrent Related Party Transactions

- 3.2 Notwithstanding the clarifications above, the following are not regarded as Recurrent Related Party Transactions and as such the Mandate does not apply:
- (a) the acquisition or disposal of land or land-based property except in the circumstances set out in paragraph 3.3(a) below;
 - (b) the acquisition or disposal of vessels, air crafts and plants;
 - (c) the entry into a lease of -
 - (i) a property for a period exceeding 3 years; or
 - (ii) such other assets,which involve payments of rental or such consideration on a lump sum basis (i.e. other than on an equal pro-rated monthly or annual installments);
 - (d) the provision of financial assistance pursuant to paragraph 8.23 of the Listing Requirements;
 - (e) the acquisition or disposal of securities except in the circumstances set out in paragraph 3.3(b) below;
 - (f) the entry into joint ventures;
 - (g) the grant or exercise of an option in relation to matters set out in subparagraph (a), (b), (c) and (e) above; and
 - (h) such other transactions as may be determined by the Exchange from time to time.
- 3.3 Notwithstanding paragraph 3.2 above -
- (a) a listed issuer classified under the Exchange's property sector may procure a Mandate for acquisition or disposal of land or land-based property provided that the transaction is a Recurrent Related Party Transaction and any one of the percentage ratios is not more than 10%; and
 - (b) a listed issuer under paragraph 9.20(2)(a), (b) and (c) of the Listing Requirements may procure a Mandate for acquisition or disposal of securities which is a Recurrent Related Party Transaction.
- 3.4 Notwithstanding paragraph 3.2(d) above and subject to paragraph 10.09 of the Listing Requirements and the other provisions of this Practice Note, a listed issuer may obtain a Mandate in respect of the following Recurrent Related Party Transactions:
- (a) the pooling of funds within the listed issuer's group of companies via a centralised treasury management function or such similar arrangements which entails the provision of financial assistance by the listed issuer, its unlisted subsidiaries, or both, on a short or medium term basis provided that -
 - (i) the listed issuer in seeking such a mandate in accordance with paragraphs 8.23 and 10.09 of the Listing Requirements, must include in its circular, in addition to such other information as prescribed under the Listing Requirements, the estimated amounts or value of financial assistance ("**Estimate**"); and
 - (ii) [notwithstanding paragraph 10.09\(2\)\(e\) of the Listing Requirements](#), if the actual amount of financial assistance provided or rendered exceeds the

Practice Note 12
Recurrent Related Party Transactions

Estimate, the listed issuer must immediately announce the same to the Exchange. If the percentage ratio of the amount of financial assistance provided or rendered in excess of the Estimate is 5% or more, the listed issuer must comply with paragraph 10.08 of the Listing Requirements.

For purposes of this paragraph -

- (aa) **“short or medium term basis”** means for a duration not exceeding 3 years; and
 - (bb) **“group of companies”** means the subsidiaries, associated companies of the listed issuer and the listed issuer’s immediate holding company which is listed.
- (b) provision of guarantee, indemnity or such other collateral to or in favour of another person which is necessary in order to procure a contract or secure work from the other person or to enable the other person to commence and/or complete a contract or work for the listed issuer or its subsidiaries.
- (c) provision of financial assistance in respect of the business of -
- (i) leasing, factoring or hire purchase carried out by a listed issuer or its unlisted subsidiaries; or
 - (ii) share financing or share margin financing carried out by a listed issuer or its unlisted subsidiaries which is a Participating Organisation; or
 - (iii) such other similar business that may be determined by the Exchange.

4.0 Information in circular and announcement

- 4.1 A listed issuer must include such information as set out in Annexure PN12-A and Annexure PN12-B respectively in the circular and announcement required under paragraph 10.09(2)(c) and (e) of the Listing Requirements.

ANNEXURE PN12-A

Contents of circular to shareholders for shareholder mandate
(paragraph 4.1)

- (1) A heading drawing attention to the importance of the circular and advising holders of shares who are in any doubt as to what action to take to consult appropriate independent advisers.;
- (2) A statement that Bursa Malaysia Securities Berhad takes no responsibility for the contents of the circular, makes no representation as to its accuracy or completeness and expressly disclaims any liability whatsoever for any loss howsoever arising from or in reliance upon the whole or any part of the contents of the document.;
- (3) The principal business activity of the listed issuer and its subsidiaries, the details of the nature of the Recurrent Related Party Transactions contemplated under the Mandate including the activities, products, and the estimated aggregate value of the respective Recurrent Related Party Transactions contemplated under the Mandate, and the details of the class of related parties with whom the Recurrent Related Party Transactions will be carried out including the relationship with the listed issuer and the names of these parties. Where it is not possible to determine the estimated value of the Recurrent Related Party Transaction, to state the reason.;
- (4) The rationale for, and the benefit to, the listed issuer or its subsidiary transacting with the related party.;
- (5) The listed issuer's methods or procedures to ensure that the Recurrent Related Party Transactions contemplated under the Mandate are undertaken on transaction prices and terms not more favourable to the related party than those generally available to the public and are not to the detriment of the minority shareholders.;
- (6) The audit committee's view on whether the procedures above are sufficient to ensure that Recurrent Related Party Transactions are not more favourable to the related party than those generally available to the public and are not to the detriment of the minority shareholders.;
- (7) The interest, direct or indirect, of the directors and/or major shareholders and/or persons connected with a director or major shareholder in the proposal and the related party's direct and indirect shareholdings in the listed issuer.;
- (8) A statement that the interested directors have abstained and/or will abstain from board deliberation and voting on the relevant resolution.;
- (9) A statement that the director, major shareholder and/or person connected with a director or major shareholder, which has/have any interest, direct or indirect, in the proposal will abstain from voting in respect of his/their direct and/or indirect shareholdings. Where the person connected with a director or major shareholder has any interest, direct or indirect, in the proposal, a statement that the director or major shareholder concerned will also abstain from voting in respect of his direct and/or indirect shareholdings. Further, a statement that such interested director and/or major shareholder has/have undertaken that he/they will ensure that the persons connected with him/them abstain from voting on the resolution deliberating or approving the proposal at the general meeting.;
- (10) A statement by the board of directors whether the proposal is in the best interest of the listed issuer and where a director disagrees with such statement, a statement by the director setting out the reasons and the factors taken into consideration in forming that opinion.;
- (11) The thresholds for the approval of Recurrent Related Party Transactions within the listed issuer's group of companies.;

Annexure PN12-A
Contents of circular for shareholder mandate

-
- (12) A statement that at least 2 other contemporaneous transactions with unrelated third parties for similar products/services and/or quantities will be used as comparison, wherever possible, to determine whether the price and terms offered to/by the related parties are fair and reasonable and comparable to those offered to/by other unrelated third parties for the same or substantially similar type of produces/services and/or quantities. In the event that quotation or comparative pricing from unrelated third parties cannot be obtained (for instance, if there are no unrelated third party vendors/customers of similar products or services, or if the product/service is a proprietary item), to state how the transaction price will be determined and ensure that the Recurrent Related Party Transaction is not detrimental to the listed issuer or its group of companies.ﷴ
- (13) A statement by the audit committee that the group of companies has in place adequate procedures and processes to monitor, track and identify Recurrent Related Party Transactions in a timely and orderly manner, and the frequency of review of these procedures and processes.
- (14) The actual value transacted of each Recurrent Related Party Transaction, from the date on which the existing mandate was obtained up to the latest practicable date before the printing of the draft circular (“**Actual Value**”).ﷴ
- (15) The estimated value of each Recurrent Related Party Transaction as disclosed in the preceding year’s circular to shareholders (“**Estimated Value**”).ﷴ
- (16) The reasons for the deviation, where the Actual Value exceeds the Estimated Value by 10% or more.ﷴ
- (17) A recommendation from the board of directors (other than the interested directors) as to the voting action that shareholders should take.ﷴ
- (18) An appendix containing the following information:
- (a) a responsibility statement by the directors that the circular has been seen and approved by the directors of the listed issuer and that they collectively and individually accept full responsibility for the accuracy of the information given and confirm that after making all reasonable enquiries to the best of their knowledge and belief there are no other facts the omission of which would make any statement in the circular misleading;
 - (b) where a person is named in the circular as having advised the listed issuer or its directors, a statement that such adviser has given and has not withdrawn its written consent to the inclusion of the adviser’s name and/or letter (where applicable) in the form and context in which it is included;
 - (c) a statement of all material contracts (not being contracts entered into in the ordinary course of business) entered into by the listed issuer and/or its subsidiaries within 2 years immediately preceding the date of the circular. The following particulars must be disclosed in respect of each such contract:
 - (i) the date of the contract;
 - (ii) the parties of the contract;
 - (iii) the general nature; and
 - (iv) the consideration and mode of satisfaction;

**Annexure PN12-A
Contents of circular for shareholder mandate**

-
- (d) a statement of all material litigation, claims or arbitration involving the listed issuer and/or any of its subsidiaries, including those pending or threatened against such ~~companies~~corporations. The following particulars must be disclosed:
- (i) the background;
 - (ii) the date of the suit;
 - (iii) the names of the plaintiff(s) and defendant(s);
 - (iv) the estimate of the maximum exposure to liabilities;
 - (v) the directors'/solicitors' opinion of the outcome; and
 - (vi) the status;
- (e) a statement that for a period from the date of the circular to the date of the general meeting the following documents (or copies of the said documents) may be inspected at the registered office of the listed issuer:
- (i) the memorandum and articles of association;
 - (ii) the audited financial statements of the listed issuer/group for the past 2 financial years and the latest unaudited results since the last audited financial statements;
 - (iii) all reports, letters or other documents, balance sheets, valuations and statements by any expert, any part of which is extracted or referred to in the circular;
 - (iv) the letters of consent referred to in subparagraph (b) above;
 - (v) the material contracts referred to in subparagraph (c) above; and
 - (vi) the relevant cause papers in respect of material litigation referred to in subparagraph (d) above; and
- (19) any other information concerning the proposal as shareholders and their advisers would reasonably require and would reasonably expect to find in the circular for the purposes of making an informed assessment as to the merits of approving the proposal and the extent of the risks involved in doing so.

[End of Annexure]

Annexure PN12-B
Contents of announcement for
Recurrent Related Party Transaction

ANNEXURE PN12-B

Contents of announcement for a Recurrent Related Party Transaction
(paragraph 4.1)

- (1) The estimated value of the Recurrent Related Party Transaction as disclosed in the circular to the shareholders ("**Estimated Value**").~~;~~
- (2) The actual value of the Recurrent Related Party Transaction transacted, from the date on which the existing Mandate was obtained up to the date of the announcement ("**Actual Value**").~~;~~ ~~and~~
- (3) The difference (in value and percentage) for the variation between the Actual Value and the Estimated Value by 10% or more, and the reason for the difference.

[_End of Annexure]

BURSA MALAYSIA SECURITIES BERHAD

PRACTICE NOTE 13

REQUIREMENTS FOR DIRECTORS AND SIGNATORY OF STATUTORY DECLARATION FOR ACCOUNTS

Details	Cross References
Effective date:	1 January 2003
Revision date:	3 August 2009
	Paragraphs 1.01, 9.27, 15.07, 15.09

1.0 Introduction

- 1.1 A director who is appointed to act as an “independent director” of an applicant or a listed issuer must satisfy the definition of “independent director” set out in paragraph 1.01 of the Listing Requirements (“**said definition**”). The said definition reads as follows:

*“**independent director**” means a director who is independent of management and free from any business or other relationship which could interfere with the exercise of independent judgement or the ability to act in the best interests of an applicant or a listed issuer. Without limiting the generality of the foregoing, an independent director is one who -*

- (a) *is not an executive director of the applicant, listed issuer or any related corporation of such applicant or listed issuer (each corporation is referred to as “**said Corporation**”);*
- (b) *has not been within the last 2 years and is not an officer (except as a non-executive director) of the said Corporation. For this purpose, “**officer**” has the meaning given in section 4 of the Companies Act 1965;*
- (c) *is not a major shareholder the said Corporation;*
- (d) *is not a family member of any executive director, officer or major shareholder of the said Corporation;*
- (e) *is not acting as a nominee or representative of any executive director or major shareholder of the said Corporation (this paragraph is referred to as “**paragraph (e)**”);*
- (f) *has not been engaged as an adviser by the said Corporation under such circumstances as prescribed by the Exchange or is not presently a partner, director (except as an independent director) or major shareholder, as the case may be, of a firm or corporation which provides professional advisory services to the said Corporation under such circumstances as prescribed by the Exchange (this paragraph is referred to as “**paragraph (f)**”); or*
- (g) *has not engaged in any transaction with the said Corporation under such circumstances as prescribed by the Exchange or is not presently a partner, director or major shareholder, as the case may be, of a firm or corporation (other than subsidiaries of the applicant or listed issuer) which has engaged in any transaction*

Practice Note 13
Requirements for Directors and Signatory of
Statutory Declaration for Accounts

*with the said Corporation under such circumstances as prescribed by the Exchange (this paragraph is referred to as “**paragraph (g)**”).*

- 1.2 Pursuant to paragraph 9.27 of the Listing Requirements, the director or person primarily responsible for the financial management of the listed issuer, as the case may be, who signs the statutory declaration pursuant to section 169(16) of the Companies Act 1965 (“**signatory**”) must satisfy the requirements prescribed in that [paragraph 9.27](#) (“**requisite qualifications**”).
- 1.3 Further, paragraph 15.09 of the Listing Requirements also states that at least one member of the audit committee must satisfy the requisite qualifications (“**said audit committee member**”).
- 1.4 Pursuant to paragraph 15.06 of the Listing Requirements a director of an applicant or a listed issuer may only hold not more than 10 directorships in listed issuers and not more than 15 directorships in companies other than listed issuers (“**non-listed issuers**”).
- 1.5 Paragraph 15.07 of the Listing Requirements sets out the method of computing the number of directorships that may be held by a director as stipulated under paragraph 15.06.
- 1.6 This Practice Note clarifies the following:
- (a) certain aspects of the said definition;
 - (b) the requisite qualifications in relation to the signatory and the said audit committee member; and
 - (c) the method of calculation of number of directorships held by a director of an applicant or a listed issuer.

I. INDEPENDENCE OF DIRECTORS

2.0 General

- 2.1 Directors must give effect to the spirit, intention and purpose of the said definition. If a person does not fall within any of paragraphs (a) to (g) of the said definition, it does not mean that the person will automatically qualify to be an independent director. The director concerned as well as the board of directors of the applicant or listed issuer must still apply the test of whether the said director is able to exercise independent judgment and act in the best interests of the applicant or listed issuer as set out in the said definition.
- 2.2 Paragraphs 3.0 to 5.0 of this Practice Note must be read in conjunction with the said definition.

3.0 Paragraph (e)

- 3.1 “**Nominee**” as used in paragraph (e) means a person who has been designated to act for another in his or her place. It denotes a person who is accustomed, or is under an obligation, whether formal or informal to act in accordance with the directions, instructions or wishes of another person.
- 3.2 A nominee or representative of major shareholders who fulfils all requirements of the definition of “independent director” except for the said paragraph (e), may nevertheless be considered as an “independent director” if -

Practice Note 13
Requirements for Directors and Signatory of
Statutory Declaration for Accounts

- (a) the major shareholder's aggregate shareholding in the said Corporation, directly or indirectly, is not more than 15% of the issued and paid-up capital (excluding treasury shares) of the said Corporation;
- (b) the major shareholder is not deemed to be a promoter of the said Corporation; and
- (c) the major shareholder is either -
 - (i) a statutory institution who is managing funds belonging to the general public; or
 - (ii) an entity established as a collective investment scheme, such as closed-end funds, unit trusts or investment funds (but excluding investment holding companies).

4.0 Paragraph (f)

4.1 In relation to paragraph (f), a person who is proposed to be or is an independent director ("**said Director**") is disqualified from being an independent director if he –

- (a) had personally provided professional advisory services to the said Corporation within the last 2 years; or
- (b) is presently a partner, director (except as an independent director) or major shareholder, of a firm or corporation ("**Entity**") which has provided professional advisory services to the said Corporation within the last 2 years,

and the consideration in aggregate is more than 5% of the gross revenue on a consolidated basis (where applicable) of the said Director or the Entity or RM1 million, whichever is the higher.

4.2 For the purposes of paragraph 4.1 above, the following applies:

- (a) where the Entity is a corporation, the computation of the gross revenue of the Entity must be based on its annual audited financial statements for the last 2 financial years; and
- (b) where the service is rendered by the said Director personally or by an Entity other than a corporation, the computation of the gross revenue must be based on the income tax returns of the said Director or the Entity, as the case may be, submitted to the Inland Revenue Board for the last 2 years.

5.0 Paragraph (g)

5.1 In relation to paragraph (g), the said Director is disqualified from being an independent director if he -

- (a) had engaged personally in transactions with the said Corporation (other than for board service as a non-executive director) within the last 2 years; or
- (b) is presently a partner, director, a major shareholder, of an Entity (other than subsidiaries of the applicant or listed issuer) which has engaged in transactions with the said Corporation within the last 2 years,

Practice Note 13
Requirements for Directors and Signatory of
Statutory Declaration for Accounts

and the consideration in aggregate exceeds 5% of the gross revenue on a consolidated basis (where applicable) of the said Director or the Entity or RM1 million, whichever is the higher.

- 5.2 However, “**transactions**” in paragraph 5.1 above excludes transactions -
- (a) on normal commercial terms entered into between the said Corporation and the said Director or between the said Corporation and an Entity where the said Director is also a director, major shareholder or partner -
 - (i) for personal use of the said Director; or
 - (ii) for personal investment of the said Director but not for the purpose of carrying on a trade or business;
 - (b) on normal commercial terms entered into between the said Corporation and an Entity where the said Director is also a director (and not a major shareholder) but is not involved in the said transactions;
 - (c) for the following goods and services, provided that they are sold or rendered based on a non-negotiable fixed price or rate, which is published or publicly quoted and the material terms including the prices or charges are applied consistently to all customers or classes of customers:
 - (i) provision or usage of public utility services such as water, electricity and telecommunications and data, postal or courier services, services by licensed institutions as defined under the Banking and Financial Institutions Act 1989 (other than professional advisory services which are subject to paragraph 4.1 above), insurance, unit trusts, stockbroking services, public transport, education, medical services, provision or usage of tolled highways, hotel facilities and recreational services, provision or consumption of fuel on retail or food and beverage at eateries, provision or purchase of goods at retail outlets such as supermarkets, hypermarkets or departmental stores; and
 - (ii) such other types of goods or services that may be prescribed by the Exchange from time to time.
- 5.3 For the purposes of paragraph 5.1 above, the following applies:
- (a) where the Entity is a corporation, the computation of the gross revenue of the Entity must be based on its annual audited financial statements for the last 2 financial years; **and**
 - (b) where the transaction is entered into by the said Director personally or by an Entity other than a corporation, the computation of the gross revenue must be based on the income tax returns of the said Director or the Entity, as the case may be, submitted to the Inland Revenue Board for the last 2 years.

II. REQUISITE QUALIFICATIONS FOR THE SIGNATORY AND THE SAID AUDIT COMMITTEE MEMBER

6.0 General

- 6.1 Paragraph 7.0 of this Practice Note must be read in conjunction with paragraphs 9.27 and 15.09 of the Listing Requirements.

Practice Note 13
Requirements for Directors and Signatory of
Statutory Declaration for Accounts

7.0 Requisite qualifications

- 7.1 For the purposes of paragraphs 9.27(c) and 15.09(1)(c)(iii) of the Listing Requirements, the following qualifications are also acceptable:
- (a) either one of the following qualifications and at least 3 years' post-qualification experience in accounting or finance:
 - (i) a degree/masters/doctorate in accounting or finance; or
 - (ii) a member of any professional accountancy organization which has been admitted as a full member of the International Federation of Accountants;or
 - (b) at least 7 years' experience being a chief financial officer of a corporation or having the function of being primarily responsible for the management of the financial affairs of a corporation.

III RESTRICTION IN NUMBER OF DIRECTORSHIPS

8.0 General

- 8.1 Paragraphs 9.0 and 10.0 of this Practice Note must be read in conjunction with paragraph 15.07 of the Listing Requirements.
- 8.2 Pursuant to paragraph 15.06 of the Listing Requirements a director may only hold not more than 10 directorships in listed issuers and not more than 15 directorships in non-listed issuers (collectively referred to as "**said Restriction**").

9.0 Method of computation

- 9.1 The calculation of the number of directorships that may be held by a director of a listed issuer pursuant to the said Restriction is as follows:
- (a) a directorship in a non-profit organisation is to be excluded from the computation of the number of directorships held pursuant to the said Restriction;
 - (b) a directorship in a listed issuer is to be counted as 1 directorship in a listed issuer and will not be aggregated with the directorship held in any other company;
 - (c) directorships held in the non-listed issuers are to be aggregated in the following manner:
 - (i) in relation to a listed group of companies, the following will be aggregated and counted as 1 directorship in a non-listed issuer:
 - (aa) directorships held in any of the listed issuer's subsidiaries, except where such subsidiaries are listed issuers or are also subsidiaries of the listed issuer's listed subsidiaries;
 - (bb) directorships held in the listed issuer's immediate non-listed associated companies; and

**Practice Note 13
Requirements for Directors and Signatory of
Statutory Declaration for Accounts**

- (cc) directorships held in the immediate non-listed associated companies of the companies referred to in subparagraph (c)(i)(aa) above; and
- (ii) directorships held in family-owned companies will be aggregated and counted as 1 directorship in a non-listed issuer;
- (d) for the avoidance of doubt, a directorship in a non-listed issuer that does not fall within paragraph (c) above will be counted as 1 directorship in a non-listed issuer and will not be aggregated with the directorship held in any other company.

9.2 For the purpose of paragraph 9.1 above, unless the context otherwise requires -

- (a) **“family-owned companies”** means private limited companies where the person has an interest or interests in voting shares of the company, the aggregate of the nominal amounts of which is not less than 20% of the nominal amounts of all the voting shares in the company. In this regard, **“interest in shares”** has the meaning given in section 6A of the Companies Act 1965; and
- (b) **“non-profit organisations”** means organisations whose objectives are not for profit such as charitable organisations, sports organisations, trade associations, social organisations or training organisations which are not for profit.

10.0 Illustrations

10.1 The following are illustrations of the application of paragraphs 9.1 and 9.2 above.

KEY

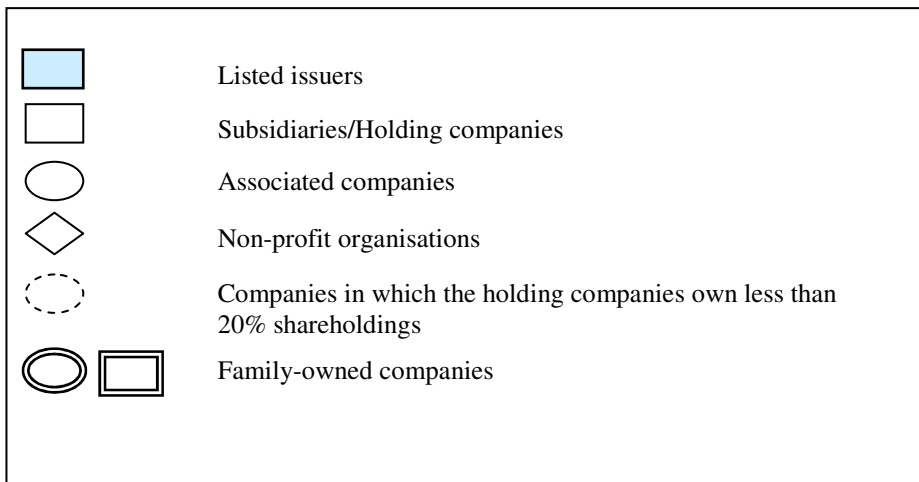
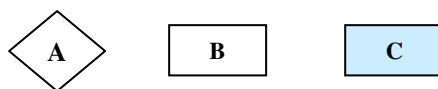

Illustration 1 (of paragraphs 9.1(a) and (b))

Facts:



Mr X is the director of A to C. Mr X has no shareholdings in A to C.

Practice Note 13
Requirements for Directors and Signatory of
Statutory Declaration for Accounts

Computation:

The number of directorships held by Mr X is 1 directorship in a listed issuer and 1 directorship in a non-listed issuer.

Basis:

- The directorship in A is excluded from the computation as A is a non-profit organisation.
- The directorship in B is counted as 1 directorship in a non-listed issuer.
- The directorship in C is counted as 1 directorship in a listed issuer.

Illustration 2 (of paragraph 9.1(c)(i))

Facts:

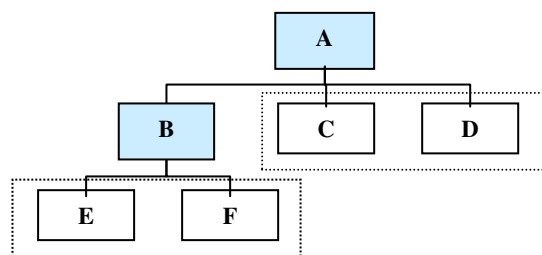

Mr X is a director of A to F. Mr X has no shareholdings in A to F.

Computation:

The number of directorships held by Mr X is 2 directorships in listed issuers and 2 directorships in non-listed issuers.

Basis:

- Directorships in A and B are counted separately as 2 directorships in listed issuers.
- Directorships in C and D are aggregated and counted as 1 directorship in a non-listed issuer because they are non-listed subsidiaries of a listed issuer i.e. A.
- Directorships in E and F are aggregated separately and counted as 1 directorship in a non-listed issuer because they are non-listed subsidiaries of a listed issuer, i.e. B.

Illustration 3 (paragraph 9.1(c)(i)(bb))

Facts:

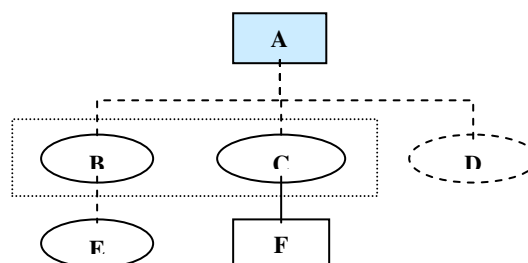

Mr X is a director of A to F. Mr X has no shareholdings in A to F.

- B – 20% owned by A
- C – 50% owned by A
- D – 15% owned by A

Practice Note 13
Requirements for Directors and Signatory of
Statutory Declaration for Accounts

E – 40% owned by B
F – 60% owned by C

Computation:

The number of directorships held by Mr X is 1 directorship in a listed issuer and 4 directorships in non-listed issuers.

Basis:

- Directorship in A is counted as 1 directorship in a listed issuer.
- Directorships in B and C are aggregated and counted as 1 directorship in non-listed issuer because they are immediate non-listed associated companies of a listed issuer, i.e. A.
- Directorship in D is counted separately as 1 directorship in a non-listed issuer because it is neither an associated company nor a subsidiary of a listed issuer, i.e. A.
- Directorships in E and F are counted separately as 2 directorships in non-listed issuers because they are not the immediate non-listed associated companies of a listed issuer, i.e. A.

Illustration 4 (of paragraph 9.1(c)(i)(cc))

Facts:

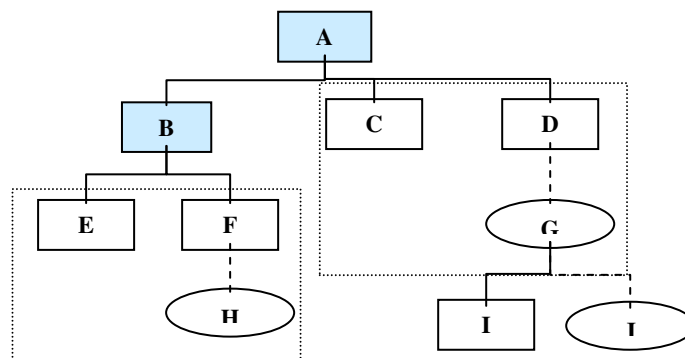

Mr X is a director of A to J. Mr X has no shareholdings in A to J.

- C – a subsidiary of A
- D – a subsidiary of A
- E – a subsidiary of B
- F – a subsidiary of B
- G – 30% owned by D
- H – 20% owned by F
- I – 60% owned by G
- J – 30% owned by G

Computation:

The number of directorships held by Mr X is 2 directorships in listed issuers and 4 directorships in non-listed issuers.

Basis:

- Directorships in A and B are counted separately as 2 directorships in listed issuers.
- Directorships in C, D and G are aggregated and counted as 1 directorship in non-listed issuer because C and D are non-listed subsidiaries of a listed issuer and G is an immediate non-listed associated company of D.

Practice Note 13
Requirements for Directors and Signatory of
Statutory Declaration for Accounts

- Directorships in E, F and H are aggregated and counted as 1 directorship in a non-listed issuer because E and F are non-listed subsidiaries of a listed issuer and H is an immediate non-listed associated company of F.
- Directorships in I and J are counted separately as 2 directorships in non-listed issuers because they are not immediate non-listed associated companies of D.

Illustration 5 (of paragraph 9.1(c)(ii))

Facts:

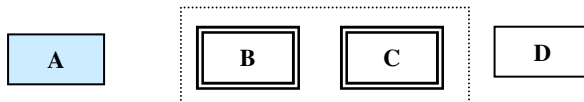

Mr X is a director of A to D. Mr X has no shareholdings in A to D unless otherwise stated below.

- B – 20% shareholdings owned by Mr X
- C – 50% shareholdings owned by Mr X
- D – 15% shareholdings owned by Mr X

Computation:

The number of directorships held by Mr X is 1 directorship in a listed issuer and 2 directorships in non-listed issuers.

Basis:

- Directorship in A is counted as 1 directorship in a listed issuer.
- Directorships in B and C are aggregated and counted as 1 directorship in a non-listed issuer because they are family-owned companies.
- Directorship in D is counted separately as 1 directorship in a non-listed issuer because it is not a family-owned company.

Illustration 6 (of paragraph 9.1(c)(ii))

Facts:

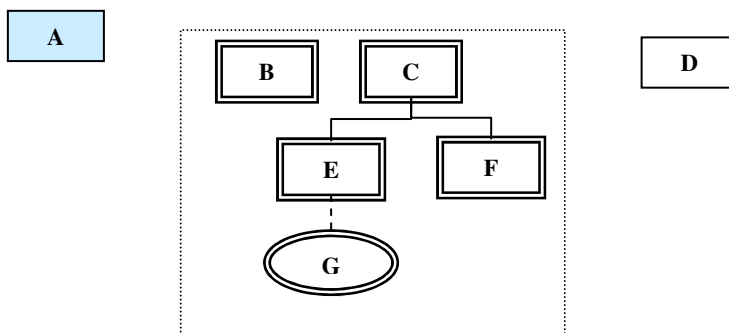

Mr X is a director of A to G. Mr X has no shareholdings in A to G unless otherwise stated below.

- B – 20% shareholdings owned by Mr X
- C – 50% shareholdings owned by Mr X and his wife
- D – 15% shareholdings owned by Mr X
- E – a subsidiary of C

Practice Note 13
Requirements for Directors and Signatory of
Statutory Declaration for Accounts

F – a subsidiary of C
 G – 40% owned by E

Computation:

The number of directorships held by Mr X is 1 directorship in a listed issuer and 2 directorships in non-listed issuers.

Basis:

- Directorship in A is counted as 1 directorship in a listed issuer.
- Directorships in B, C, E, F and G are aggregated and counted as 1 directorship in a non-listed issuer because they are family-owned companies.
- Directorship in D is counted separately as 1 directorship in a non-listed issuer because it is not a family-owned company.

Illustration 7 (of paragraphs 9.1(c)(i) and (ii))

Facts:

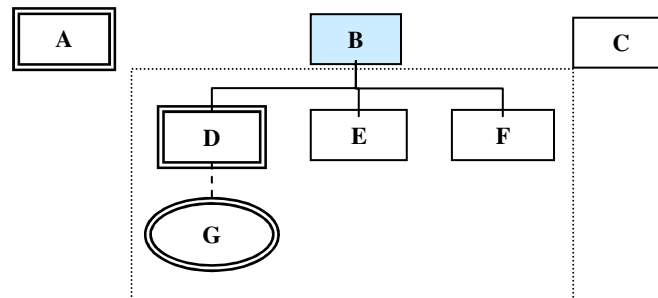

Mr X is a director of A to G. Mr X has no shareholdings in A to G unless otherwise stated below.

A - 20% shareholdings owned by Mr X
 C – 15% shareholdings owned by Mr X
 D – 21% shareholdings owned by Mr X
 E – a subsidiary of B
 F – a subsidiary of B
 G – 30% shareholdings owned by D

Computation:

The number of directorships held by Mr X is 1 directorship in a listed issuer and 3 directorships in non-listed issuers.

Basis:

- Directorship in B is counted as 1 directorship in a listed issuer.
- Directorships in E and F are aggregated and counted as 1 directorship in a non-listed issuer because they are non-listed subsidiaries of a listed issuer, i.e. B.
- Directorships in D and G may either be aggregated with the directorship in A or with the directorships in E and F, and be counted as 1 directorship in a non-listed issuer. For the purpose of this illustration, the directorships in D and G are aggregated with E and F on the basis that D is non-listed subsidiary of a listed issuer, i.e. B, and G is the immediate non-listed associated company of D.
- Directorships in A and C are counted separately as 2 directorships in non-listed issuers.

Practice Note 13
Requirements for Directors and Signatory of
Statutory Declaration for Accounts

Illustration 8

Facts:

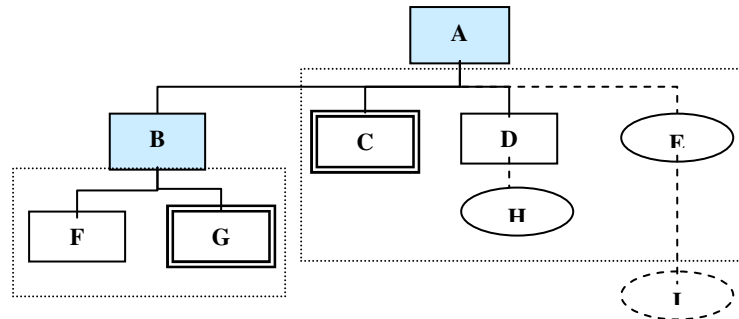

Mr X is a director of A to I. Mr X has no shareholdings in companies A to I unless otherwise stated below.

- C – 20% shareholdings owned by Mr X
- D – a subsidiary of A
- E – 20% shareholdings owned by A
- F – a subsidiary of B
- G – 20% shareholdings owned by Mr X and his wife
- H – 20% shareholdings owned by D
- I – 15% shareholdings owned by E

Computation:

The number of directorships held by Mr X is 2 directorships in listed issuers and 3 directorships in non-listed issuers.

Basis:

- Directorships in A and B are counted separately as 2 directorships in listed issuers.
- Directorships in C, D, E and H are aggregated and counted as 1 directorship in a non-listed issuer because C and D are non-listed subsidiaries of a listed issuer, i.e. A, E is an immediate non-listed associated company of A and H is an immediate non-listed associated company of D.
- Directorships in F and G are aggregated and counted as 1 directorship in a non-listed issuer because F and G are non-listed subsidiaries of a listed issuer, i.e. B.
- Directorship in I is counted separately as 1 directorship in a non-listed issuer because it is not an immediate non-listed associated company of a listed issuer or its non-listed subsidiaries.
- Although C and G are family-owned companies, they need not be aggregated separately and counted as 1 directorship in a non-listed issuer because they have already been aggregated with the other non-listed subsidiaries of A and B respectively.

Practice Note 13
Requirements for Directors and Signatory of
Statutory Declaration for Accounts

Illustration 9

Facts:

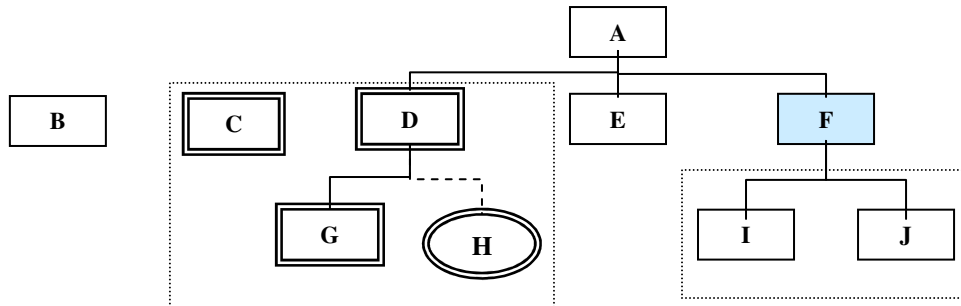

Mr X is a director of A to J. Mr X has no shareholdings in companies A to J unless otherwise stated below.

- B – 15% shareholdings owned by Mr X
- C – 70% shareholdings owned by Mr X and his wife
- D – 40% shareholdings owned by Mr X
- E – a subsidiary of A
- G – a subsidiary of D
- H – 20% shareholdings owned by D
- I – a subsidiary of F
- J – a subsidiary of F

Computation:

The number of directorships held by Mr X is 1 directorship in a listed issuer and 5 directorships in non-listed issuers.

Basis:

- Directorship in F is counted as 1 directorship in a listed issuer.
- Directorships in C, D, G and H are aggregated and counted as 1 directorship in a non-listed issuer because C, D, G and H are family-owned companies.
- Directorships in I and J are aggregated and counted as 1 directorship in a non-listed issuer because I and J are non-listed subsidiaries of a listed issuer, F.
- Directorships in A, E and B are counted separately as 3 directorships in non-listed issuers.

BURSA SECURITIES MALAYSIA BERHAD

PRACTICE NOTE 14

PRINCIPLE OF AGGREGATION FOR TRANSACTIONS

Details		Cross References
Effective date:	1 January 2003	Paragraph 10.12
Revision date:	3 August 2009	

1.0 Introduction

- 1.1 Pursuant to paragraph 10.12 of the Listing Requirements, the Exchange may aggregate separate transactions and treat such transactions as if they were one transaction in certain circumstances ("**Rule of Aggregation**").
- 1.2 This Practice Note sets out the considerations which the Exchange takes into account when applying the Rule of Aggregation.

2.0 Principles of aggregation

- 2.1 The Exchange generally considers the following principles in applying the Rule of Aggregation:
- (a) **A** transaction will be aggregated with an earlier transaction for the purpose of determining the obligations applicable in respect of the latest transaction except in the following circumstances:
- (i) a transaction that has been announced earlier pursuant to Chapter 10 of the Listing Requirements, will not be aggregated with the latest transaction when determining whether an announcement is required; and
 - (ii) a transaction which has been approved by shareholders or which was the subject of aggregation with a transaction which has been approved by shareholders pursuant to Chapter 10 of the Listing Requirements, will not be aggregated with the latest transaction when determining whether any obligations are applicable; and
- (b) **I**f the aggregation of transactions results in a requirement for shareholder approval under Chapter 10 of the Listing Requirements, then that approval is required only for the latest transaction. The earlier transaction(s) would only require disclosure in the circular which must include the information prescribed under the Listing Requirements.

Practice Note 14
Principle of Aggregation for Transactions

Illustration 1:**Facts:**

Listed issuer, Z Bhd started to conduct business with a non-related party, Mr B in 2002. The transactions entered into between Z Bhd and Mr B during the year are as follows:

Transactions	Date of Transactions	Relevant Percentage Ratio
Transaction 1	January 2002	1%
Transaction 2	February 2002	4%
Transaction 3	Early March 2002	1%
Transaction 4	End March 2002	5%
Transaction 5	April 2002	6%
Transaction 6	November 2002	10%

Based on the above facts, the application of the principles set out in sub-paragraphs (a) and (b) above is as follows:

- (i) Transaction 2 will be aggregated with Transaction 1 to determine the obligations that are applicable. As the aggregate percentage ratio of Transactions 1 and 2 is 5%, Transaction 2 must be announced pursuant to paragraph 10.06 of the Listing Requirements. The announcement must include information on Transaction 1 which must include the information set out in Appendix 10A of the Listing Requirements;
- (ii) Transactions 1 and 2 will be aggregated with Transaction 3 to determine the obligations that are applicable. However for purposes of determining whether an announcement is required, Transactions 1 and 2 will be excluded from aggregation with Transaction 3 as they have already been announced. As the percentage ratio of Transaction 3 is only 1%, no announcement is required. As the aggregate percentage ratio for Transactions 1 to 3 is 6%, no other obligation is triggered;
- (iii) Transaction 4 will be aggregated with Transactions 1 to 3 to determine the obligations that are applicable. However for purposes of determining whether an announcement is required, Transactions 1 and 2 will be excluded from aggregation with Transaction 4 as they have already been announced. As the aggregate percentage ratio for Transactions 3 and 4 is 6%, an announcement is required. The announcement must include information on Transaction 3 which must include the information set out in Appendix 10A of the Listing Requirements. As the aggregate percentage ratio of Transactions 1 to 4 is 11%, no other obligation is triggered;
- (iv) Transaction 5 will be aggregated with Transactions 1 to 4 to determine the obligations that are applicable. However, for purposes of determining whether an announcement is required, Transactions 1 to 4 will be excluded from aggregation with Transaction 5 as they have all been announced. As the percentage ratio for Transaction 5 is 6%, Transaction 5 on its own requires an announcement—; and

Practice Note 14
Principle of Aggregation for Transactions

- (v) Transaction 6 will be aggregated with Transactions 1 to 5 to determine the obligations that are applicable. However for purposes of determining whether an announcement is required, Transactions 1 to 5 will be excluded from aggregation with Transaction 6 as they have all been announced. As the percentage ratio for Transaction 6 is 10%, Transaction 6 on its own requires an announcement. As the aggregate percentage ratio for Transactions 1 to 6 is 27%, shareholder approval is required in respect of the latest transaction, i.e. Transaction 6. In this respect, information on Transactions 1, 2, 3, 4 and 5 must be included in the circular issued which must include the information set out in Appendix 10B of the Listing Requirements.

Illustration 2:**Facts:**

In addition to the facts set out in Illustration 1, Z Bhd entered into Transaction 7 with Mr B in December 2002. In this case, shareholder approval had been sought for Transaction 6 in November 2002.

Based on the above facts, and the application of the principles set out in sub-paragraph (a) above, Transactions 1 to 6 will be excluded from aggregation with Transaction 7 for purposes of determining whether any obligation is triggered as they have all been announced and shareholder approval has been sought for Transaction 6 based on aggregation with Transactions 1 to 5.

Illustration 3:**Facts:**

Listed issuer A Bhd entered into the following transactions with a related party, Mdm Y in 2002:

Transactions	Date of Transactions	Relevant Percentage Ratio
Transaction 1	February 2002	3%
Transaction 2	April 2002	2%

Based on the above and applying the principles set out in sub-paragraph (a) and (b), Transaction 2 will be aggregated with Transaction 1 thus requiring Transaction 2 to comply with paragraph 10.08(2) of the Listing Requirements. In this respect, information on Transaction 1 must be included in the circular issued which must include the information prescribed under Appendix 10B and Part A of Appendix 10D of the Listing Requirements.

Transactions	Date of Transactions	Relevant Percentage Ratio
Transaction 3	October 2002	3%

**Practice Note 14
Principle of Aggregation for Transactions**

In this case, the parties subsequently entered into Transaction 3 in October 2002. Transaction 3 will not be aggregated with Transactions 1 and 2 as shareholder approval for Transaction 2 has been obtained based on aggregation with Transaction 1. Transaction 3 on its own must be announced pursuant to paragraph 10.08(1) of the Listing Requirements.

BURSA MALAYSIA SECURITIES BERHAD**PRACTICE NOTE 17****CRITERIA AND OBLIGATIONS OF PN17 COMPANIES**

Details		Cross References
Effective date:	3 January 2005	Paragraphs 8.04, 16.02 and 16.11
Revision date:	3 August 2009	

1.0 Introduction

1.1 This Practice Note sets out, amongst others, the following:

- (a) the criteria in relation to the financial condition and level of operations of a listed issuer, which if triggered will give rise to an obligation for the listed issuer to comply with the provisions of this Practice Note; and
- (b) the requirements that must be complied with by a PN17 Company.

2.0 Criteria

2.1 Pursuant to paragraphs 8.04(2) of the Listing Requirements, where a listed issuer triggers any one or more of the following Prescribed Criteria it must comply with the provisions of paragraph 8.04 and this Practice Note:

- (a) the shareholders' equity of the listed issuer on a consolidated basis is 25% or less of the issued and paid-up capital (excluding treasury shares) of the listed issuer and such shareholders' equity is less than RM40 million;
- (b) receivers or managers have been appointed over the asset of the listed issuer, its subsidiary or associated company which asset accounts for at least 50% of the total assets employed of the listed issuer on a consolidated basis;
- (c) a winding up of a listed issuer's subsidiary or associated company which accounts for at least 50% of the total assets employed of the listed issuer on a consolidated basis;
- (d) the auditors have expressed an adverse or disclaimer opinion in the listed issuer's latest audited financial statements;
- (e) the auditors have expressed a modified opinion with emphasis on the listed issuer's going concern in the listed issuer's latest audited financial statements and the shareholders' equity of the listed issuer on a consolidated basis is 50% or less of the issued and paid-up capital (excluding treasury shares) of the listed issuer;
- (f) a default in payment by a listed issuer, its major subsidiary or major associated company, as the case may be, as announced by a listed issuer pursuant to Practice Note 1 and the listed issuer is unable to provide a solvency declaration to the Exchange;

Practice Note 17
Criteria and Obligations of PN17 Companies

- (g) the listed issuer has suspended or ceased -
- (i) all of its business or its major business; or
 - (ii) its entire or major operations,
- for any reasons whatsoever including, amongst others, due to or as a result of -
- (aa) the cancellation, loss or non-renewal of a licence, concession or such other rights necessary to conduct its business activities;
 - (bb) the disposal of the listed issuer's business or major business; or
 - (cc) a court order or judgment obtained against the listed issuer prohibiting the listed issuer from conducting its major operations on grounds of infringement of copyright of products etc; or
- (h) the listed issuer has an insignificant business or operations.

2.2 For the purposes of this Practice Note, unless the context otherwise requires -

- (a) **"shareholders' equity"** refers to the equity attributable to equity holders of the listed issuer;
- (b) **"total assets employed"** must be based on the listed issuer's latest audited or unaudited financial statements;
- (c) in relation to paragraph 2.1(g), **"major"** means such proportion that contributes or generates 70% or more of the listed issuer's revenue on a consolidated basis based on its latest annual audited or unaudited financial statements;
- (d) **"insignificant business or operations"** means business or operations which generates revenue on a consolidated basis that represents 5% or less of the issued and paid-up capital (excluding any redeemable preference shares and treasury shares) of the listed issuer ("**Capital**") based on its latest annual audited or unaudited financial statements.

For the purpose of computation, the following applies:

- (i) **"revenue on a consolidated basis"** comprises of the revenue of the listed issuer, its subsidiaries, as well as revenue from the listed issuer's associated companies, calculated on a proportionate basis, based on the listed issuer's equity holding in the associated companies; and
- (ii) where there is/are a change/changes to the Capital in that financial year, the weighted average Capital for that financial year must be used. The weighted average Capital means the total amount of the Capital at the beginning of the financial year, adjusted by the amount of increase or reduction in the Capital during that financial year multiplied by a time-weighting factor. The time-weighting factor is the number of days that the specific Capital is outstanding as a proportion of the total number of days in that financial year.

Example - Weighted Average of Capital for financial year ended 31 December 2xx1

Practice Note 17
Criteria and Obligations of PN17 Companies

		Issued and Paid up Capital (RM)
1 January 2xx1	Balance	60,000,000
1 June 2xx1	Issue of 10,000,000 new shares for cash	70,000,000
1 Dec 2xx1	Issue of 12,000,000 new shares for cash	82,000,000

Computation of weighted average:

$$(60,000,000 \times 151/365) + (70,000,000 \times 183/365) + (82,000,000 \times 31/365) = 66,882,185$$

- (e) “**net profit**” means the net profit after minority interest and excludes one off items, such as the following:
- (i) interest waiver;
 - (ii) negative goodwill credited to income statement;
 - (iii) gain/loss arising from sale of investment in associated companies/ subsidiaries or land and building; and
 - (iv) restructuring cost.

2.3 Paragraph 2.1(h) is not applicable to closed-end funds, real estate investment trusts, exchange-traded funds, infrastructure project corporations which have not completed and commenced operations on their infrastructure project(s) and special purpose acquisition companies.

3.0 Regularisation Plan

3.1 Pursuant to paragraph 8.04(3) of the Listing Requirements, a PN17 Company must regularise its condition by undertaking a regularisation plan. In this regard, a PN17 Company and its Principal Adviser must ensure that the regularisation plan -

- (a) is sufficiently comprehensive and capable of resolving all problems, financial or otherwise that had caused the PN17 Company to trigger the Prescribed Criteria;
- (b) enables the PN17 Company to regularise its financial condition and level of operations, such that the PN17 Company no longer triggers any of the Prescribed Criteria; and
- (c) is fair and reasonable to the PN17 Company and its shareholders and will increase shareholder value.

4.0 Disclosure obligations of the PN17 Company

4.1 Pursuant to paragraph 8.04(3)(b) of the Listing Requirements, a PN17 Company must announce to the Exchange -

- (a) on an immediate basis (“**First Announcement**”) upon the PN17 Company triggering one or more of the Prescribed Criteria -

Practice Note 17
Criteria and Obligations of PN17 Companies

- (i) that the listed issuer is a PN17 Company pursuant to this Practice Note;
 - (ii) ~~the~~ the listed issuer's obligations pursuant to this Practice Note;
 - (iii) the consequences of non-compliance with such obligations; and
 - (iv) the status of the listed issuer's regularisation plan or the status of its endeavours to formulate such a plan, whichever is applicable, or where neither a plan nor any endeavour to formulate such a plan has been undertaken, an appropriate negative statement to such effect;
- (b) within 3 months from the First Announcement, on whether the regularisation plan will result in a significant change in the business direction or policy of the PN17 Company;
 - (c) the status of its regularisation plan and the number of months to the end of the relevant timeframes referred to in paragraph 5.1 or 5.2 below, as may be applicable, on a monthly basis ("**Monthly Announcement**") until further notice from the Exchange;
 - (d) its compliance or non-compliance with a particular obligation imposed pursuant to this Practice Note, on an immediate basis;
 - (e) details of the regularisation plan which announcement must fulfill the requirements set out in paragraph 4.2 below ("**Requisite Announcement**"); and
 - (f) where the PN 17 Company fails to regularise its condition, the dates of suspension and de-listing of its listed securities, immediately upon notification of suspension and de-listing by the Exchange.

4.2 The Requisite Announcement must -

- (a) contain details of the regularisation plan and sufficient information to demonstrate that the PN17 Company is able to comply with all the requirements set out under paragraph 3.1 above after implementation of the regularisation plan;
- (b) include a timeline for the complete implementation of the regularisation plan; and
- (c) be announced by the PN17 Company's Principal Adviser.

4.3 Before a PN17 Company makes the Requisite Announcement, ~~it~~ it must ensure that -

- (a) all agreements to be entered into with third parties as part of the regularisation plan, have been duly executed by all parties to such agreements; and
- (b) where the regularisation plan involves a compromise or arrangement with the PN17 Company's creditors, the PN17 Company has taken reasonable steps to procure the agreement-in-principle of such creditors.

4.4 The Monthly Announcements must be made on the first market day of each month beginning with the month following the date of the First Announcement.

5.0 Obligation to Regularise

- 5.1 If a PN17 Company undertakes a regularisation plan which will result in a significant change in the business direction or policy of the PN17 Company, it must –

Practice Note 17
Criteria and Obligations of PN17 Companies

- (a) submit the plan to the SC for approval, within 12 months from the date of the First Announcement; and
 - (b) complete the implementation of the plan within such timeframe as may be prescribed by the SC.
- 5.2 If a PN17 Company undertakes a regularisation plan which will not result in a significant change in the business direction or policy of the PN17 Company, it must –
- (a) submit to the Exchange the plan and obtain the Exchange's approval to implement the plan within 12 months from the date of the First Announcement;
 - (b) complete the implementation of the plan within 6 months from the date the plan is approved by the Exchange. However, for cases which involve court proceedings, a PN17 Company has up to 12 months from the date the plan is approved by the Exchange, to complete the implementation of the plan; and
 - (c) record a net profit in 2 consecutive quarterly results immediately after the completion of the implementation of the plan. In this regard, the PN17 Company must ensure that the relevant quarterly results are subjected to a limited review by an external auditor before they are announced to the Exchange.

BURSA MALAYSIA SECURITIES BERHAD

PRACTICE NOTE 18

PERUSAL OF DRAFT CIRCULARS AND OTHER DOCUMENTS

Details		Cross References
Effective date:	3 January 2005	Paragraph 9.30
Revision date:	3 August 2009	

1.0 Introduction

1.1 Paragraph 9.30 of the Listing Requirements provides as follows:

- (1) *A listed issuer or offeror in an offer for sale of listed securities must submit to the Exchange for perusal, 1 draft copy of all circulars and other documents proposed to be sent to the holders of listed securities, within a reasonable time before printing together with a checklist showing compliance with the relevant parts of these Requirements.*
- (2) *Subparagraph (1) above does not apply to the following documents:*
 - (a) *an annual report;*
 - (b) *any document to be sent to holders of listed securities in relation to a take-over by or in respect of a listed issuer excluding circulars to be issued by a listed issuer, proposing to undertake or undertaking a take-over, to its securities holders pursuant to Chapter 10 of these Requirements;*
 - (c) *any document that is not prepared by the listed issuer or its advisers on its behalf;*
 - (d) *any circular to be issued by a listed issuer to its securities holders pursuant to paragraphs 10.11 and 10.14 of these Requirements, in relation to a transaction which will result in a significant change in the business direction or policy of the listed corporation and in relation to a qualifying acquisition proposed to be made by a SPAC; and*
 - (e) *such other document as prescribed by the Exchange subject to such requirements as may be imposed by the Exchange.*
- (3) *A listed issuer or offeror must not issue any of such documents referred to in subparagraph (1) above until the Exchange has confirmed in writing that it has no further comments on the documents.*
- (4) *Where an adviser is appointed by the listed issuer or offeror for the preparation and/or submission of the documents referred to in subparagraph (1) above to the Exchange, such adviser must also comply with subparagraphs (1) and (3) above."*

Practice Note 18
Perusal of Draft Circulars and Other Documents

- 1.2 This Practice Note sets out the relevant requirements on –
- (a) documents which are not required to be submitted to the Exchange for perusal; and
 - (b) documents which are subject to full review by the Exchange; and
 - (c) documents which are subject to limited review by the Exchange.
- 1.3 For the avoidance of doubt, in perusing circulars and documents pursuant to paragraph 9.30 of the Listing Requirements, the Exchange does not verify the information in the circular or document so perused. Listed issuers, their directors and advisers are responsible for the disclosure in these documents including ensuring the accuracy and completeness of the same pursuant to paragraph 9.32 of the Listing Requirements.

2.0 Documents that are not required to be submitted to the Exchange

- 2.1 For the purposes of paragraph 9.30(2)(e) of the Listing Requirements, the circulars or documents on any one or more of the following are not subject to paragraph 9.30(1) of the Listing Requirements, namely the perusal of the Exchange is not required before issuance:
- (a) ~~N~~otices of adjustments to warrants and convertible securities;
 - (b) ~~N~~otices of meetings;
 - (c) ~~B~~onus issues;
 - (d) ~~P~~urchase of own shares (including the ordinary resolution);
 - (e) ~~A~~amendments to or adoption of memorandum and articles of associations;
 - (f) ~~A~~amendments to trust deeds or deed polls;
 - (g) ~~I~~ncrease in authorised share capital; and
 - (h) ~~A~~ll other circulars to shareholders, which are not issued pursuant to a requirement to obtain shareholder approval, prescribed under the Listing Requirements.
- (collectively referred to as “**Exempt Circulars**”).

3.0 Obligations in relation to Exempt Circulars

- 3.1 Accordingly, the Exchange will no longer comment on any of the Exempt Circulars before issuance.
- 3.2 In this respect, an Exempt Circular must include a statement that Bursa Malaysia Securities Berhad has not perused the circular before its issuance.
- 3.3 Further, pursuant to paragraph 9.35 of the Listing Requirements, immediately upon issuance of the Exempt Circular to securities holders, a listed issuer must submit the requisite number of copies of the Exempt Circular to the Exchange together with a checklist showing compliance with the relevant parts of the Listing Requirements.
- 3.4 If the Exchange detects any non-compliance with the Listing Requirements subsequent to the issue of the Exempt Circular, the listed issuer and/or the adviser responsible for preparing the Exempt Circular may be subject to enforcement action by the Exchange.

Practice Note 18
Perusal of Draft Circulars and Other Documents

4.0 Documents subject to a limited review

4.1 The circulars or documents on the following subject-matters will be subjected to a limited review by the Exchange:

- (a) ~~I~~ssuance of securities for cash including but not limited to rights issue, private placement, restricted issue, special issue, issue of securities on a "bought deal" basis, allotments to directors (including allotment of ESOS options), major shareholders or persons connected with them which fall within paragraph 6.06 of the Listing Requirements;
- (b) ~~E~~mployee share schemes ("**ESOS**") including establishment of or amendments to by-laws, extensions of the duration of the scheme or termination of the scheme;
- (c) ~~O~~btaining or renewing shareholder mandate for Recurrent Related Party Transactions;
- (d) ~~N~~otice of maturity of securities;
- (e) ~~E~~xtensions of time for maturity/expiry of securities;
- (f) ~~S~~ubdivision or consolidation of shares;
- (g) ~~E~~arly redemption of securities, whether full or partial;
- (h) ~~N~~otice of subdivision or consolidation of shares; and
- (i) ~~N~~otice of share exchange, recall or reduction.

("Limited Review Circulars").

5.0 Obligations in respect of a Limited Review Circular

5.1 Pursuant to paragraph 9.30 of the Listing Requirements, a Limited Review Circular cannot be issued by a listed issuer until and unless the Exchange confirms in writing that it has no further comments on the document.

5.2 In this respect, a listed issuer must submit a draft of a Limited Review Circular pursuant to paragraph 9.30(1) of the Listing Requirements to the Exchange together with a checklist showing compliance with the relevant parts of the Listing Requirements.

5.3 In conducting a limited review, the Exchange will only focus on areas which in its opinion pose a high risk in terms of disclosure or compliance with the Listing Requirements.

5.4 Nothing in this Practice Note or the Listing Requirements will preclude the Exchange from conducting a full review in circumstance where it deems fit.

6.0 Documents subject to full review

6.1 The Exchange will continue to conduct a review of all circulars or documents not falling within the exclusions set out in paragraph 9.30(2) of the Listing Requirements including those on the following subject matters:

- (a) ~~R~~elated party transactions (excluding circulars in relation to shareholder mandate for Recurrent Related Party Transactions);

-
- (b) ~~V~~very substantial transactions;
 - (c) ~~D~~iversification of operations;
 - (d) ~~P~~rovision of financial assistance to associated companies;
 - (e) ~~S~~schemes of compromise, arrangement, amalgamation or reconstruction or restructuring schemes in general;
 - (f) ~~W~~ithdrawal of listing;
 - (g) ~~N~~on-related party transactions for which shareholder approval is required pursuant to paragraph 10.07 of the Listing Requirements;
 - (h) ~~L~~isting of subsidiaries;
 - (i) ~~C~~apital distribution, repayment or reduction;
 - (j) ~~M~~aterial dilution of a subsidiary falling under paragraph 8.21 of the Listing Requirements; and
 - (k) ~~A~~ny other documents as prescribed by the Exchange.

(“**Full Review Circulars**”)-

7.0 Obligations in respect of a Full Review Circular

- 7.1 In this respect, a listed issuer must submit a draft of a Full Review Circular pursuant to paragraph 9.30(1) of the Listing Requirements to the Exchange together with a checklist showing compliance with the relevant parts of the Listing Requirements.

BURSA MALAYSIA SECURITIES BERHAD

PRACTICE NOTE 19
PUBLIC SHAREHOLDING SPREAD

Details		Cross References
Effective date:	28 December 2006	Paragraphs 8.02 and 16.02
Revision date:	3 August 2009	

1.0 Introduction

1.1 This Practice Note prescribes -

- (a) the information that listed issuers must include in -
 - (i) an application to the Exchange for acceptance of a lower percentage of public shareholding spread pursuant to paragraph 8.02(1) of the Listing Requirements; and
 - (ii) an application to the Exchange for an extension of time to rectify the public shareholding spread;
- (b) disclosure requirements in the event a listed issuer -
 - (i) fails to comply with the required public shareholding spread; and
 - (ii) triggers a suspension pursuant to paragraph 16.02(1) and (2) of the Listing Requirements.

2.0 Application for acceptance of a lower percentage of public shareholding spread

2.1 Paragraphs 8.02(1) and 8.02(2) of the Listing Requirements provide that a listed issuer must ensure that at least 25% of its total listed shares (excluding treasury shares) or such lower percentage of shareholding spread as may be allowed by the Exchange, are in the hands of public shareholders ("**Required Public Shareholding Spread**").

2.2 The Exchange may, on the application by a listed issuer, accept a percentage lower than 25% of the total number of listed shares (excluding treasury shares) if it is satisfied that such lower percentage is sufficient for a liquid market in such shares ("**Acceptance of Lower Spread**").

2.3 In this respect, a listed issuer which proposes to apply for Acceptance of Lower Spread must include the following information in its application:

- (a) its issued and paid-up capital;
- (b) the number of public shareholders;
- (c) the percentage of public shareholding spread;

- (d) ~~A~~a statement as to whether the public shareholding spread includes a substantial shareholder who is deemed as “public” pursuant to paragraph 1.01 of the Listing Requirements (“**Shareholder**”) and if yes, the following details in relation to such Shareholder:
- (i) name; and
 - (ii) shareholdings in the listed issuer;
- (e) ~~T~~he average market capitalisation based on the daily closing price of the listed issuer’s shares during the last 12-month period;~~;~~
- (f) ~~T~~he percentage of listed shares (excluding treasury shares) held by the top 30 shareholders, the names and shareholdings of each of these shareholders; and
- (g) ~~T~~he percentage of public shareholding spread over the last 2 years.

3.0 Disclosure requirements in the event of non-compliance

3.1 Paragraph 8.02(3) of the Listing Requirements provides that a listed issuer must announce to the Exchange that it does not comply with the Required Public Shareholding Spread immediately upon it becoming aware of this (“**Non-Compliance Announcement**”).

3.2 The listed issuer must include the following information in its Non-Compliance Announcement:

- (a) ~~A~~a statement that the listed issuer does not comply with the public shareholding spread requirement set out in paragraph 8.02(1) of the Listing Requirements;
- (b) ~~T~~he percentage of public shareholding spread;~~;~~
- (c) ~~S~~steps taken or proposed to be taken by the listed issuer to comply with the Required Public Shareholding Spread (“**Rectification Plan**”) including the following:
 - (i) ~~T~~he tentative timeline in respect of the Rectification Plan; and
 - (ii) ~~T~~he status of the Rectification Plan; and
- (d) ~~W~~here the listed issuer has not formulated a Rectification Plan, the status of the listed issuer’s endeavours to formulate such a plan or where a Rectification Plan has not been formulated and/or if no endeavours have been taken to formulate such a plan, an appropriate negative statement to such effect.

3.3 After the Non-Compliance Announcement, a listed issuer which does not comply with the Required Public Shareholding Spread must announce the status of its efforts to comply with the Required Shareholding Spread (“**Status Announcement**”). The listed issuer must make the Status Announcements for each quarter of its financial year simultaneously with the quarterly reports and in any event, not later than 2 months after the end of each quarter of a financial year.

3.4 The listed issuer must include the following information in the Status Announcement:

- (a) ~~T~~he information prescribed in paragraph 3.2 above; and
- (b) ~~A~~a statement as to whether an extension of time for compliance has been granted by the Exchange and if so, the following:

- (i) the duration of extension granted;
- (ii) the expiry date of the extension.

3.5 For the avoidance of doubt, upon compliance with the Required Public Shareholding Spread or Acceptance of Lower Spread by the Exchange, the listed issuer is no longer required to make any Status Announcement.

4.0 Applications for extensions of time for compliance and related disclosure requirements

4.1 Pursuant to paragraph 8.02(4) of the Listing Requirements, a listed issuer which does not comply with the Required Public Shareholding Spread may apply to the Exchange for an extension of time to rectify its public shareholding spread.

4.2 In this respect, a listed issuer must include the following information in the application for extension of time:

- (a) ~~T~~he issued and paid-up capital;
- (b) ~~T~~he percentage of public shareholding spread;
- (c) ~~T~~he number of public shareholders;
- (d) ~~W~~hether the public shareholding spread includes a Shareholder. If yes, the following details in relation to such Shareholder:
 - (i) name; and
 - (ii) shareholdings in the listed issuer;
- (e) ~~T~~he average market capitalisation based on the daily closing price of the listed issuer's shares during the last 12-month period~~;~~
- (f) ~~T~~he reason for non-compliance with the Required Public Shareholding Spread;
- (g) ~~T~~he percentage of listed shares (excluding treasury shares) held by the top 30 shareholders, the names and shareholdings of each of these shareholders;
- (h) ~~I~~f there is a Rectification Plan, an elaboration of the same and its status;
- (i) ~~W~~here the listed issuer has not formulated a Rectification Plan, the status of the listed issuer's endeavours to formulate such a plan;
- (j) ~~I~~f there has been no progress in relation to items (h) and (i) above during the previous extension of time, the listed issuer must also explain the reason for the lack of progress;
- (k) ~~T~~he reason for failure to rectify the public shareholding spread within the previous extension of time, if any; and
- (l) ~~J~~ustification for the extension of time sought.

4.3 Where an extension of time to rectify the public shareholding spread has been granted by the Exchange, the listed issuer must immediately announce to the Exchange the extension of time granted. The listed issuer must include the following information in the announcement:

-
- (a) **Aa** statement that an extension of time for compliance has been granted by the Exchange and the following details:
- (i) the duration of extension granted;
 - (ii) the expiry date of the extension; and
- (b) **Ft**he information prescribed in paragraph 3.2(b) to (d) above.
- 4.4 Where an extension of time has not been granted by the Exchange, the listed issuer must immediately announce the decision of the Exchange. The listed issuer must include the following information in the announcement:
- (a) **Aa** statement that an extension of time for compliance has not been granted by the Exchange;
- (b) **Ft**he information prescribed in paragraph 3.2(b) to (d) above; and
- (c) **Aa** statement that the Exchange may -
- (i) take or impose for a breach of paragraph 8.02(1) of the LR any type of action or penalty pursuant to paragraph 16.19 of the LR; and
 - (ii) suspend trading in its securities pursuant to paragraph 16.02 of the LR.
- 5.0 Suspension where the public shareholding spread is 10% or less and related disclosure requirements**
- 5.1 Pursuant to paragraph 16.02(2) of the Listing Requirements, where the public shareholding spread of a listed issuer is 10% or less of the total number of listed shares (excluding treasury shares) ("**Threshold**"), a suspension will be imposed by the Exchange.
- 5.2 The suspension in trading imposed by the Exchange under paragraph 5.1 above will only be uplifted upon full compliance with the Required Public Shareholding Spread or as may be determined by the Exchange.
- 5.3 Where a listed issuer becomes aware, either in conjunction with the preparation of its semi-annual returns or otherwise, that its public shareholding spread triggers the Threshold, the listed issuer must immediately announce this to the Exchange.
- 5.4 The listed issuer must include the following information in the above announcement:
- (a) **Ft**he public shareholding spread;
- (b) **Aa** statement that pursuant to paragraph 16.02(2) of the Listing Requirements, trading in its securities will be suspended immediately upon the expiry of 30 market days from the date of the immediate announcement in view that the public shareholding spread of the listed issuer is 10% or below of the total number of listed shares (excluding treasury shares);
- (c) **Ft**he date suspension will be effected (i.e. the market day immediately following the expiry of 30 market days from the date of the immediate announcement);
- (d) **Aa** statement that once the suspension pursuant to paragraph 16.02(2) of the Listing Requirements is effected, it will only be uplifted by the Exchange upon full compliance with the Required Public Shareholding Spread or as may be determined by the Exchange;

Practice Note 19
Public Shareholding Spread

- (e) ~~T~~he steps taken or proposed to be taken by the listed issuer (if any) to increase its public shareholding spread to above 10% before the date suspension is to be effected;
- (f) ~~A~~n explanation of the Rectification Plan (if any);
- (g) ~~T~~he tentative timeline for the steps referred to in subparagraph (e) above and the Rectification Plan; and
- (h) ~~W~~here neither the steps referred to in subparagraph (e) above nor a Rectification Plan has been formulated and/or if no endeavours have been taken to formulate such steps or a Rectification Plan, an appropriate negative statement to such effect.

BURSA MALAYSIA SECURITIES BERHAD
PRACTICE NOTE 20**TRADING HALT**

Details		Cross References
Effective date:	3 September 2007	Paragraph 16.04
Revision date:	3 August 2009	

1.0 Introduction

- 1.1 Pursuant to paragraph 16.04 of the Listing Requirements, a trading halt may be imposed on the listed issuer's securities by the Exchange upon release of a material announcement by the listed issuer before or during trading hours.
- 1.2 The purpose of trading halt is to enable dissemination of the material information disclosed and facilitate the evaluation of such information.
- 1.3 This Practice Note sets out the following:
- (a) the types of material announcements which may warrant trading halt; and
 - (b) the periods of trading halt.
- 1.4 Nothing in this Practice Note will be read to restrict the powers of the Exchange to suspend the trading of the listed issuer's securities pursuant to paragraph 16.02 of the Listing Requirements.

2.0 Material announcement which may warrant trading halt

- 2.1 For the purpose of paragraph 16.04 of the Listing Requirements, an announcement relating to any of the following matters will be regarded as a material announcement:
- (a) an interim financial reports;
 - (b) a bonus issue or other fund raising exercise;
 - (c) a subdivision of shares or consolidation by the listed issuer;
 - (d) a transaction requiring an announcement to be made under Chapter 10 of the Listing Requirements;
 - (e) a declaration of a dividend or distribution;
 - (f) a change in the controlling shareholder of the listed issuer;
 - (g) a notice of take-over being served on a listed issuer;

- (h) commencement of winding-up proceedings against the listed issuer or any of its subsidiaries or major associated companies;
- (i) rejection of the corporate proposals previously announced by the shareholders or regulatory authorities;
- (j) the prospects, revenue or profit estimate, forecast, projection or internal targets of the listed issuer and any circumstances or development which are likely to materially affect the results or outcome of the same;
- (k) any clarifying announcement pursuant to Chapter 9 of the Listing Requirements including the response to a rumour or report or unusual market activity; or
- (l) any other announcements which the Exchange considers material pursuant to paragraph 9.03(2) of the Listing Requirements.

3.0 Periods of trading halt

- 3.1 Where the material announcement is released during trading hours, the trading halt imposed by the Exchange will be for 1 hour or until the end of that trading session, whichever is the earlier. The periods of trading halt that may be imposed by the Exchange are as follows:

	Time for Release of Material Announcement	Trading Halt Period
(i)	Before the commencement of trading at 9.00 a.m.	9.00 a.m. to 10 a.m.
(ii)	9.00 a.m. to 11.00 a.m.	1 hour from the time the material announcement is released
(iii)	After 11.00 a.m. and before 12.30 noon	From the time the material announcement is released until 12.30 noon
(iv)	12.30 p.m. until 1.30 p.m.	No trading halt will be imposed
(v)	After 1.30 p.m. until 2.30 p.m.	2.30 p.m. to 3.30 p.m.
(vi)	After 2.30 p.m. until 3.30 p.m.	1 hour from the time the material announcement is released
(vii)	After 3.30 p.m. and before 5.00 p.m.	From the time the material announcement is released until 5.00 p.m.

- 3.2 Notwithstanding paragraph 3.1 above, the Exchange may, at its discretion, suspend the trading of the listed issuer's securities for the entire day or such period as the Exchange deems it appropriate.
- 3.3 For the avoidance of doubt, the periods of trading halt as stated in this Practice Note are not applicable to the securities of a listed issuer suspended pursuant to a request for suspension under paragraph 16.03 of the Listing Requirements and Practice Note 2. Hence, the securities of a listed issuer which are suspended will not be quoted on the same day of the release of the relevant announcement.

BURSA MALAYSIA SECURITIES BERHAD**PRACTICE NOTE 21****LISTING PROCEDURES FOR INITIAL ADMISSION**

Details	Cross References
Effective date: 3 August 2009	Paragraphs 3.02, 4.04, 4.09, 4.14, 4A.06, 4A.20 , 4A.39 , 8.16 and 15.03

1.0 Introduction

1.1 This Practice Note sets out the following requirements in relation to an application for admission under paragraph 3.02 of the Listing Requirements:

- (a) the procedures for admission;
- (b) the listing application form and supporting documents;
- (c) the undertakings and confirmation by an applicant and its directors; and
- (d) other relevant requirements.

1.2 The requirements set out in this Practice Note also apply to a listed corporation that undertakes a corporate proposal which will result in a significant change in the business direction or policy of a listed corporation. However, when such a listed corporation issues new securities, the listed corporation must also comply with the requirements under Practice Note 28, where applicable.

2.0 Procedures relating to admission

2.1 The following procedures apply to the admission of an applicant to the Official List, with the necessary modifications, as may be applicable:

- (a) applicant submits a listing application to the SC;
- (b) SC approves listing;
- (c) applicant files with the Exchange a listing application together with supporting documents;
- (d) applicant files the final copy of prospectus with the relevant authorities;
- (e) Exchange grants approval for the admission of securities;
- (f) applicant -
 - (i) issues the prospectus or introductory document and the offer period opens, if the listing entails an offer of securities to the public;

- (ii) advertises the prospectus or introductory document;
 - (iii) provides the Exchange with such number of copies of the printed prospectus or introductory document as may be determined by the Exchange from time to time; and
 - (iv) announces to the Exchange, the indicative timetable of the initial public offering containing the information set out in paragraph 8.1 below;
- (h) if the listing entails an offer of securities to the public, the applicant announces the level of subscription and the basis of allocation;
- (i) applicant issues securities and notices of allotment;
- (j) applicant announces to the Exchange the relevant information in accordance with paragraph 8.2 below; and
- (k) securities are admitted to the Official List and quoted on the Exchange.

3.0 Listing application form and supporting documents

3.1 An applicant must file with the Exchange a listing application which consists of the following:

- (a) the application, in the form of Part A of Annexure PN21-A; and
- (b) the supporting documents specified in Part B of Annexure PN21-A.

4.0 Undertakings and confirmation

4.1 An applicant must give the Exchange an undertaking in the form of Annexure PN21-B.

4.2 An applicant must ensure that -

- (a) every one of its directors gives the Exchange an undertaking in the form of Annexure PN21-C; and
- (b) every director who is or has been appointed as an independent director gives the Exchange a letter in the form of Annexure PN21-D.

5.0 Notification/Advertisement of securities prescribed by the Exchange to be deposited with the Depository

5.1 In relation to the prescription by the Exchange of the securities of the applicant to be deposited with the Depository pursuant to section 14 of the Securities Industry (Central Depositories) Act 1991 ("**Prescription**"), the applicant must submit to the Exchange either one of the following:

- (a) a written confirmation to the Exchange that the information set out in its register including the addresses of its shareholders are updated and accurate as at a date not more than 14 days before –
 - (i) the issuance date of the prospectus or introductory document; or

-
- (ii) the proposed books closing date,
as the case may be, for purposes of notification to its shareholders of the Prescription; or
 - (b) where the applicant is unable to provide the confirmation set out in sub-paragraph (a) above, payment to the Exchange, as stipulated in the Schedule of Fees for the advertisement charges incurred or to be incurred by the Exchange pursuant to section 14(2) of Securities Industry (Central Depositories) Act 1991 in relation to the Prescription.
- 5.2 The applicant must submit the confirmation referred to in paragraph 5.1(a) above 3 clear market days before –
- (a) the issuance date of the prospectus or introductory document; or
 - (b) the proposed books closing date,
- as the case may be.

6.0 Listing of issued and unissued securities

- 6.1 An applicant must apply for approval to list only –
- (a) that part of the securities which have been issued; and
 - (b) securities to be issued in connection with the listing application.
- 6.2 If an additional unissued amount is reserved for subsequent issuance for a specific purpose, an applicant must apply for an approval to add that amount to the Official List in the future for that specific purpose.
- 6.3 An applicant must not apply for an approval for the listing of any security which is not reserved for subsequent issuance for a specific purpose.
- 6.4 An applicant must submit an application for quotation for such reserved amount for which approval has been granted pursuant to subparagraph 6.1(b) above, upon actual issuance of such amount in accordance with the provisions of Chapter 6 of the Listing Requirements.

7.0 Classification of an applicant

- 7.1 An applicant must propose to the Exchange its classification into any one of the sectors prescribed by the Exchange, in accordance with the criteria prescribed by the Exchange.
- 7.2 The applicant must furnish to the Exchange a proposal of its classification made in accordance with paragraph 7.1 above in a form prescribed by the Exchange.
- 7.3 The classification is subject to the approval of the Exchange. The Exchange may in its absolute discretion classify the applicant into such other sector as it deems fit.

8.0 Announcements to the Exchange

- 8.1 An applicant must announce the indicative timetable of the initial public offering as follows upon the issuance of the prospectus and before the listing date:

- (a) the opening and closing date of the offer period;
- (b) the balloting date;
- (c) the allotment date of the initial public offering securities; and
- (d) the tentative listing date.

8.2 An applicant must immediately announce the following to the Exchange upon receipt of confirmation from the Depository that the securities are ready to be credited into the respective securities accounts:

- (a) actual date of listing;
- (b) enlarged issued and paid-up capital of the listed issuer indicating the number of shares and their par value, if any;
- (c) stock short name, stock code, ISIN code; and
- (d) sector and market under which the securities will be listed.

ANNEXURE PN21-A

PART A

Listing application for admission of securities

(paragraph 3.1—(a); paragraph 3.1(a) of Practice Note 24; paragraph 4A.06 of the Listing Requirements)

Please tick wherever applicable. If not applicable, please indicate “N/A”
[You may tick more than one box, where applicable]

Deleted as appropriate

1.	Name of Company	
2.	Types of corporate proposal	(a) Initial Public Offerings (“IPO”) <input type="checkbox"/>
		(b) Proposals resulting in a significant change in business direction or policy of the listed issuer (“RTO”) <input type="checkbox"/>
	Details of proposals which form part of the IPO/ RTO	
	Number & types of securities applied for listing, par value & issue price (if any)	
3.	Currency denomination which the new securities will be listed and quoted	(a) Ringgit Malaysia (“RM”) <input type="checkbox"/> (b) Others : (Please indicate) _____ _____ In the event the new securities are listed and quoted in currencies other than RM, whether the approval of the Controller of Foreign Exchange has been obtained-? _____ Yes <input type="checkbox"/> _____ No <input type="checkbox"/>
34.	INITIAL PUBLIC OFFERINGS (“IPO”)	
34A	Proforma Public Shareholdings Spread	(a) ORDINARY SHARES []% and [] public shareholders

		(b) <u>CONVERTIBLE SECURITIES/PREFERENCE SHARES</u> [] holders
34B	Tentative listing date (to specify)	
34C	Top 3 preferences for S stock S short N name (limited to 7 characters)	(a) Option 1: (b) Option 2: (c) Option 3:
34D	Undertakings for IPO proposals	We undertake the following: (a) the return of allotment will be filed with the Registrar of Companies pursuant to the Companies Act, 1965 or in relation to a foreign corporation, the relevant document showing its latest issued and paid-up capital will be filed with the relevant authority pursuant to the laws of the place of incorporation; (b) all notices of allotment will be issued and despatched to all successful applicants before the date of listing and quotation of the securities; (c) the securities will rank pari passu in all respects with each other; (d) the public shareholding spread based on the enlarged issued and paid-up capital of the applicant will be in compliance with paragraph 3.06 of Bursa Malaysia Securities Berhad (" Exchange ") Main Market Listing Requirements of (" LR "); (e) a schedule of actual distribution of the public shareholding spread mentioned in item (d) above, as per Part B(1)(d) of Annexure PN21-A, will be furnished to the Exchange on the first day of listing; (f) where the SC imposes a moratorium on the sale of securities, the following information on the moratorium will be submitted to the Depository before the listing: (i) the names of securities holders; (ii) the number of securities; (iii) the date(s) of expiry of the moratorium; (g) all conditions, including conditions imposed by the relevant authorities, if any, which are required to be met before the listing and quotation of the securities will be met; (h) all allotment information of new securities will be submitted to the Depository for the crediting of securities into the respective securities holders' accounts;

Annexure PN21-A
Listing application for admission

		<p>(i) there are no circumstances or facts which have the effect of preventing or prohibiting the issuance, listing and/or quotation of the securities including any order, injunction or any other directive issued by any court of law;</p> <p>(j) to immediately inform the Exchange upon becoming aware, after submission of the listing application, that the applicant has failed to meet any of the undertakings referred to in paragraphs (a) to (h) or of any circumstances or facts referred to in paragraph (i) above;</p> <p>(k) to announce to the Exchange the relevant information in accordance with paragraph 8.1 and 8.2 of Practice Note 21; and</p> <p>(l) to announce the latest quarterly results, where applicable, at least 2 market days before the date of listing.</p>
45.	PROPOSALS RESULTING IN SIGNIFICANT CHANGE IN BUSINESS DIRECTION OR POLICY OF THE LISTED CORPORATION (“RTO”)	
45A	Confirmation on Practice Note 16	<p>(a) The applicant is a Cash Company Yes <input type="checkbox"/> No <input type="checkbox"/></p> <p>(b) The proposal in item (2) #is/are a proposal to regularise the Cash Company’s condition as referred to in paragraph 8.03(5) of the LR Yes <input type="checkbox"/> No <input type="checkbox"/></p>
45B	Confirmation on Practice Note 17 (“PN17”)	<p>(a) The applicant is a PN17 Company Yes <input type="checkbox"/> No <input type="checkbox"/></p> <p>(b) The proposal in item (2) #is/are a plan to regularise the PN17 Company’s condition as referred to in paragraph 8.04(3) of the LR Yes <input type="checkbox"/> No <input type="checkbox"/></p>
45C	Ranking of the new securities	<p>The new securities #will/will not be listed and quoted as the existing listed securities of the same class.</p> <p>If the new securities will be separately quoted on listing date, details of the non-entitlement(s):</p> <p>_____</p> <p>_____</p>
45D	Conditionality of Proposals/ Pricing	<p>(a) The issue price #is/ is not conditional upon any other proposal</p> <p>(b) This proposal #is/is not conditional upon any other proposal</p> <p>If in the affirmative, to provide details of the other corporate exercises, including the estimated time frame for completion:</p>

45E	Proforma Public Shareholding Spread	<p>(a) ORDINARY SHARES</p> <p>[]% and [] public shareholders</p> <p>(b) CONVERTIBLE SECURITIES/ PREFERENCE SHARES</p> <p>[] holders</p>
45F	Confirmation	We confirm that the public shareholding spread based on the enlarged issued and paid-up capital of the applicant will be in compliance with paragraph 3.06 of the LR.
45G	Undertakings for RTO	<p>We undertake the following:</p> <p>(a) the return of allotment will be filed with the Registrar of Companies pursuant to the Companies Act, 1965 or in relation to a foreign corporation, the relevant document showing its latest issued and paid-up capital will be filed with the relevant authority pursuant to the laws of the place of incorporation;</p> <p>(b) all notices of allotment will be issued and despatched to the entitled holders as expeditiously as possible and in any event, not later than 4 market days after the date of listing and quotation;</p> <p>(c) all conditions, including conditions imposed by the relevant authorities, if any, which are required to be met before the listing and quotation of the securities, will be met;</p> <p>(d) there are no circumstances or facts which have the effect of preventing or prohibiting the issuance, listing and/or quotation of the securities including any order, injunction or any other directive issued by any court of law;</p> <p>(e) to immediately inform the Exchange upon becoming aware, after submission of the listing application, that the listed issuer has failed to meet any of the above undertakings referred to in paragraphs (a) to (c) or of any circumstances or facts referred to in paragraph (d) above; and</p> <p>(f) to announce to the Exchange the relevant information in accordance with paragraph 13.2 of Practice Note 28, where applicable.</p>
56.	SHARES SCHEME FOR EMPLOYEES (“ESOS”) (AS PART OF AN IPO PROPOSAL)	
56A	Confirmation	We confirm that the ESOS is in full compliance with Part G, Chapter 6 of the LR
	[Authorised signatory of the Principal Adviser] Name:	[Authorised signatory of the applicant] Name:

**Annexure PN21-A
Listing application for admission**

Designation:
Date:

Designation:
Date:

PART B**Documents to be filed with a listing application**

(paragraphs 3.1(b); [paragraphs 3.1\(b\) and 7.1\(b\) of Practice Note 23](#); [paragraph 3.1\(b\) of Practice Note 24](#); [paragraphs 4.04 and 4A.06](#) of the Listing Requirements)

- (1) An applicant must file the following documents in support of a listing application:
- (a) a copy each of the articles of association and all amendments to-date and a copy each of the certificate of incorporation, certificate of change of status and certificate of change of name, if any, together with a letter of compliance pursuant to paragraph 2.12 and a checklist showing compliance with the relevant provisions of Chapter 7 of the Listing Requirements;
 - (b) a copy of the draft prospectus submitted to the relevant authorities or the draft introductory document;
 - (c) a specimen copy of each denomination of certificates of the class to be listed. If transfer offices and registrars are maintained in more than one place, one specimen of each denomination of certificates used in each office (see Chapter 8 of the Listing Requirements for form and content of certificates);
 - (d) a statement on the percentage of the total number of shares for which listing is sought which are held by the public, the number of public shareholders and a pro forma distribution of the shares in the following format:

<i>Particulars</i>	<i>No of Shares</i>	<i>No of shareholders</i>	<i>Percentage %</i>
<i>Issued and paid-up capital</i>			
<i>Less:</i>			
<i>Directors of the applicant and its subsidiaries and/or associated companies</i>			
<i>Substantial shareholders of the applicant (except where such shareholder may be included as "public")</i>			
<i>Associates of directors or substantial shareholders of the applicant</i>			

**Annexure PN21-A
Listing application for admission**

*Shareholders
holding less than
100 shares* -----

Public shareholdings

- (e) a letter of undertaking in the form of Annexure PN21-B duly executed by the applicant together with a certified true extract of the applicant's board of directors' resolution authorising the signatory;
 - (f) a letter of undertaking in the form of Annexure PN21-C duly executed by each director of the applicant;
 - (g) a letter in the form of Annexure PN21-D duly executed by each independent director of the applicant;
 - (h) a letter from the applicant's Principal Adviser confirming all approvals of relevant authorities have been obtained;
 - (i) a copy each of all letters of approval from the relevant authorities;
 - (j) a proposal as to classification of the applicant in a specific sector in the prescribed form;
 - (k) a letter of notification issued by the applicant for the appointment of stabilizing manager that includes -
 - (i) where the stabilizing manager is a Participating Organisation, the name, business address and contact person of the Participating Organisation, name of the Capital Markets Services Representative's License holder that will be conducting the stabilizing action;
 - (ii) where the stabilizing manager is not a Participating Organisation, the name and business address of the person appointed as the stabilizing manager and a contact person, the name of the Participating Organization and the Capital Markets Services Representative's License holder that has been appointed to conduct the stabilizing action;
 - (iii) where a stabilizing manager is appointed outside Malaysia, the name, address and contact person of the stabilizing manager appointed at that jurisdiction, the name, address and contact person of the Participating Organisation appointed in Malaysia to conduct the stabilizing action in Malaysia, along with the name of the Capital Markets Services Representative's License holder that will be conducting the stabilizing action in Malaysia; or
 - (iv) an undertaking to inform the Exchange of any subsequent change of the stabilizing manager, Capital Markets Services Representative's License holder or Participating Organisation, where applicable, immediately upon such change; and
 - (l) a cheque drawn to the order of Bursa Malaysia Securities Berhad for the listing fees (see Schedule of Fees for computation of amount) together with a copy of the details of the computation of the amount of listing fees payable.
- (2) If any of the above documents are not filed because they are not applicable or available in any case, an applicant must submit a separate exhibit explaining why such documents are not applicable or available.

**Annexure PN21-A
Listing application for admission**

[End of Annexure]

ANNEXURE PN21-B

Undertaking by an applicant

(paragraph 4.1; [paragraph 12.1 of Practice Note 23](#); [paragraphs 4.1 and 7.1 of Practice Note 24](#); paragraph 4.14 of the Listing Requirements)

To

Bursa Malaysia Securities Berhad
Exchange Square
Bukit Kewangan
50200 Kuala Lumpur

Compliance with Main Market Listing Requirements and Rules of Bursa Malaysia Securities Berhad (“**Bursa Securities**”)

In consideration of Bursa Securities approving the application for admission of (“**Corporation**”) to the Official List of Bursa Securities (“**Official List**”) and for official quotation of the securities described in the Corporation’s listing application WE ACKNOWLEDGE that the Corporation shall remain on the Official List, and official quotation of any of the Corporation’s securities shall continue only during the pleasure of Bursa Securities.

WE FURTHER UNDERTAKE AND AGREE to comply with Bursa Securities Main Market Listing Requirements and the Rules of Bursa Securities, including any amendment as may be made from time to time, insofar as the same shall apply to the Corporation.

[**This Undertaking is deemed to have been made in Malaysia and the construction, validity and performance of this Undertaking are governed in all respects by the laws of Malaysia and WE irrevocably submit to the jurisdiction of the Malaysian Courts.](#)

The above Undertaking has been signed by me as [title] of[name of Corporation] pursuant to authority granted to me by resolution of the board of directors of the Corporation on

Date:

Signature:

Name:

[** Applicable to a foreign applicant only.](#)

[_-End of Annexure-_]

ANNEXURE PN21-C

Undertaking by a director of an applicant/listed corporation
(paragraphs 4.2(a); paragraphs 12.2(a) and 7.2 of Practice Note 23; paragraph 4.2(a) of Practice Note 24; paragraphs 4.14, 4A.39, 8.16 and 15.03(1) of the Listing Requirements)

To

Bursa Malaysia Securities Berhad
Exchange Square
Bukit Kewangan
50200 Kuala Lumpur

Compliance with Main Market Listing Requirements

I,[name ~~and NRIC number~~ of director], am a director of[name(s) of applicant/listed corporation(s) ("**Corporation(s)**") which #has/have submitted an application to Bursa Malaysia Securities berhad ("**Bursa Securities**") to be admitted to the Official List of Bursa Securities ("**Official List**") / #is/are listed on the Official List of Bursa Securities.

In consideration of Bursa Securities #approving the Corporation's application for admission to the Official List / allowing the continued listing of the Corporation(s) on the Official List, I UNDERTAKE AND AGREE to comply with Bursa Securities Main Market Listing Requirements including any amendment as may be made from time to time, insofar as the same shall apply to me as a director of the Corporation(s).

**This Undertaking is deemed to have been made in Malaysia and the construction, validity and performance of this Undertaking are governed in all respects by the laws of Malaysia and I irrevocably submit to the jurisdiction of the Malaysian Courts.

Yours faithfully,

.....

Name:

NRIC No. (Old & New):

**Passport No. & Country of Issuance:

Designation:

Date:

Delete as appropriate

** Applicable to a foreign director only.

[End of Annexure]

ANNEXURE PN21-D

Letter of confirmation by an independent director of an applicant/listed corporation
(paragraph 4.2(b); paragraph 12.2(b) of Practice Note 23; paragraph 4.2(b) of Practice Note 24;
paragraphs 4.14, 4A.39, 8.16 and 15.03(2) of the Listing Requirements)

To

Bursa Malaysia Securities Berhad
Exchange Square
Bukit Kewangan
50200 Kuala Lumpur

Confirmation of "independence" pursuant to Main Market Listing Requirements

I, [name ~~and NRIC number~~ of director], am a director of
[name(s) of applicant/listed corporation(s) which #has/have submitted an application to Bursa
Malaysia Securities Berhad ("**Bursa Securities**") to be admitted to the Official List of Bursa Securities
/#is/are listed on the Official List of Bursa Securities.

I CONFIRM AND DECLARE that I am an independent director as defined under paragraph 1.01 of
Bursa Securities Main Market Listing Requirements.

**This Confirmation is deemed to have been made in Malaysia and the construction, validity and
performance of this Confirmation are governed in all respects by the laws of Malaysia and I
irrevocably submit to the jurisdiction of the Malaysian Courts.

Yours faithfully,

.....

Name:

NRIC No. (Old & New):

**Passport No. & Country of Issuance:

Designation:

Date:

Delete as appropriate.

** Applicable to a foreign independent director only.

[End of Annexure]

BURSA MALAYSIA SECURITIES BERHAD**PRACTICE NOTE 22****TRANSFER OF LISTED CORPORATIONS TO THE MAIN MARKET**

Details		Cross References
Effective date:	3 August 2009	Paragraph 3.09

1.0 Introduction

- 1.1 This Practice Note sets out the procedures and other requirements relating to an application to transfer a listed corporation from the ACE Market to the Main Market under paragraph 3.09.

2.0 Procedures relating to transfer

- 2.1 The following procedures apply to the transfer of a listed corporation to the Main Market, with the necessary modifications, as may be applicable:
- (a) listed corporation immediately announces the transfer to the Exchange upon approval of its board of directors;
 - (b) listed corporation submits an application to the SC;
 - (c) SC approves the transfer;
 - (d) listed corporation files with the Exchange a transfer application together with supporting documents;
 - (e) Exchange grants approval for the transfer;
 - (f) listed corporation files the final copy of prospectus with the relevant authorities, where applicable;
 - (g) listed corporation issues the prospectus or introductory document, places a box advertisement and announces to the Exchange the transfer date; and
 - (h) securities transferred to the Main Market 2 clear market days after the issuance of the prospectus or introductory document, placement of box advertisement and announcement to the Exchange.

3.0 Transfer application form and supporting documents

- 3.1 A listed corporation seeking a transfer to the Main Market must submit to the Exchange, a transfer application which consists of the following:
- (a) the application, in the form of Part A of Annexure PN22-A;

Practice Note 22
Transfer of Listed Corporations to the Main Market

- (b) the information and supporting documents specified in Part B of Annexure PN22-A; and
- (c) a resolution of the listed corporation's board of directors approving and authorising the application for transfer.

4.0 Undertakings and confirmation

4.1 An applicant must give the Exchange an undertaking in the form of Annexure PN22-B.

4.2 An applicant must ensure that -

- (a) every one of its directors gives the Exchange an undertaking in the form of Annexure PN22-C; and
- (b) every director who is or has been appointed as an independent director gives the Exchange a letter in the form of Annexure PN22-D.

ANNEXURE PN22-A

PART A

Transfer application
(paragraph 3.1(a))

Please tick wherever applicable. If not applicable, please indicate "N/A"
[You may tick more than one box, where applicable]

Delete as appropriate

1.	Name of Company	
2.	Type of securities	Transfer from the ACE Market to the Main Market of Bursa Malaysia Securities Berhad (a) Ordinary shares <input type="checkbox"/> (b) Warrants <input type="checkbox"/> (c) Loan Stocks <input type="checkbox"/>
3.	SC's approval	Approval from the SC has been obtained <input type="checkbox"/>
4.	Public Shareholdings Spread	[]% and [] public shareholders
5.	Tentative Transfer Date (to specify)	
6.	Conditionality of Transfer	The Transfer is/is not conditional upon any other corporate proposals. If in the affirmative, to provide details of the other corporate exercises, including the estimated time frame for completion: _____
7.	Confirmation	We confirm the following: (a) the composition of the board of directors of the listed corporation complies with the requirements of paragraph 15.02 of Bursa Malaysia Securities Berhad Main Market Listing Requirements ("LR"); (b) the composition of the audit committee of the listed corporation complies with the requirements of paragraphs 15.09 and 15.10 of the LR; and (c) the public shareholding spread based on the enlarged issued and paid-up capital of the applicant is in compliance with paragraph 3.06 of the LR.

8.	Undertaking	<p>We undertake the following:</p> <p>(a) Aa box advertisement of the transfer will be advertised and the introductory document will be issued and dispatched to the shareholders 2 clear market days before the transfer date;</p> <p>(b) Aall conditions, including conditions imposed by the relevant authorities, if any, which are required to be met before the transfer to the Main Market, will be met; and</p> <p>(c) There are no circumstances or facts which have the effect of preventing or prohibiting the transfer to the Main Market including any order, injunction or any other directive issued by any court of law.</p>
<p>_____ [Authorised signatory of the Principal Adviser] Name: Designation: Date:</p>		<p>_____ [Authorised signatory of the listed corporation] Name: Designation: Date:</p>

PART B

Information and documents to be disclosed and filed with a transfer application
(paragraph 3.1(b)(i))

- (1) A listed corporation must disclose or file the following information or documents in support of a transfer application:
- (a) a copy of the prospectus registered with the relevant authorities or the introductory document or where this is not available, a copy of the draft prospectus submitted to the relevant authorities or the draft introductory document;
 - (b) a letter of undertaking in the form of Annexure PN22-B duly executed by the listed corporation together with a certified true extract of the resolution of the listed corporation's board of directors authorising the signatory;
 - (c) a letter of undertaking in the form of Annexure PN22-C duly executed by each director of the listed corporation;
 - (d) a letter in the form of Annexure PN22-D duly executed by each independent director of the listed corporation;
 - (e) a letter from the listed corporation's Principal Adviser confirming all approvals of relevant authorities have been obtained;
 - (f) a copy each of all letters of approval from the relevant authorities;

**Annexure PN22-A
Transfer application**

- (g) a cheque drawn to the order of Bursa Malaysia Securities Berhad for the listing fees together with a copy of the details of the computation of the amount of listing fees payable.
- (2) If any of the above documents are not filed because they are not applicable or available in any case, the listed corporation must submit a separate exhibit explaining why such documents are not applicable or available.

[End of Annexure]

Annexure PN22-B
Undertaking by a listed corporation for a transfer to the Main Market

ANNEXURE PN22-B

Undertaking by a listed corporation transferring from the ACE Market to the Main Market
(paragraph 4.1)

To:

Bursa Malaysia Securities Berhad
Exchange Square
Bukit Kewangan
50200 Kuala Lumpur

Compliance with Main Market Listing Requirements and Rules of Bursa Malaysia Securities Berhad
(**"Bursa Securities"**)

In consideration of Bursa Securities approving the application for transfer of
(**"Corporation"**) to the Main Market of Bursa Securities WE ACKNOWLEDGE that the Corporation shall remain on the Official List of Bursa Securities, and official quotation of any of the Corporation's securities shall continue only during the pleasure of Bursa Securities and WE UNDERTAKE AND AGREE to comply with Bursa Securities Main Market Listing Requirements and the Rules of Bursa Securities , including any amendment as may be made from time to time, insofar as the same shall apply to the Corporation.

**This Undertaking is deemed to have been made in Malaysia and the construction, validity and performance of this Undertaking are governed in all respects by the laws of Malaysia and WE irrevocably submit to the jurisdiction of the Malaysian Courts.

The above Undertaking has been signed by me as [title] of[name of Corporation] pursuant to authority granted to me by resolution of the board of directors of the Corporation on

Date:

Signature:

Name:

** Applicable to a foreign listed corporation only.

[End of Annexure]

Annexure PN22-C
Undertaking by a director for a transfer to the Main Market

ANNEXURE PN22-C

Undertaking by a director of a listed corporation transferring from the ACE Market to the Main Market

(paragraph 4.2(a))

To:

Bursa Malaysia Securities Berhad
Exchange Square
Bukit Kewangan
50200 Kuala Lumpur

Compliance with Main Market Listing Requirements

I,[name ~~and NRIC number~~ of director], am a director of.....
[name of the listed corporation ("**Corporation**") which has submitted an application to Bursa Malaysia Securities Berhad ("**Bursa Securities**") to be transferred to the Main Market of Bursa Securities ("**Main Market**").

In consideration of Bursa Securities approving the Corporation's application for transfer to the Main Market, I UNDERTAKE AND AGREE to comply with Bursa Securities Main Market Listing Requirements including any amendment as may be made from time to time, insofar as the same shall apply to me as a director of the Corporation.

**This Undertaking is deemed to have been made in Malaysia and the construction, validity and performance of this Undertaking are governed in all respects by the laws of Malaysia and I irrevocably submit to the jurisdiction of the Malaysian Courts.

Yours faithfully,

.....

Name:

NRIC No. (Old & New):

**Passport No. & Country of Issuance:

Designation:

Date:

** Applicable to a foreign director only.

[End of Annexure]

Annexure PN22-D
Confirmation by an independent director for transfer to the Main Market

ANNEXURE PN22-D

Letter of confirmation by an independent director of a listed corporation transferring from the ACE Market to the Main Market
(paragraph 4.2(b))

To:

Bursa Malaysia Securities Berhad
Exchange Square
Bukit Kewangan
50200 Kuala Lumpur

Confirmation of "independence" pursuant to Main Market Listing Requirements

I, [name ~~and NRIC number~~ of director], am a director of
[name of the listed corporation which has submitted an application to Bursa Securities to be transferred to the Main Market of Bursa Securities.

I CONFIRM AND DECLARE that I am an independent director as defined under paragraph 1.01 of Bursa Securities Main Market Listing Requirements.

**This Confirmation is deemed to have been made in Malaysia and the construction, validity and performance of this Confirmation are governed in all respects by the laws of Malaysia and I irrevocably submit to the jurisdiction of the Malaysian Courts.

Yours faithfully,

.....

Name:

NRIC No. (Old & New):

**Passport No. & Country of Issuance:

Designation:

Date:

** Applicable to a foreign independent director only.

[End of Annexure]

BURSA MALAYSIA SECURITIES BERHAD**PRACTICE NOTE 23****LISTING PROCEDURES FOR SPECIFIC APPLICANTS**

Details	Cross References
Effective date: 3 August 2009	Paragraphs 4.04, 4.09, 4.14 and 15.03

1.0 Introduction

1.1 This Practice Note sets out the following requirements in relation to an application for admission by a real estate investment trust under paragraph 4.04, an exchange-traded fund under paragraph 4.09, and a special purpose acquisition company under paragraph 4.14 of the Listing Requirements respectively:

- (a) the procedures for admission;
- (b) the initial listing application forms and supporting documents;
- (c) the undertakings and confirmation by a director of a SPAC, trustee, management company and director of a management company of a real estate investment trust and exchange-traded fund; and
- (d) other relevant requirements.

PART I LISTING APPLICATION BY REAL ESTATE INVESTMENT TRUST**2.0 Procedures relating to listing of real estate investment trust**

2.1 The procedures relating to admission set out in paragraph 2.0 of Practice Note 21 apply to the listing of a real estate investment trust.

3.0 Listing application form and supporting documents

3.1 A management company must file with the Exchange a listing application which consists of the following:

- (a) the application, in the form of Part A of Annexure PN23-A; and
- (b) the supporting documents specified in Part B of Annexure PN21-A (where applicable) and Part B of Annexure PN23-A.

4.0 Undertakings and confirmation

4.1 A trustee and management company must give the Exchange an undertaking in the form of Annexure PN23-B.

-
- 4.2 A management company must ensure that -
- (a) every director of the management company gives the Exchange an undertaking in the form of Annexure PN23-C; and
 - (b) every director who is or has been appointed as an independent director gives the Exchange a letter in the form of Annexure PN23-D.

5.0 Listing of issued and unissued units

- 5.1 A management company must comply with paragraph 6.0 of Practice Note 21 as if it were the applicant mentioned in that paragraph 6.0, with the necessary modifications.

PART II LISTING APPLICATION BY EXCHANGE-TRADED FUND

6.0 Procedures relating to listing of exchange-traded fund

- 6.1 The procedures relating to admission set out in paragraph 2.0 of Practice Note 21 apply to the listing of a real estate investment trust.

7.0 Listing application

- 7.1 A management company must file with the Exchange a listing application which consists of the following:
- (a) the application, in the form of Part A of Annexure PN23-E; and
 - (b) the supporting documents specified in Part B of Annexure PN21-A (where applicable) and Part B of Annexure PN23-E.
- 7.2 A management company must ensure that the application for listing referred to in paragraph 7.1 above covers all units approved for listing by the SC, including the unissued amount reserved for subsequent issuance.

8.0 Undertakings and confirmation

- 8.1 A trustee and management company must give the Exchange an undertaking in the form of Annexure PN23-F.
- 8.2 A management company must ensure that -
- (a) every director of the management company gives the Exchange an undertaking in the form of Annexure PN23-G; and
 - (b) every director who is or has been appointed as an independent director gives the Exchange a letter in the form of Annexure PN23-H.

9.0 Listing of issued and unissued securities

- 9.1 A management company must comply with paragraph 6.0 of Practice Note 21 as if it were the applicant mentioned in that paragraph 6.0, with the necessary modifications.

PART III LISTING APPLICATION BY SPECIAL PURPOSE ACQUISITION COMPANY**10.0 Procedure relating to admission of a special purpose acquisition company**

10.1 The procedures relating to admission set out in paragraph 2.0 of Practice Note 21 apply to the listing by a SPAC.

11.0 Listing application form and supporting documents

11.1 A SPAC must file with the Exchange a listing application which consists of the following:

- (a) the application, in the form of Part A of Annexure PN23-I; and
- (b) the supporting documents specified in Part B of Annexure PN23-I (where applicable).

12.0 Undertakings and confirmation

12.1 A SPAC must give the Exchange an undertaking in the form of Annexure PN21-B.

12.2 A SPAC must ensure that –

- (a) every director of the SPAC gives the Exchange an undertaking in the form of Annexure PN21-C; and
- (b) every director who is or has been appointed as an independent director gives the Exchange a letter in the form of Annexure PN21-D; and
- ~~(c) every member of the management team who is not a director of the SPAC gives the Exchange an undertaking in the form of Annexure PN23-J.~~

Annexure PN23-A
Initial listing application (real estate investment trust)

ANNEXURE PN23-A

Part A

Initial listing application in respect of a real estate investment trust
 (paragraph 3.1(a))

1.	Name of Trust Fund	
2.	Name of management company	
3.	Number of units applied for listing	
4.	<u>Currency denomination which the new units will be listed and quoted</u>	<p>(a) Ringgit Malaysia ("RM") <input type="checkbox"/></p> <p>(b) Others : (Please indicate)</p> <p>-----</p> <p><u>In the event the new units are listed and quoted in currencies other than RM, whether the approval of the Controller of Foreign Exchange has been obtained?</u></p> <p>_____ Yes <input type="checkbox"/></p> <p>_____ No <input type="checkbox"/></p>
45.	Proforma unit spread	[]% and [] public unit holders
56.	Tentative listing date (to specify)	
67.	3 top preferences <u>S</u>stock <u>S</u>hort <u>N</u>ame (limited to 7 characters)	<p>(a) Option 1:</p> <p>(b) Option 2:</p> <p>(c) Option 3:</p>
78.	Undertakings	<p>We undertake the following:</p> <p>(a) all notices of allotment will be issued and despatched to all successful applicants prior to the date of listing and quotation of the units;</p> <p>(b) all units will rank pari passu in all respects with each other;</p> <p>(c) all allotment information will be submitted to the Depository for the crediting of units into the respective securities holders' accounts;</p>

Annexure PN23-A
Initial listing application (real estate investment trust)

		<p>(d) the unit spread will be in compliance with paragraph 4.07 of Bursa Malaysia Securities Berhad (“Exchange”) Main Market Listing Requirements (“LR”);</p> <p>(e) a schedule of distribution showing compliance to the unit spread mentioned in item (d) above, as per Part B(1)(d) of Annexure PN21-A will be furnished to the Exchange on the first day of listing;</p> <p>(f) all conditions, including conditions imposed by the relevant authorities, if any, which are required to be met before the listing and quotation of the units, will be met;</p> <p>(g) there are no circumstances or facts which have the effect of preventing or prohibiting the issuance, listing and/or quotation of the units including any order, injunction or any other directive issued by any court of law;</p> <p>(h) to immediately inform the Exchange upon becoming aware, after submission of the listing application, that the applicant has failed to meet any of the above undertakings referred to in paragraphs (a) to (f) or of any circumstances or facts referred to in paragraph (g) above; and</p> <p>(i) to announce to the Exchange in accordance with paragraphs 8.1 and 8.2 of Practice Note 21.</p>
<p>_____ [Authorised signatory of the Principal Adviser] Name: Designation: Date:</p>		<p>_____ [Authorised signatory of the management company] Name: Designation: Date:</p>

Part B

Additional documents to be filed with a initial listing application in respect of a real estate investment trust

(paragraph 3.1(b))

- (1) A management company must file the following documents in support of a listing application for a real estate investment trust:
- (a) a copy of the trust deed registered with the relevant authorities together with the letter of compliance pursuant to paragraph 2.12 and a checklist showing compliance with Appendix 4A of the Listing Requirements;
 - (b) a copy of the memorandum and articles of association of the management company and all amendments to-date;
 - (c) a letter of undertaking in the form of Annexure PN23-B duly executed by the trustee and management company together with a certified true extract of the board of directors’ resolutions of the boards of the trustee and management company authorising the signatories;

Annexure PN23-A
Initial listing application (real estate investment trust)

- (d) a letter of undertaking in the form of Annexure 23-C duly executed by each director of the management company; and
 - (e) a letter in the form of Annexure 23-D duly executed by the independent director of the management company.
- (2) If any of the above documents are not filed because they are not applicable in any case, the management company must submit a separate exhibit explaining why such documents are not applicable.

[_End of Annexure-]

Annexure PN23-B
Undertaking by trustee/management company
(real estate investment trust)

ANNEXURE PN23-B

Undertaking by a trustee and management company of a real estate investment trust
(paragraph 4.1)

To:

Bursa Malaysia Securities Berhad
Exchange Square
Bukit Kewangan
50200 Kuala Lumpur.

Compliance with Main Market Listing Requirements and Rules of Bursa Malaysia Securities Berhad
("Bursa Securities")

In consideration of Bursa Securities granting the application for admission of [name of the real estate investment trust] ("**Trust**") to the Official List of Bursa Securities ("**Official List**") and for official quotation of the units described in our listing application, WE, [names of trustee and management company] ACKNOWLEDGE that the Trust shall remain on the Official List, and official quotation of any of the Trust's units shall continue only during the pleasure of Bursa Securities and WE UNDERTAKE AND AGREE to comply with Bursa Securities Main Market Listing Requirements and the Rules of Bursa Securities, including any amendment as may be made from time to time, insofar as the same shall apply to the Trust.

The above Undertaking has been signed by us as-

(i)[title] of[trustee] pursuant to the authority granted to me by resolution of the board of directors of the said trustee on

(ii)[title] of[management company] pursuant to authority granted to me by resolution of the board of directors of the said management company on

Date:
Trustee:
Signature:
Name:

Date:
Management company:
Signature:
Name:

[_End of Annexure]

Annexure PN23-C
Undertaking by a director of management company
(real estate investment trust)

ANNEXURE PN23-C

Undertaking by a director of a management company of a real estate investment trust
(paragraph 4.2(a))

To:

Bursa Malaysia Securities Berhad
Exchange Square
Bukit Kewangan
50200 Kuala Lumpur

Compliance with Main Market Listing Requirements

I, [name ~~and NRIC number~~ of director], am a director of[name of management company] ("**Company**") which #has submitted an application to Bursa Malaysia Securities Berhad ("**Bursa Securities**") for the real estate investment trust.....[name of the trust] ("**Trust**") to be admitted to the Official List of Bursa Securities ("**Official List**") / #is/are listed on the Official List of Bursa Securities.

In consideration of Bursa Securities #approving the Company's application for admission of the Trust to the Official List / allowing the continued listing of the Trust on the Official List, I UNDERTAKE AND AGREE to comply with Bursa Securities Main Market Listing Requirements including any amendment as may be made from time to time, insofar as the same shall apply to me as a director of the Company.

**This Undertaking is deemed to have been made in Malaysia and the construction, validity and performance of this Undertaking are governed in all respects by the laws of Malaysia and I irrevocably submit to the jurisdiction of the Malaysian Courts.

Yours faithfully,

.....

Name:

NRIC No. (Old & New):

**Passport No. & Country of Issuance:

Designation:

Date:

Delete as appropriate

** Applicable to a foreign director only.

[End of Annexure]

Annexure PN23-D
Confirmation by an independent director
(real estate investment trust)

ANNEXURE PN23-D

Letter of confirmation by an independent director of a management company of a real estate investment trust
(paragraph 4.2(b))

To:

Bursa Malaysia Securities Berhad
Exchange Square
Bukit Kewangan
50200 Kuala Lumpur

Confirmation of "independence" pursuant to Main Market Listing Requirements

I, [name ~~and NRIC number~~ of director], am a director of
[name of management company of real estate investment trust] which #has submitted an application to Bursa Malaysia Securities Berhad ("**Bursa Securities**") to be admitted to the Official List of Bursa Securities / is listed on the Official List of Bursa Securities.

I CONFIRM AND DECLARE that I am an independent member as defined in the Securities Commission's Guidelines on Real Estate Investment Trusts.

**This Confirmation is deemed to have been made in Malaysia and the construction, validity and performance of this Confirmation are governed in all respects by the laws of Malaysia and I irrevocably submit to the jurisdiction of the Malaysian Courts.

Yours faithfully,

.....

Name:

NRIC No. (Old & New):

**Passport No. & Country of Issuance:

Designation:

Date:

Delete as appropriate

** Applicable to a foreign independent director only.

[End of Annexure]

Annexure PN23-E
Initial listing application (exchange-traded fund)

ANNEXURE PN23-E

Part A

Initial listing application in respect of an exchange-traded fund
 (paragraph 7.1(a))

1.	Name of Fund	
2.	Name of management company	
3.	Number of units applied for listing	
4.	Tentative listing date (to specify)	
5.	3 top preferences Sstock Sshort Nname (limited to 7 characters)	(a) Option 1: (b) Option 2: (c) Option 3:
6.	Undertakings	We undertake the following: <ul style="list-style-type: none"> (a) all notices of allotment will be issued and despatched to all successful applicants prior to the date of listing and quotation of the units, or where it relates to new units issued after listing, upon creation of the new units, as the case may be; (b) all units issued will rank pari passu in all respects with each other, or where it relates to new units issued after listing, such units will rank pari passu in all respects with the existing units; (c) all allotment information will be submitted to the Depository for the crediting of units issued; (d) all conditions, including conditions imposed by the relevant authorities, if any, which are required to be met prior to the listing and quotation of the units have been met, or where it relates to new units issued after listing, such conditions will be met, as the case may be; (e) there are no circumstances or facts which have the effect of preventing or prohibiting the issuance, listing and/or quotation of the units, including any order, injunction or any other directive issued by any court of law; (f) in relation to the new units issued after listing, there will be no circumstances or facts which have the effect of preventing or prohibiting the issuance, listing and/or quotation of the units, including any order, injunction or any other directive issued by any court of law;

Annexure PN23-E
Initial listing application (exchange-traded fund)

		<p>(g) to immediately inform the Exchange upon becoming aware, after submission of the listing application, that the applicant has failed to meet any of the above undertakings referred to in paragraphs (a) to (d) or of any circumstances or facts referred to in paragraphs (e) and (f) above; and</p> <p>(h) to announce to the Exchange in accordance with paragraphs 8.1 and 8.2 of Practice Note 21.</p>
<p>_____ [Authorised signatory of the Principal Adviser] Name: Designation: Date:</p>		<p>_____ [Authorised signatory of the management company] Name: Designation: Date:</p>

Part B

Additional documents to be filed with a listing application in respect of an exchange-traded fund

(paragraph 7.1(b))

- (1) A management company must file the following documents in support of a listing application for an exchange-traded fund:
 - (a) a copy of the trust deed registered with the relevant authorities together with the letter of compliance pursuant to paragraph 2.12 and a checklist showing compliance with Appendix 4B of the Listing Requirements;
 - (b) a copy of the memorandum and articles of association of the management company and all amendments to-date;
 - (c) a letter of undertaking in the form of Annexure PN23-F duly executed by the trustee and management company together with a certified true extract of the board of directors' resolutions of the boards of the trustee and management company authorising the signatories;
 - (d) a letter of undertaking in the form of Annexure PN23-G duly executed by each director of the management company; and
 - (e) a letter in the form of Annexure PN23-H duly executed by each independent director of the management company.
- (2) If any of the above documents is not filed because it is not applicable in any case, the management company must submit a separate exhibit explaining why such documents are not applicable.

[End of Annexure]

Annexure PN23-F
Undertaking by trustee/management company
(exchange traded fund)

ANNEXURE PN23-F

Undertaking by a trustee and management company of an exchange-traded fund
(paragraph 8.1)

To:
Bursa Malaysia Securities Berhad
Exchange Square
Bukit Kewangan
50200 Kuala Lumpur.

Compliance with Main Market Listing Requirements and Rules of Bursa Malaysia Securities Berhad
("Bursa Securities")

In consideration of Bursa Securities granting the application for admission of [name of the exchange-traded fund] ("ETF") to the Official List of Bursa Securities ("Official List") and for official quotation of the units described in our listing application, WE, [names of trustee and management company] ACKNOWLEDGE that the ETF shall remain on the Official List, and official quotation of any of the ETF's units shall continue only during the pleasure of Bursa Securities and WE UNDERTAKE AND AGREE to comply with Bursa Securities Main Market Listing Requirements and the Rules of Bursa Securities, including any amendment as may be made from time to time, insofar as the same shall apply to the ETF.

**This Undertaking is deemed to have been made in Malaysia and the construction, validity and performance of this Undertaking are governed in all respects by the laws of Malaysia and WE irrevocably submit to the jurisdiction of the Malaysian Courts.

The above Undertaking has been signed by us as-

- (i)[title] of[trustee] pursuant to the authority granted to me by resolution of the board of directors of the said trustee on
- (ii)[title] of[management company] pursuant to authority granted to me by resolution of the board of directors of the said management company on

Date:
Trustee:
Signature:
Name:

Date:
Management company:
Signature:
Name:

** Applicable to a foreign trustee and management company only.

[End of Annexure]

Annexure PN23-G
Undertaking by a director of management company
(exchange traded fund)

ANNEXURE PN23-G

Undertaking by a director of a management company of an exchange-traded fund
(paragraph 8.2(a))

To:

Bursa Malaysia Securities Berhad
Exchange Square
Bukit Kewangan
50200 Kuala Lumpur

Compliance with Main Market Listing Requirements

I, [name ~~and NRIC number~~ of director], am a director of[name of management company] ("**Company**") which #has submitted an application to Bursa Malaysia Securities Berhad ("**Bursa Securities**") for the exchange-traded fund[name of the fund] ("**ETF**") to be admitted to the Official List of Bursa Securities ("**Official List**") / #is/are listed on the Official List of Bursa Securities .

In consideration of Bursa Securities #approving the Company's application for admission of the ETF to the Official List / allowing the continued listing of the ETF on the Official List, I UNDERTAKE AND AGREE to comply with Bursa Securities Main Market Listing Requirements including any amendment as may be made from time to time, insofar as the same shall apply to me as a director of the Company.

**This Undertaking is deemed to have been made in Malaysia and the construction, validity and performance of this Undertaking are governed in all respects by the laws of Malaysia and I irrevocably submit to the jurisdiction of the Malaysian Courts.

Yours faithfully,

.....

Name:

NRIC No. (Old & New):

**Passport No. & Country of Issuance:

Designation:

Date:

Delete as appropriate

** Applicable to a foreign director only.

[End of Annexure]

Annexure PN23-H
Confirmation by an independent director
(exchange traded fund)

ANNEXURE **PN23-H**

Letter of confirmation by an independent director of a management company of an exchange-traded fund

(paragraph 8.2(b))

To:

Bursa Malaysia Securities Berhad
Exchange Square
Bukit Kewangan
50200 Kuala Lumpur

Confirmation of "independence" pursuant to Main Market Listing Requirements

I, [name ~~and NRIC number~~ of director], am a director of [name of management company of exchange-traded fund] which #has submitted an application to Bursa Malaysia Securities Berhad ("**Bursa Securities**") to be admitted to the Official List of Bursa Securities / is listed on the Official List of Bursa Securities.

I CONFIRM AND DECLARE that I am an independent member in the Securities Commission's Exchange-Traded Funds Guidelines ~~on Exchange-Traded Funds~~.

**This Confirmation is deemed to have been made in Malaysia and the construction, validity and performance of this Confirmation are governed in all respects by the laws of Malaysia and I irrevocably submit to the jurisdiction of the Malaysian Courts.

Yours faithfully,

.....

Name:

NRIC No. (Old & New):

**Passport No. & Country of Issuance:

Designation:

Date:

Delete as appropriate

** Applicable to a foreign independent director only.

[End of Annexure]

ANNEXURE PN23-I

Part A

Initial listing application in respect of SPAC
(paragraph 11.1 (a))

Please tick wherever applicable. If not applicable, please indicate "N/A"
[You may tick more than one box, where applicable]

Deleted as appropriate

1.	Name of Company	
2.	Details of proposals which form part of the IPO	
	Number & types of securities applied for listing, par value & issue price (if any)	
3.	Proforma Public Shareholding Spread	<u>ORDINARY SHARE/ PREFERENCE SHARES</u> []% and [] public shareholders
4.	Tentative listing date (to specify)	
5.	Top 3 stock names (limited to 7 characters)	(a) Option 1: (b) Option 2: (c) Option 3:
6.	Currency denomination which the new securities will be listed and quoted	(a) (a) Ringgit Malaysia ("RM") <input type="checkbox"/> (b) (b) Others : (Please indicate) <input type="checkbox"/> ----- In the event the new securities are listed and quoted in currencies other than RM, whether the approval of the Controller of Foreign Exchange has been obtained ? _____ Yes <input type="checkbox"/>

Annexure PN23-I
Initial listing application (SPAC)

		<p>(k) to announce to the Exchange the relevant information in accordance with paragraphs 8.1 and 8.2 of Practice Note 21; and</p> <p>(l) to announce the latest quarterly results, where applicable, at least 2 market days before the date of listing.</p>
<p>[Authorised signatory of the Principal Adviser] Name: Designation: Date:</p>		<p>[Authorised signatory of the applicant] Name: Designation: Date:</p>

PART B

Documents to be filed with a listing application

(paragraphs 11.1(b))

- (1) An applicant must file the following documents in support of a listing application:
- (a) a copy each of the articles of association and all amendments to-date and one copy each of the certificate of incorporation, certificate of change of status and certificate of change of name, if any, together with a letter of compliance pursuant to paragraph 2.12 and a checklist showing compliance with the relevant provisions of Chapter 7;
 - (b) a copy of the draft prospectus submitted to the relevant authorities or the draft introductory document;
 - (c) a specimen copy of each denomination of certificates of the class to be listed. If transfer offices and registrars are maintained in more than one place, one specimen of each denomination of certificates used in each office (see Chapter 8 for form and content of certificates);
 - (d) a statement on the percentage of the total number of shares for which listing is sought which are held by the public, the number of public shareholders and a pro forma distribution of the shares in the following format:

<i>Particulars</i>	<i>No of Shares</i>	<i>No of shareholders</i>	<i>Percentage %</i>
<i>Issued and paid-up capital/ preference shares</i>			
<i>Less:</i>			
<i>Directors of the applicant and its subsidiaries</i>			
<i>and/or associated companies</i>			
<i>Substantial shareholders of</i>			

the applicant (except where such shareholder may be included as "public")

Associates of directors or substantial shareholders of the applicant

Shareholders holding less than 100 shares -----

Public shareholdings

- (e) a letter of undertaking in the form of Annexure PN21-B duly executed by the applicant together with a certified true extract of the applicant's board of directors' resolution authorising the signatory;
- (f) a letter of undertaking in the form of Annexure PN21-C duly executed by each director of the applicant;
- (g) a letter in the form of Annexure PN21-D duly executed by each independent director of the applicant;
- ~~(h) a letter in the form of Annexure PN23-J duly executed by each member of the management team who is not a director of the SPAC~~
- ~~(+)(h)~~ a letter from the applicant's Principal Adviser confirming all approvals of relevant authorities have been obtained;
- ~~(+)(i)~~ a copy each of all letters of approval from the relevant authorities;
- ~~(+)(j)~~ a proposal as to classification of the applicant in a specific sector in the prescribed form;
- ~~(+)(k)~~ a letter of notification issued by the applicant for the appointment of stabilizing manager that includes—
- (i) where the stabilizing manager is a Participating Organisation, the name, business address and contact person of the Participating Organisation, name of the Capital Markets Services Representative's License holder that will be conducting the stabilizing action;
 - (ii) where the stabilizing manager is not a Participating Organisation, the name and business address of the person appointed as the stabilizing manager and a contact person, the name of the Participating Organization and the Capital Markets Services Representative's License holder that has been appointed to conduct the stabilizing action;
 - (iii) where a stabilizing manager is appointed outside Malaysia, the name, address and contact person of the stabilizing manager appointed at that jurisdiction, the name, address and contact person of the Participating Organisation appointed in Malaysia to conduct the stabilizing action in Malaysia, along with the name of the Capital Markets Services

Representative's License holder that will be conducting the stabilizing action in Malaysia; or

- (iv) an undertaking to inform the Exchange of any subsequent change of the stabilizing manager, Capital Markets Services Representative's License holder or Participating Organisation, where applicable, immediately upon such change; and

~~(m)~~(l) a cheque drawn to the order of Bursa Malaysia Securities Berhad for the listing fees (see Schedule of Fees for computation of amount) together with a copy of the details of the computation of the amount of listing fees payable.

- (2) If any of the above documents are not filed because they are not applicable or available in any case, an applicant must submit a separate exhibit explaining why such documents are not applicable or available.

Annexure PN23-J
Undertaking by a member of management team (SPAC)

ANNEXURE PN23-J

Undertaking by a member of the management team of a SPAC who is not a director
 (paragraph 12.2(c))

To:

~~Bursa Malaysia Securities Berhad
 Exchange Square
 Bukit Kewangan
 50200 Kuala Lumpur.~~

~~Compliance with Main Market Listing Requirements and Rules of Bursa Malaysia Securities Berhad
 (“**Bursa Securities**”)~~

~~I,[name and NRIC number of management team member], am a member of
 the management team of[name(s) of special purpose acquisition company]
 (“**Corporation**”) which has submitted an application(s) to be admitted to the Official List of the Bursa
 Securities (“**Official List**”)~~

~~In consideration of Bursa Securities #approving the above application(s)/ allowing the continued
 listing of the #Corporation(s) on the Official List, I UNDERTAKE AND AGREE to comply with Bursa
 Securities Main Market Listing Requirements including any amendment as may be made from time to
 time, insofar as the same apply to me as a member of the management team of the #Corporation(s).~~

~~Yours faithfully,~~

~~.....~~

~~Name:~~

~~Designation:~~

~~Date:~~

~~# Delete as appropriate~~

[End of Annexure]

BURSA MALAYSIA SECURITIES BERHAD**PRACTICE NOTE 24****LISTING PROCEDURES FOR FOREIGN LISTING**

Details	Cross References
Effective date: 3 August 2009	Paragraphs 4A.06 and 4A.20

1.0 Introduction

1.1 This Practice Note sets out the following requirements in relation to a foreign corporation seeking a primary listing and a corporation seeking a secondary listing, on the Main Market under paragraphs 4A.06 and 4A.20 respectively:

- (a) the procedures for admission;
- (b) the listing and quotation application (where applicable) forms and supporting documents;
- (c) the undertakings and confirmation by an applicant and its directors; and
- (d) other relevant requirements.

PART I LISTING APPLICATION FOR A PRIMARY LISTING**2.0 Procedure relating to admission**

2.1 The procedures relating to admission set out in paragraph 2.0 of Practice Note 21 apply to an application for a primary listing on the Main Market.

3.0 Listing application form and supporting documents

3.1 A foreign corporation seeking a primary listing on the Main Market must file with the Exchange a listing application which consists of the following:

- (a) the application, in the form of Part A of Annexure PN21-A; and
- (b) the supporting documents specified in Part B of Annexure PN21-A and Part B of Annexure PN24-A.

4.0 Undertakings and confirmation

4.1 A foreign corporation seeking a primary listing on the Main Market must give the Exchange an undertaking in the form of Annexure PN24-B.

4.2 A foreign corporation seeking a primary listing on the Main Market must ensure that -

- (a) every one of its directors gives the Exchange an undertaking in the form of Annexure PN21-C; and
- (b) every director who is or has been appointed as an independent director gives the Exchange a letter in the form of Annexure PN21-D.

PART II LISTING APPLICATION FOR A SECONDARY LISTING

5.0 Procedures relating to admission

5.1 The following procedures apply to the admission of a corporation seeking a secondary listing on the Main Market, with the necessary modifications, as may be applicable:

- (a) ~~A~~an applicant submits an application to the relevant authorities at the place of incorporation and other stock exchange(s) ("**Relevant Authorities**") and the SC, if required under the applicable laws and rules~~;~~
- (b) ~~T~~he Relevant Authorities and the SC approve the listing~~;~~
- (c) ~~T~~he applicant files with the Exchange its articles of association together with a letter of compliance accompanied by a checklist showing compliance~~;~~
- (d) ~~T~~he applicant files the final copy of the prospectus with the Relevant Authorities~~;~~
- (e) ~~T~~he applicant -
 - (i) issues the prospectus or introductory document and the offer period opens, if the listing entails an offer of securities to the public;
 - (ii) advertises the prospectus or introductory document; and
 - (iii) provides the Exchange with such number of copies of the printed prospectus or introductory document as may be determined by the Exchange from time to time.
- (f) ~~T~~he applicant files with the Exchange a listing application together with supporting documents~~;~~
- (g) Exchange grants approval-in-principle for the admission of securities~~;~~
- (h) ~~I~~f the listing entails an offer of securities, the applicant announces the level of subscription and the basis of allocation~~;~~
- (i) ~~T~~he applicant issues securities and notices of allotment~~;~~
- (j) ~~T~~he applicant files with the Exchange a quotation application together with supporting documents~~; and~~
- (k) ~~S~~securities are admitted to the Official List and quoted on the Exchange 2 clear market days after receipt of the quotation application together with the requisite documents and confirmations and the same have been found to be complete in all respects.

6.0 Listing and quotation application

- 6.1 An applicant must file with the Exchange a listing application which consists of the following:
- (a) the application, in the form of Part A of Annexure PN24-A, duly signed by the corporation; and
 - (b) the supporting documents specified in Part B of Annexure PN24-A.
- 6.2 An applicant must also file with the Exchange a quotation application which is accompanied by -
- (a) the documents specified in Part C of Annexure PN24-A; and
 - (b) a confirmation that there are no circumstances or facts which have the effect of preventing or prohibiting the issuance, listing and/or quotation of the securities including any order, injunction or any other directive issued by any court of law.

7.0 Undertakings and confirmation

- 7.1 An applicant must give the Exchange an undertaking in the form of Annexure PN241-B.
- 7.2 An applicant must ensure that every one of its directors gives the Exchange an undertaking in the form of Annexure PN241-C.

8.0 Notification/Advertisement of securities prescribed by the Exchange to be deposited with the Depository

- 8.1 An applicant must comply with paragraph 5.0 of Practice Note 21 in relation to the prescription and depositing of the securities of an applicant, as if the applicant were the applicant mentioned in that paragraph 5.0.

9.0 Listing of issued and unissued securities

- 9.1 An applicant must apply for approval-in-principle to list only –
- (a) that part of the securities which have been issued; and
 - (b) securities to be issued in connection with the listing application.
- 9.2 If an additional unissued amount is reserved for subsequent issuance for a specific purpose, an applicant must apply for an approval-in-principle to add that amount to the Official List in the future for that specific purpose.
- 9.3 An applicant must not apply for an approval-in-principle for the listing of any security which is not reserved for subsequent issuance for a specific purpose.
- 9.4 An applicant must submit an application for quotation for such reserved amount for which approval-in-principle has been granted pursuant to subparagraph 9.1 above, upon actual issuance of such amount in accordance with the provisions of Practice Note 25.

10.0 Classification of an applicant of secondary listing

Paragraph 7.0 of Practice Note 21 applies to an applicant seeking for secondary listing on the Main Market, with the necessary modifications.

ANNEXURE PN24-A

PART A

Contents of a listing application for secondary listing

(paragraph 6.1(a))

Title page showing -

- (a) the name of the corporation and when and where it was incorporated;
- (b) the address of the principal registered office and the address of each office at which a share register is kept;
- (c) the class of securities proposed for listing and ~~their~~the par value ~~thereof~~; ~~and~~
- (d) the date of application, and formal request for listing, specifying amount, class and par value of the securities proposed for listing and whether the securities are fully paid; ~~and~~
- ~~(e) the currency which the new securities will be listed and quoted}. In the event the new securities are to be listed and quoted in currencies other than RM, a statement on whether the approval from the Controller of Foreign Exchange has been obtained~~

Part B

Documents to be filed with a listing application for primary and secondary listing

(paragraphs 3.1(b) and 6.1(b))

- (1) A corporation must file the following documents in support of a listing application:
 - (a) ~~A~~a confirmation that it is able to comply with the Listing Requirements, where applicable, insofar as such compliance does not contravene the laws of the place of incorporation; ~~;~~
 - (b) ~~W~~where the corporation is unable to comply with the Listing Requirements, a report from an independent legal adviser explaining why compliance with the relevant provisions of the Listing Requirements will contravene the laws of the place of incorporation; ~~;~~
 - (c) ~~I~~n addition, for a foreign corporation, a copy of the certificate of registration issued by the Registrar of Companies under Part XI Division 2 of the Companies Act 1965; ~~;~~
 - (d) ~~A~~a copy each of the articles of association and all amendments to-date including the amendments to incorporate the standards of corporate governance, shareholders and minority interest protection and regulation on take-over and mergers equivalent to those provided in Malaysia in cases where the laws of the place of incorporation do not have the requisite standards together with a comparison of such standards provided in the laws of the place of incorporation and those provided in Malaysia; ~~;~~
 - (e) ~~A~~a copy each of the certificate of incorporation, certificate of change of status and certificate of change of name, if any; ~~;~~
 - (f) ~~A~~a copy of the prospectus registered with the relevant authorities or the introductory document or where this is not available, one copy of the draft prospectus submitted to the relevant authorities or the draft introductory document; ~~;~~

Annexure PN24-A
Listing application for primary/secondary listing

-
- (g) **Aa** specimen copy of each denomination of certificates of the class to be listed. If transfer offices and registrars are maintained in more than one place, one specimen of each denomination of certificates used in each office~~:-~~
- (h) **Aa** letter of undertaking in the form of Annexure PN241-B duly executed by the corporation together with a certified true extract of the corporation's board of directors' resolution authorizing the signatory~~:-~~
- (i) **Aa** letter of undertaking in the form of Annexure PN241-C duly executed by each director of the corporation~~:-~~
- ~~(j) a letter in the form of Annexure PN21-D duly executed by each independent director of the applicant, where applicable;~~
- ~~(k) **Aa** letter from the corporation's Principal Adviser confirming all approvals of relevant authorities have been obtained~~:-~~~~
- ~~(l) **Aa** copy each of all letters of approval from the relevant authorities; and-~~
- ~~(m) **Aa** proposal as to classification of the corporation in a specific sector in the prescribed form.~~
- (2) If any of the above documents are not filed because they are not applicable or available in any case, the corporation must submit a separate exhibit explaining why such documents are not applicable or available.

Part C**Documents to be filed with a quotation application**

(paragraph 6.2(a))

~~A corporation must file the following documents in support of a quotation application:~~

- (1) A copy of the latest return of allotment filed with the Registrar of Companies or in relation to a foreign corporation, a copy of a document showing its latest issued and paid-up capital filed with the relevant authority pursuant to the laws of the place of incorporation or in the event no such document is required to be filed pursuant to the relevant laws, a confirmation from the foreign corporation as to its latest issued and paid-up capital.
- (2) An undertaking that all notices of allotment will be issued and dispatched to all successful applicants before the date of listing and quotation of the securities.
- (3) A confirmation from the Depository of the receipt of the allotment information for crediting of the securities.
- (4) A cheque drawn to the order of Bursa Malaysia Securities Berhad for the listing fees (see Schedule of Fees for computation of amount) together with a copy of the details of the computation of the amount of listing fees payable.
- (5) Where a moratorium is imposed on the sale of securities, the following information on the moratorium:
- (a) the names of securities holders;
- (b) the number of securities;

**Annexure PN24-A
Listing application for primary/secondary listing**

- (c) the date (s) of expiry of the moratorium; and
- (d) a confirmation that the above information has been submitted to the Depository.
- (6) A confirmation from the ~~-~~Principal Adviser that all conditions including conditions imposed by the relevant authorities, if any, which are required to be met before the listing and quotation of the securities have been met.
- (7) Such applicable documents set out in Part B of Annexure PN24-A which were not submitted.
- (8) A confirmation from the Principal Adviser that there are no circumstances or facts which have the effect of preventing or prohibiting the issuance, listing and/or quotation of the corporation's securities, including any order, injunction or any other directive issued by any court of law.
- (9) A confirmation from the ~~-~~Principal Adviser that the new securities rank pari passu in all respects with each other.

[End of Annexure]

Annexure PN24-B
Undertaking by an applicant/foreign corporation for primary listing

ANNEXURE PN24-B

Undertaking by an applicant or foreign corporation in relation to primary listing
(paragraphs 4.1 and 7.1)

To:

Bursa Malaysia Securities Berhad
Exchange Square
Bukit Kewangan
50200 Kuala Lumpur

Compliance with Main Market Listing Requirements and Rules of Bursa Malaysia Securities Berhad
(**"Bursa Securities"**)

In consideration of Bursa Securities approving the application for admission of (**"Corporation"**) to the Official List of Bursa Securities (**"Official List"**) and for official quotation of the securities described in the Corporation's listing application, WE ACKNOWLEDGE that the Corporation shall remain on the Official List, and official quotation of any of the Corporation's securities shall continue only during the pleasure of Bursa Securities and WE UNDERTAKE AND AGREE to comply with Bursa Securities Main Market Listing Requirements and the Rules of Bursa Securities including any amendment as may be made from time to time, insofar as the same shall apply to the Corporation.

This Undertaking is deemed to have been made in Malaysia and the construction, validity and performance of this Undertaking are governed in all respects by the laws of Malaysia and WE irrevocably submit to the jurisdiction of the Malaysian Courts.

The above Undertaking has been signed by me as [title] of [name of the Corporation] pursuant to authority granted to me by resolution of the board of directors of the Corporation on

Date:

Signature:

Name:

[End of Annexure]

Annexure PN24-C
Undertaking by a director of an applicant/listed corporation

~~ANNEXURE PN24-C~~

Undertaking by a director of an applicant/a listed corporation
 (paragraph 7.2; paragraph 4A.30 of the Listing Requirements)

To:

Bursa Malaysia Securities Berhad
 Exchange Square
 Bukit Kewangan
 50200 Kuala Lumpur

Compliance with Main Market Listing Requirements

~~I, [name and NRIC number of director], am a director of
 [name (s) of applicant/listed corporations ("the Corporation(s)"] which
 #has/have submitted an application to Bursa Malaysia Securities Berhad ("**Bursa Securities**") to be
 admitted to the Official List of Bursa Securities ("**Official List**") / #is/are listed on the Official List of the
 Bursa Securities.~~

~~In consideration of Bursa Securities #approving the Corporation(s)'s application for admission to the
 Official List / allowing the continued listing of the Corporation(s) on the Official List, I UNDERTAKE
 AND AGREE to comply with Bursa Securities Main Market Listing Requirements including any
 amendment as may be made from time to time, insofar as the same applies to me as a director of the
 Corporation(s).~~

Yours faithfully,

.....
 Name:
 Designation:
 Date:

~~# Delete as appropriate~~

[End of Annexure]

BURSA MALAYSIA SECURITIES BERHAD

PRACTICE NOTE 25

LISTING PROCEDURES FOR NEW ISSUE OF SECURITIES BY CORPORATIONS WITH SECONDARY LISTING

Details	Cross References
Effective date: 3 August 2009	Paragraph 4A.245

1.0 Introduction

1.1 This Practice Note sets out the following requirements in relation to a listing application by a corporation with a secondary listing on the Main Market under paragraph 4A.245 (i.e. for listing of a new issue of securities):

- (a) the procedures for new issue of securities; and
- (b) the listing and quotation application forms and supporting documents.

2.0 Procedures relating to listing of a new issue of securities

2.1 The following procedures apply to the listing of a new issue of securities by a corporation with secondary listing on the Main Market, with the necessary modifications, as may be applicable:

- (a) ~~Li~~isted corporation immediately announces the new issue of securities to the Exchange upon the approval of its board of directors~~;~~
- (b) ~~Li~~isted corporation submits an application to the following parties if required under the applicable laws and rules –
 - (i) relevant authorities at the place of incorporation; and
 - (ii) the other stock exchange where the new issue of securities are admitted and quoted (“**Stock Exchange**”),
 (i) and (ii) above referred to collectively in this Practice Note as “**Relevant Authorities**”~~;~~
- (c) ~~T~~he Relevant Authorities approve the issuance and listing of the securities~~;~~
- (d) ~~Li~~isted corporation files with the Exchange a listing application for the new issue of securities together with supporting documents~~;~~
- (e) Exchange grants approval-in-principle for the listing of the new issue of securities~~;~~
- (f) ~~Li~~isted corporation obtains shareholder approval, if required, under the applicable laws and rules~~;~~

Practice Note 25
Listing Procedures for New Issue of Securities
By Corporation with Secondary Listing

- (g) ~~L~~isted corporation fixes relevant books closing and entitlement dates, where applicable, and immediately announces such dates to the Exchange;
 - (h) ~~L~~isted corporation issues and allots the securities;
 - (i) ~~L~~isted corporation files with the Exchange a quotation application together with supporting documents at least 2 market days before the securities are admitted and quoted on the Stock Exchange; ~~and~~
 - (j) ~~S~~ecurities are admitted to the Official List and quoted on the Exchange at the same time as they are admitted and quoted on the Stock Exchange if the quotation application together with the supporting documents are found to be complete in all respects.
- 2.2 If the listed corporation fails to make an application to the Relevant Authorities and the Exchange by the date specified in the announcement under paragraph 2.1 above, it must immediately announce to the Exchange the fact of such failure, its reasons and when it expects to make the application.

3.0 Listing and quotation application

- 3.1 A corporation with a secondary listing on the Main Market must file with the Exchange a listing application for a new issue of securities which consists of the following:
- (a) the application, in the form of Part A of Annexure PN25-A, duly signed by the listed corporation;
 - (b) the supporting documents specified in Part B of Annexure PN25-A; and
 - (c) the proposed admission and quotation date of the new securities on the Stock Exchange.
- 3.2 A listed corporation must also file with the Exchange a quotation application for a new issue of securities which is accompanied by -
- (a) a confirmation of the admission and quotation date of the new securities on the Stock Exchange;
 - (b) the documents specified in Part C of Annexure PN25-A;
 - (c) such applicable documents set out in paragraph 3.1 above which were not submitted; and
 - (d) other documents as may be specified in the approval-in-principle granted by the Exchange.

ANNEXURE PN25-A

Part A

Contents of a listing application for a new issue of securities

(paragraph 3.1(a))

- (1) Title Page showing -
 - (a) the name of the corporation with a secondary listing on the Main Market;
 - (b) the full title or designation of the securities proposed for listing;
 - (c) the date of application and formal request for listing, specifying the amount, par value (if any) and title of the securities proposed for listing, and whether the securities are fully paid;
 - (d) the purpose of issuance; and
 - (e) the currency which the new issue of securities will be listed and quoted. In the event the new issue of securities are to be listed and quoted in currencies other than RM, a statement on whether the approval from the Controller of Foreign Exchange has been obtained.
- (2) A table showing the class, ranking and number securities proposed for listing.

Part B

Documents to be filed with a listing application for a new issue of securities

(paragraph 3.1(b))

- (1) A corporation with a secondary listing on the Main Market must file the following documents in support of a listing application for a new issue of securities:
 - (a) Aa copy of the circular, prospectus or abridged prospectus which is registered with the relevant authorities;
 - (b) Aa certified true copy of the relevant resolution passed by securities holders in general meeting;
 - (c) Aa letter from the corporation's ~~Principal~~ Adviser confirming all approvals of relevant authorities have been obtained;
 - (d) Aa copy each of all letters of approval from the relevant authorities; and
 - (e) Aa cheque drawn to the order of Bursa Malaysia Securities Berhad for the processing fee (see the Schedule of Fees for the computation of the amount), where applicable, together with a copy of the details of the computation of the amount of listing fees payable.
- (2) If any of the above documents are not filed because they are not applicable or available in any case, the corporation must submit a separate exhibit explaining why such documents are not applicable or available.

Part C**Documents to be filed with a quotation application of a new issue of securities**
(paragraph 3.2(b))

A corporation with a secondary listing on the Main Market must file the following documents in support of a quotation application of a new issue of securities:

- (a) **Aa** confirmation from the corporation as to its latest issued and paid-up capital;
- (b) **Aa** confirmation that all notices of allotment have been issued and despatched to the entitled holders;
- (c) **Aa** confirmation from the corporation that the Depository is ready to credit the new securities to the accounts of the entitled holders, after receiving the allotment information for crediting of the new securities;
- (d) **Aa** cheque drawn to the order of Bursa Malaysia Securities Berhad for the listing fees (see Schedule of Fees for computation of amount) together with a copy of the details of the computation of the amount of listing fees payable;
- (e) **Aa** confirmation from the -Principal Adviser of whether the new issue of securities will be listed and quoted as the existing securities of the same class or will be separately quoted on the listing date. If the new issue of securities will be separately quoted on the listing date, to specify the entitlement that the holders of the new issue of securities will not be entitled to;
- (f) **Aa** confirmation from the Principal Adviser that all conditions, including conditions imposed by the relevant authorities, if any, which are required to be met before the listing and quotation of the securities have been met;
- (g) **Aa** confirmation from the Principal Adviser that there are no circumstances or facts which have the effect of preventing or prohibiting the issuance, listing and/or quotation of the securities, including any order, injunction or any other directive issued by any court of law; and
- (h) **Ss** such other documents which are not/have not been submitted pursuant to Part B of Annexure PN25-A.

[End of Annexure]

BURSA MALAYSIA SECURITIES BERHAD**PRACTICE NOTE 26****LISTING PROCEDURES UNDER AN EXEMPT REGIME**

Details		Cross References
Effective date:	3 August 2009	Paragraph 4B.03

1.0 Introduction

1.1 This Practice Note sets out the following requirements in relation to an application for listing of sukuk and debt securities under an Exempt Regime under Chapter 4B:

- (a) the procedures for admission;
- (b) the initial listing application form and supporting documents;
- (c) the undertakings and confirmation by an issuer; and
- (d) other relevant requirements.

2.0 Procedures relating to admission

2.1 The following procedures apply to the listing of sukuk or debt securities on the Exchange under an Exempt Regime, with the necessary modifications, as may be applicable:

- (a) issuer submits an application to the SC for the issue or offer of the sukuk or debt securities in Malaysia, where applicable;
- (b) SC approves the issue or offer, where applicable;
- (c) issuer files with the Exchange a listing application together with supporting documents;
- (d) Exchange grants approval for the listing of sukuk or debt securities;
- (e) where applicable, the issuer -
 - (i) issues the Information Memorandum/Offering Circular or such other document as may be acceptable under paragraph 4B.04(2) of the Listing Requirements (collectively referred to in this paragraph as "**Said Documents**");
 - (ii) provides the Exchange with 2 copies of the Said Documents as may be determined by the Exchange from time to time; and
 - (iii) announces the information set out in paragraph 5.0 below to the Exchange; and

- (f) Sukuk or debt securities are listed on the Official List of the Exchange.

3.0 Listing application form and supporting documents

3.1 An issuer must file with the Exchange a listing application which consists of the following:

- (a) the application, in the form of Part A of Annexure PN26-A; and
- (b) the supporting documents specified in Part B of Annexure PN26-A.

4.0 Undertakings and confirmation

4.1 An issuer must give the Exchange an undertaking in the form of Annexure PN26-B.

5.0 Announcements to the Exchange

5.1 An issuer must announce the following information before issuance of sukuk or debt securities for listing:

- (a) the issuer's name;
- (b) the programme/instrument name and type;
- (c) a brief description of the programme/instrument (e.g. coupon or profit rate);
- (d) the actual date of listing and issue date;
- (e) the programme/issue size;
- (f) the stock short name, stock code, ISIN code, where applicable; and
- (g) the initial rating of the programme/instruments and prevailing rating of the programme, if applicable.

5.2 An issuer must comply with paragraph 5.1 above in respect of each subsequent issuance of sukuk or debt securities for listing under a programme, where applicable.

Annexure PN26-A
Initial Listing Application for listing under an Exempt Regime

ANNEXURE PN26-A

PART A

Initial Listing application
(paragraph 3.1(a))

Please tick wherever applicable. If not applicable, please indicate "N/A"
[You may tick more than one box, where applicable]

1.	Name of Issuer	
2.	Types of Listing	2.1 Primary Listing <input type="checkbox"/> 2.2 Secondary Listing <input type="checkbox"/>
	Description of the instrument	
3.	Currency denomination under which the new securities will be listed	(a) Ringgit Malaysia ("RM") <input type="checkbox"/> (b) Others : (Please indicate) ----- In the event the new securities are listed in currencies other than RM, whether the approval of the Controller of Foreign Exchange has been obtained? _____ Yes <input type="checkbox"/> _____ No <input type="checkbox"/>
34.	Tentative listing date (to specify)	
45.	Undertakings	We undertake the following: (a) all relevant approvals which are required for the issuance and listing of the securities, if any, will be met; (b) all conditions, including conditions imposed by the relevant authorities, if any, which are required to be met before the listing of the securities will be met; (c) there are no circumstances or facts which have the effect of preventing or prohibiting the issuance and/or listing of the securities including any order, injunction or any other directive issued by any court of law;

**Annexure PN26-A
Initial Listing Application for listing under an Exempt Regime**

		<p>(d) to immediately inform the Exchange upon becoming aware, after submission of the listing application, that the issuer has failed to meet any of the above undertakings referred to in paragraphs (a) to (b) or of any circumstances under (c) above; and</p> <p>(e) to make the relevant announcements in accordance with paragraph 5.0 of Practice Note 26.</p>
<p>_____ [Authorised signatory of the adviser] Name: Designation: Date:</p>		<p>_____ [Authorised signatory of the issuer] Name: Designation: Date:</p>

Annexure PN26-A
Initial Listing Application for listing under an Exempt Regime

PART B**Documents to be filed with a listing application**

(paragraph 3.1(b))

- (1) An issuer must file the following documents in support of a listing application:
- (a) ~~Aa~~ copy each of the constitution of the issuer, the certificate of incorporation, certificate of change of status and certificate of change of name, if any~~;~~
 - (b) ~~Aa~~ copy of the Information Memorandum/Offering Circular or such other documents which are acceptable under paragraph 4B.04(2) of the Listing Requirements~~;~~
 - (c) ~~Aa~~ copy of the Trust Deed, facility agreement or other document securing or constituting the sukuk or debt securities~~;~~
 - (d) in case of secondary listing, the most recent Information Memorandum/Offering Circular filed with the issuer's primary exchange~~;~~
 - (e) a letter of undertaking in the form of Annexure PN26-B duly executed by the issuer together with a certified true extract of the issuer's board of directors' resolution authorising the signatory~~;~~
 - (f) ~~Aa~~ copy each of all letters of approval relating to the issue, offer and listing of the sukuk or debt securities from the relevant authorities, where applicable, and a letter from the issuer's adviser confirming all necessary approvals have been obtained~~;~~
 - (g) ~~Ff~~or sukuk issues or programmes, a certification or endorsement from the issuer's Shariah advisor that the issue or programme is Shariah-compliant~~;~~
 - (h) ~~Aa~~ copy of any temporary document of title and any definitive document of title in respect of the sukuk or debt securities~~;~~
 - (i) ~~Ii~~n the case of a foreign issuer, the names and addresses of its representatives, with whom the Exchange may liaise in respect of future correspondence regarding the sukuk or debt securities~~;~~
 - (j) ~~Aa~~ cheque drawn to the order of Bursa Malaysia Securities Berhad for the listing fees~~; and-~~
 - (k) ~~Aa~~ny other documents which may be required by the Exchange for the processing of the issuer's listing application.
- (2) If any of the above documents are not filed because they are not applicable or available in any case, an issuer must submit a separate exhibit explaining why such documents are not applicable or available.

[End of Annexure]

Annexure PN26-B
Undertaking by issuer for listing under an Exempt Regime

ANNEXURE PN26-B

Undertaking by an issuer for the listing of sukuk or debt securities
(paragraph 4.0)

To:

Bursa Malaysia Securities Berhad
Exchange Square
Bukit Kewangan
50200 Kuala Lumpur

Compliance with Main Market Listing Requirements

In consideration of Bursa Malaysia Securities Berhad (“**Bursa Securities**”) approving our application for admission of the sukuk or debt securities to the Official List of Bursa Securities (“**Official List**”) described in our listing application WE ACKNOWLEDGE that the sukuk or debt securities shall remain on the Official List only during the pleasure of Bursa Securities and WE UNDERTAKE AND AGREE to comply with Bursa Securities Main Market Listing Requirements, including any amendments as may be made from time to time, insofar as the same apply to us.

This Undertaking shall be deemed to have been made in Malaysia and the construction, validity and performance of this Undertaking shall be governed in all respects by the laws of Malaysia and WE irrevocably submit to the jurisdiction of the Malaysian Courts.

**This Undertaking is deemed to have been made in Malaysia and the construction, validity and performance of this Undertaking are governed in all respects by the laws of Malaysia and WE irrevocably submit to the jurisdiction of the Malaysian Courts.

The above Undertaking has been signed by me as [title] of [Issuer] pursuant to the authority granted to me by resolution of the board of directors of the issuer on

Date:

Signature:

Name:

** Applicable to a foreign issuer only.

[End of Annexure]

BURSA MALAYSIA SECURITIES BERHAD

PRACTICE NOTE 27

LISTING PROCEDURES FOR STRUCTURED WARRANTS

Details		Cross References
Effective date:	8 May 2009	Paragraphs 5.09 and 5.30
Revision date:	3 August 2009	

1.0 Introduction

1.1 This Practice Note sets out the following requirements in relation to an application for listing of structured warrants under paragraph 5.09 (PART I) and Further Issue under paragraph 5.30 of the Listing Requirements (PART II):

- (a) the procedures for listing of structured warrants and Further Issue;
- (b) the listing application form and supporting documents; and
- (c) other relevant requirements.

PART I LISTING OF STRUCTURED WARRANTS**2.0 Procedures relating to listing of ~~structured warrants where~~ a single issue of structured warrants ~~is sought~~**

2.1 The following procedures apply to the listing of ~~structured warrants on the Official List where~~ a single issue of structured warrants ~~is sought~~, with the necessary modifications, as may be applicable:

~~2.1 The following procedures apply to the listing of structured warrants on the Official List, with the necessary modifications, as may be applicable:~~

- (a) ~~the~~ issuer submits concurrently –
 - (i) a registrable prospectus to the SC; and
 - (ii) an application for the listing and quotation of structured warrant to the Exchange together with the supporting documents;
- (b) SC registers the prospectus;
- (c) Exchange grants approval for the listing and quotation of the structured warrants;
- (d) ~~the~~ issuer files the final copy of prospectus with the relevant authorities;
- (e) ~~the~~ issuer -

Practice Note 27
Listing Procedures For Structured Warrants

- (i) issues the prospectus and the offer period opens;
- (ii) advertises the prospectus;
- (iii) provides the Exchange with such number of copies of the printed prospectus as may be determined by the Exchange from time to time; and
- (iv) announces the information prescribed in accordance with paragraph 6.1 below to the Exchange;
- (f) Issuer issues the structured warrants and notices of allotment;
- (g) Issuer announces the information prescribed in accordance with paragraph 6.2 below to the Exchange; and
- (h) Structured warrants are admitted to the Official List and quoted on the Exchange.

3.0 Procedures relating to listing of ~~structured warrants where a~~ multiple issuance of structured warrants ~~is sought~~

3.1 The following procedures apply to the listing of ~~structured warrants on the Official List where a~~ multiple issuance of structured warrants ~~is sought~~, with the necessary modifications, as may be applicable:

- (a) Issuer submits a registrable base prospectus to the SC;
- (b) SC registers the base prospectus.
- (c) Issuer files the final copy of the base prospectus, with the relevant authorities;
- (d) Issuer -
 - (i) issues the base prospectus;
 - (ii) advertises the base prospectus, if applicable; and
 - (iii) provides the Exchange with such number of copies of the printed base prospectus as may be determined by the Exchange from time to time;
- (e) Issuer submits an application for the listing and quotation of structured warrants to the Exchange together with supporting documents;
- (f) Exchange grants approval for the listing and quotation of the structured warrants;
- (g) Issuer submits a registrable term sheet to the SC;
- (h) SC registers the term sheet;
- (i) Issuer files the final copy of the term sheet with the relevant authorities;
- (j) Issuer -
 - (i) issues the term sheet and the offer period opens (where applicable);
 - (ii) advertises the term sheet;

Practice Note 27
Listing Procedures For Structured Warrants

- (iii) provides the Exchange with such number of copies of the printed term sheet as may be determined by the Exchange from time to time; and
- (iv) announces the information prescribed in accordance with paragraph 6.1 below to the Exchange.
- (k) ~~Issuer~~ issues the structured warrants and notices of allotment, where applicable; ~~and~~
- (l) ~~Issuer~~ announces the information prescribed in accordance with paragraph 6.2 below to the Exchange.

4.0 Listing application form and supporting documents

4.1 An issuer must file with the exchange a listing application which consists of the following:

- (a) the application, in the form of Part A of Annexure PN27-A;
- (b) the supporting documents specified in Part B of Annexure PN27-A; and
- (a) such other documents as may be specified by the Exchange.

5.0 Undertakings and confirmation

5.1 An issuer must give the Exchange an undertaking in the form of Annexure PN27-C.

5.2 An issuer must ensure that every director of the issuer gives the Exchange an undertaking in the form of Annexure PN27-D.

6.0 Announcements to the Exchange

6.1 Upon the issuance of the prospectus/term sheets, an issuer must announce the following information to the Exchange. The issuer must attach a copy of the final terms of the structured warrants with the announcement:-

- (a) the opening and closing date of the offer period, if applicable;
- (b) the balloting date, if applicable;
- (c) the allotment date of the structured warrants (if applicable); and
- (d) the tentative listing date.

6.2 Upon receipt of confirmation from the Depository that the structured warrants are ready to be credited into the respective securities accounts, an issuer must immediately announce the following information to the Exchange:

- (a) actual date of listing;
- (b) issue size;
- (c) stock short name, stock code, ISIN code;
- (d) sector and board under which the securities will be listed;

Practice Note 27
Listing Procedures For Structured Warrants

- (e) terms of the structured warrants; and
 - (f) such other information as may be prescribed by the Exchange from time to time by way of an electronic template provided by the Exchange.
- 6.3 The issuer must immediately announce any subsequent amendments (including any amendments to the profile of the structured warrants arising from adjustments) after the initial announcement in paragraphs 6.1 and 6.2 above.

PART II FURTHER ISSUE

7.0 Procedures relating to Further issue

- 7.1 The following procedures apply to the listing of a Further Issue, with the necessary modifications, as may be applicable:
- (a) Issuer announces the following information to the Exchange as regards its proposal to make a Further Issue:
 - (i) the number of units to be issued;
 - (ii) a statement that the Further Issue forms a single series with the Existing Issue;
 - (iii) the tentative listing date; and
 - (iv) the approvals required for the Further Issue;
 - (b) Issuer submits an application for the listing and quotation of the Further Issue to the Exchange together with the relevant supporting documents;
 - (c) Exchange grants approval for the listing and quotation of additional structured warrants;
 - (d) Issuer submits a registrable term sheet (for Further Issue) to the SC;
 - (e) SC registers the term sheet.
 - (f) Issuer files the final copy of the term sheet with the relevant authorities, if applicable;
 - (g) Issuer -
 - (i) issues the term sheet, if applicable; and
 - (ii) provides the Exchange with such number of copies of the printed term sheet as may be determined by the Exchange from time to time, if applicable;
 - (h) Issuer issues the structured warrants;
 - (i) Upon receipt of confirmation from the Depository that the additional structured warrants are ready to be credited into the respective securities accounts, the issuer immediately announces the same to the Exchange. The issuer must include the following information in the announcement:
 - (i) the actual date of listing;
 - (ii) the number of units to be issued pursuant to the Further Issue;

Practice Note 27
Listing Procedures For Structured Warrants

- (iii) the enlarged number of the structured warrants; and
- (iv) such other information as may be prescribed by the Exchange from time to time by way of an electronic template provided by the Exchange; ~~and-~~
- (j) ~~A~~additional structured warrants are admitted to the Official List and quoted on the Exchange.

8.0 Listing application form and supporting documents for Further Issue

8.1 An issuer must file with the exchange a listing application which consists of the following:

- (a) the application for a Further Issue, in the form of Part A of Annexure PN27-B;
- (b) the supporting documents specified in Part B of Annexure PN27-B; and
- (c) such other documents as may be specified by the Exchange.

ANNEXURE PN27-A

Part A

Listing application for structured warrants
(paragraph 4.1(a))

Please tick wherever applicable. If not applicable, to indicate "N/A"
You may tick more than one box, where applicable]

1.	Name of h issuer <u>("Issuer")</u>	
2.	Amount and description of each S structured W warrants ("SW") applied for listing	
3.	Top preferences S stock S short N name for first-time foreign underlying (limited to 7 characters)	(a) Option 1: (b) Option 2: (c) Option 3:
4.	<u>Currency denomination which the SW will be listed and quoted</u>	(a) Ringgit Malaysia ("RM") <input type="checkbox"/> (b) Others : (Please indicate) ----- <u>In the event the SWs are listed and quoted in currencies other than RM, whether the approval of the Controller of Foreign Exchange has been obtained-?</u> _____ Yes <input type="checkbox"/> _____ No <input type="checkbox"/>
45.	Tentative listing date (to specify)	
56.	Proforma <u>Spreadnumber of SW holders</u>	Issuer intends to provide liquidity via market making Yes <input type="checkbox"/> No <input type="checkbox"/> Number of holders: _____

Annexure PN27-A
Listing application for structured warrants

		<p>The number of warrant holders will be in compliance with paragraph 5.11(1) of Bursa Malaysia Securities Berhad Main Market Listing Requirements ("LR")</p> <p align="right">Yes <input type="checkbox"/></p> <p align="right">No <input type="checkbox"/></p>
67.	Undertakings	<p>We undertake the following:</p> <ul style="list-style-type: none"> (a) the relevant paragraphs in Parts C, D, E, G, H and J of Chapter 5 of the LR will be complied with prior to the listing and quotation of the structured warrants; (b) all notices of allotment will be issued and despatched to all holders prior to the date of listing and quotation of the structured warrants, where applicable; (c) all allotment information of the structured warrants will be submitted to the Depository for the crediting of the structured warrants into the respective securities holders accounts; (d) a cheque drawn to the order of "Bursa Malaysia Securities Berhad" being the listing fees together with a copy of the details of the computation of the amount of listing fees payable will be submitted to the Exchange on the first day of listing of the structured warrants; (e) all conditions, including conditions imposed by the relevant authorities, if any, which are required to be met prior to the listing and quotation of the structured warrants will be met; (f) to comply with all relevant paragraphs in Chapter 5 of the LR and all other applicable laws relating to the issue, sale or offer of structured warrants; (g) there are no circumstances or facts which have the effect of preventing or prohibiting the issuance, listing and/or quotation of the structured warrants, including any order, injunction or any other directive issued by any court of law; (h) to immediately inform the Exchange upon becoming aware, after submission of the listing application, that the applicant has failed to meet any of the above undertakings referred to in paragraphs (a) to (f) or of any circumstances or facts referred to in paragraph (g) above; (i) to make the relevant announcements in accordance with paragraph 6.0 of Practice Note 27; (j) to furnish the Exchange on the first day of listing, a confirmation that the relevant paragraphs in Parts C, D, E, G, H and J of Chapter 5 of the LR has been complied with; (k) to furnish the Exchange on the first day of listing, a letter from the eligible broker or if the issuer is an eligible broker or licensed institution approved by Bank Negara Malaysia submitting the application on its own behalf, a letter from the

**Annexure PN27-A
Listing application for structured warrants**

		<p>issuer, confirming all approvals of relevant authorities have been obtained (if applicable);</p> <p>(l) to furnish the Exchange on the first day of listing, a copy each of all letters of approval from the relevant authorities which have not been filed with the Exchange (if applicable); and</p> <p>(m) to furnish the Exchange on the first day of listing or immediately after the execution of the trust deed/deed poll, whichever is the earlier, a copy of the duly executed trust deed/deed poll together with the letter of compliance accompanied by a checklist showing compliance (if applicable).</p>
<p>_____ [Authorised signatory of the *eligible broker] Name: Designation: Date:</p>		<p>_____ [Authorised signatory of the Issuer] Name: Designation: Date:</p>

** Authorised signatory of the issuer if the issuer is an eligible broker or licensed institution approved by Bank Negara Malaysia, submitting the listing application on its own behalf.*

Part B

Documents to be filed with a listing application for structured warrants

(paragraph 4.1(b))

- (1) An issuer must file the following documents in support of a listing application for structured warrants:
- (a) **Aa** copy of the draft or duly executed trust deed/deed poll whichever applicable_{:-}
 - (b) **Aa** letter of undertaking in the form of Annexure PN27-C duly executed by the issuer together with a certified true extract of the issuer's board of directors' resolution authorising the signatory_{:-}
 - (c) **Aa** letter of undertaking in the form of Annexure PN27-D duly executed by each director of the issuer_{:-}
 - (d) **Aa** letter from the issuer's adviser confirming all approvals of relevant authorities have been obtained, if applicable_{:-}
 - (e) **Aa** copy each of all letters of approval from the relevant authorities, if applicable_{:-}
 - (f) **Aa** timetable for the implementation of the proposal_{:-}
 - (g) **Aa** copy of the prospectus, term sheet and their supplements (where applicable) registered with the relevant authorities or where this is not applicable or available, a copy of the registrable prospectus and/or draft/registrable term sheet and their supplements (where applicable) submitted to the relevant authorities_{:-}
 - (h) **Aa** copy of the latest credit rating on the issuer by the relevant rating agency_{:-}

Annexure PN27-A
Listing application for structured warrants

- (i) ~~Aa~~ copy of the certificate of lodgment of the prospectus with the relevant authorities;
 - (j) ~~Aa~~ checklist showing compliance with Chapter 5 of the Listing Requirements; ~~and-~~
 - (k) ~~Aa~~ all relevant supporting documents evidencing compliance with the eligibility of the issuer and the underlying financial instrument respectively.
- (2) If any of the above documents are not filed because they are not applicable or available in any case, an issuer must submit a separate exhibit explaining why such documents are not applicable or available.

[End of Annexure]

ANNEXURE PN27-B

Part A

Listing application for Further Issue
(paragraph 8.1(a))

1.	Name of Issuer <u>("Issuer")</u>	
2.	Amount and description of each Structured Warrants ("SW") applied for listing	
3.	Amount of each SW in Existing Issue	
4.	Percentage of each SW in Existing Issue held by Issuer and any member of the Issuer's group	
5.	<u>Currency denomination which the SW will be listed and quoted</u>	<p>(a) Ringgit Malaysia ("RM") <input type="checkbox"/></p> <p>(b) Others : _____ <input type="checkbox"/></p> <p><u>In the event the SWs are listed and quoted in currencies other than RM, whether the approval of the Controller of Foreign Exchange has been obtained-?</u></p> <p>_____ Yes <input type="checkbox"/></p> <p>_____ No <input type="checkbox"/></p>
56.	Tentative listing date (to specify)	
67.	Confirmation	<p>We confirm the following:</p> <p>(a) we are in full compliance with the relevant requirements for issuer as stipulated under the SC's Structured Warrants Guidelines.</p> <p>(b) we are in full compliance with the relevant requirements for Further Issue pursuant to paragraph 5.29(1) of Bursa Malaysia Securities Berhad ("Exchange") Main Market Listing Requirements ("LR").</p>

Annexure PN27-B
Listing application for Further Issue

<p>78.</p>	<p>Undertakings</p>	<p>We undertake the following:</p> <ul style="list-style-type: none"> (a) all allotment information of the structured warrants will be submitted to the Depository for the crediting of the structured warrants into the respective securities holders accounts; (b) all conditions, including conditions imposed by the relevant authorities, if any, which are required to be met prior to the listing and quotation of the structured warrants will be met; (c) there are no circumstances or facts which have the effect of preventing or prohibiting the issuance, listing and/or quotation of the structured warrants, including any order, injunction or any other directive issued by any court of law; (d) to immediately inform the Exchange upon becoming aware, after submission of the listing application, that the applicant has failed to meet any of the above undertakings referred to in paragraphs (a) to (b) or of any circumstances or facts referred to in paragraph (c) above; (e) to make the relevant announcements in accordance with paragraph 7.1(i) of Practice Note 27; (f) to furnish the Exchange on the first day of listing, a letter from the eligible broker or if the issuer is an eligible broker or licensed institution approved by Bank Negara Malaysia submitting the application on its own behalf, a letter from the issuer, confirming all approvals of relevant authorities for the issuance of structured warrants have been obtained (if applicable); (g) to furnish the Exchange on the first day of listing, a copy each of all letters of approval from the relevant authorities for the issuance of structured warrants which have not been filed with the Exchange (if applicable); and (h) to furnish the Exchange on the first day of listing or immediately after the execution of the trust deed/deed poll or their supplement, whichever is the earlier, a copy of the duly executed trust deed/deed poll or their supplement in respect of the additional structured warrants together with the letter of compliance accompanied by a checklist showing compliance (if applicable).
<p>_____ [Authorised signatory of the *eligible broker] Name: Designation: Date:</p>		<p>_____ [Authorised signatory of the Issuer] Name: Designation: Date:</p>

* Authorised signatory of the issuer if the issuer is an eligible broker or licensed institution approved by Bank Negara Malaysia, submitting the listing application on its own behalf.

Part B**Documents to be filed with a listing application for Further Issue**
(paragraph 8.1(b))

~~An issuer must file the following documents in support of a listing application for a Further Issue:~~

- (~~a~~1) A copy of the prospectus, term sheet and their supplements (where applicable) registered with the relevant authorities.
- (~~2~~b) A copy of the registrable supplement prospectus (if applicable) and/or draft/registrable term sheet (for Further Issue) submitted to the relevant authorities.
- (~~e~~3) A copy of the latest credit rating on the issuer by the relevant rating agency.
- (~~d~~4) A copy of the certificate of lodgment of the prospectus with the relevant authorities (if applicable).
- (~~e~~5) A checklist showing compliance with paragraph 5.29(1) of the Listing Requirements.
- (~~f~~6) All relevant supporting documents evidencing compliance with paragraph 5.29(1) of the Listing Requirements.

[End of Annexure]

Annexure PN27-C

Undertaking by a director of an issuer of structured warrants

ANNEXURE PN27-C

Undertaking by an issuer for the listing of structured warrants
(paragraph 5.1)

To:

Bursa Malaysia Securities Berhad
Exchange Square
Bukit Kewangan
50200 Kuala Lumpur

Compliance with Main Market Listing Requirements and Rules of Bursa Malaysia Securities Berhad
(“**Bursa Securities**”)

In consideration of Bursa Securities approving our application for admission and official quotation to the Official List of Bursa Securities (“**Official List**”), of all the structured warrants (“**Structured Warrants**”) issued under the prospectus dated [insert date] (“**Prospectus**”) -

- (a) WE ACKNOWLEDGE that the Structured Warrants shall remain on the Official List, and official quotation of any of the Structured Warrants shall continue only during the pleasure of Bursa Securities; and
- (b) WE UNDERTAKE AND AGREE to comply with Bursa Securities Main Market Listing Requirements and the Rules of Bursa Securities, including any amendment which may be made from time to time, insofar as the same apply to us, from the date of the Prospectus until the expiry date of the Prospectus or maturity date of the Structured Warrants, whichever is the later.

**This Undertaking ~~shall be is~~ deemed to have been made in Malaysia and the construction, validity and performance of this Undertaking ~~shall be are~~ governed in all respects by the laws of Malaysia and WE irrevocably submit to the jurisdiction of the Malaysian Courts.

The above Undertaking has been signed by me as [title] of [Issuer] pursuant to the authority granted to me by resolution of the board of directors of the issuer on

Date:

Signature:

Name:

** Applicable to a foreign issuer only.

[End of Annexure]

Annexure PN27-D
Undertaking by a director of an issuer of structured warrants

ANNEXURE PN27-D

Undertaking by a director of an issuer of structured warrants
(paragraph 5.2; paragraph 5.37 of the Listing Requirements)

To:

Bursa Malaysia Securities Berhad
Exchange Square
Bukit Kewangan
50200 Kuala Lumpur

Compliance with Main Market Listing Requirements

I, [name ~~and NRIC number~~ of director], am a director of[name of issuer] ("**Company**") which

- (a) #has submitted an application to admit to the Official List of Bursa Malaysia Securities Berhad ("**Bursa Securities**"), all the structured warrants ("**Structured Warrants**") issued under the prospectus dated [insert date] ("**Prospectus**"); or
- (b) #whose structured warrants issued under the prospectus dated [insert date] ("**Prospectus**") are listed on the Official List of Bursa Malaysia Securities Berhad ("**Bursa Securities**") ("**Structured Warrants**").

In consideration of Bursa Securities #approving the Company's application for the listing of Structured Warrants on the Official List / allowing the continued listing of the Structured Warrants of the Company on the Official List, I UNDERTAKE AND AGREE to comply with Bursa Securities Main Market Listing Requirements, including any amendment which may be made from time to time, insofar as the same shall apply to me as a director of the Company, from the date of the Prospectus until the expiry date of the Prospectus or maturity date of the Structured Warrants, whichever is the later.

**This Undertaking is deemed to have been made in Malaysia and the construction, validity and performance of this Undertaking are governed in all respects by the laws of Malaysia and I irrevocably submit to the jurisdiction of the Malaysian Courts.

Yours faithfully,

.....

Name:

NRIC No. (Old & New):**Passport No. & Country of Issuance:

Designation:

Date:

Delete as appropriate

**Annexure PN27-D
Undertaking by a director of an issuer of structured warrants**

** Applicable to a foreign director only.

[End of Annexure]

BURSA MALAYSIA SECURITIES BERHAD

PRACTICE NOTE 28

LISTING PROCEDURES FOR NEW ISSUES OF SECURITIES

Details	Cross References
Effective date: 3 August 2009	Paragraphs 6.17, 6.29, 6.36, 6.49, 6.59, 6.60

1.0 Introduction

- 1.1 This Practice Note sets out the following requirements in relation to an application for listing of new issues of securities under Chapter 6 of the Listing Requirements:
- (a) the procedures for listing of new issues of securities;
 - (b) the listing and quotation (where applicable) application form and supporting documents; and
 - (c) other relevant requirements.
- 1.2 In relation to a new issue of securities pursuant to or which will result in a significant change in business direction or policy of a listed corporation, the listed corporation must comply with the requirements under Practice Note 21, where applicable, as if it were an applicant seeking admission to the Official List. However, when such a listed corporation issues new securities, the listed corporation must also comply with the requirements under this Practice Note, where applicable.

PART I APPLICATION PROCEDURES AND ADMISSION PROCESS

2.0 Procedures relating to listing of a new issue of securities

- 2.1 The following procedures apply to the listing of new issues of securities by a listed issuer which do not fall within paragraphs 3.0 or 4.0, with the necessary modifications, as may be applicable:—
- (a) listed issuer immediately announces the new issue of securities to the Exchange upon the approval of the board of directors of the listed issuer;
 - (b) listed issuer files with the Exchange a listing application for the new issue of securities together with supporting documents and draft circular for the Exchange's review, where applicable;
 - (c) Exchange grants approval-in-principle for the listing of the new issue of securities and confirms that it has no further comments on the draft circular;
 - (d) listed issuer obtains shareholder approval, if required;

Practice Note 28
Listing Procedures for New Issues of Securities

- (e) listed issuer fixes relevant books closing and entitlement dates, where applicable and immediately announces such dates to the Exchange;-
- (f) listed issuer issues and allots the securities;
- (g) listed issuer files with the Exchange a quotation application together with supporting documents; and
- (h) securities are admitted to the Official List and quoted on the Exchange 2 market days after receipt of the quotation application together with the requisite documents and/or confirmations and the same have been found to be complete in all respects.

3.0 Procedures relating to listing of a bonus issue of securities and listing of convertibles securities arising from the bonus issue

3.1 The following procedures apply to the listing of -

- (a) a bonus issue of securities by a listed issuer; and
- (b) any issue of convertible securities arising from adjustments due to the bonus issue ("**consequential securities**"),

with the necessary modifications, as may be applicable:

- (i) listed issuer immediately announces the bonus issue to the Exchange upon the approval of the board of directors of the listed issuer;
- (ii) listed issuer files with the Exchange a listing application for the bonus issue and the consequential securities, if any, together with supporting documents;
- (iii) Exchange grants approval for the listing and quotation of the bonus issue securities and consequential securities, if any;
- (iv) listed issuer obtains shareholder approval;
- (v) listed issuer fixes the books closing date for the bonus issue and consequential securities, if any, and immediately announces such dates to the Exchange in accordance with paragraph 6.35 of the Listing Requirements;
- (vi) listed issuer issues and allots the securities. Where the bonus issue is a Specified Bonus Issue, the listed issuer must issue and allot the securities on the books closing date;
- (vii) listed issuer announces to the Exchange the number of securities which will be listed and quoted; and
- (viii) securities are admitted to the Official List and quoted on the Exchange. Where the bonus issue is a Specified Bonus Issue, the bonus issue securities and consequential securities, if any, are admitted to the Official List and quoted on the Exchange on the next market day after the books closing date.

Practice Note 28
Listing Procedures for New Issues of Securities

4.0 Procedures relating to the listing of additional securities of the same type and class

4.1 The procedures in paragraph 4.2 below apply to the listing of additional securities, with the necessary modifications, as may be applicable, where the additional securities will be listed and quoted as the existing listed securities of the same type and class.

4.2 The procedures referred to in paragraph 4.1 are as follows:

- (a) listed issuer immediately announces the new issue of securities to the Exchange upon the approval of the board of directors of the listed issuer being given;
- (b) listed issuer files with the Exchange a listing application for the additional securities together with supporting documents and draft circular for the Exchange's review, where applicable;
- (c) Exchange grants approval for the listing of the additional securities and confirms that it has no further comments on the draft circular;
- (d) listed issuer obtains its shareholder approval, if required;
- (e) listed issuer fixes relevant books closing and entitlement dates, where applicable and immediately announces such dates to the Exchange;
- (f) listed issuer issues and allots the additional securities;
- (g) listed issuer announces listing of the additional securities in accordance with paragraph 13.2 below; and
- (h) additional securities are listed and quoted on the Exchange.

4.3 The procedures in paragraph 4.2 above do not apply to the issuance of additional securities -

- (a) which is conditional upon any other corporate proposal which involves -
 - (i) issuance of additional securities which will not be listed and quoted as the existing listed securities of the same class; or
 - (ii) issuance of a new type of securities, or
- (b) which securities are attached with a new type of securities.

4.4 For the purpose of this paragraph, "**additional securities**" refers to a further issue of the same type and class of listed securities.

5.0 Summary of listing procedures

5.1 Annexure PN28-A summarises the application of listing procedures set out in paragraphs 2.0, 3.0 and 4.0 above.

Practice Note 28
Listing Procedures for New Issues of Securities

6.0 Listing and quotation application form and supporting documents

- 6.1 A listed issuer must file with the Exchange a listing application for a new issue of securities which consists of the following:
- (a) the application, in the form of Part A of Annexure PN28-B; and
 - (b) the supporting documents specified in Part B of Annexure PN28-B.
- 6.2 Subject to paragraph 6.3 below, a listed issuer must also file with the Exchange a quotation application of a new issue of securities which is accompanied by the documents specified in Part C of Annexure PN28-B and such other documents as may be specified in the approval-in-principle granted by the Exchange.
- 6.3 A quotation application is not required for a listing application which is subject to the procedures of listing as set out in paragraphs 3.0 and 4.0 above.

7.0 Listing and quotation application form for debt securities

- 7.1 For a listing application for debt securities, in addition to the documents set out in paragraph 6.1 above, a listed issuer must also include the following:
- (a) the information set out in Part D of Annexure PN28-B, subject to the necessary adaptations; and
 - (b) the supporting documents specified in Part E of Annexure PN28-B.

8.0 Listing and quotation application for convertible securities

- 8.1 For a listing application for convertible securities, in addition to the documents set out in paragraph 6.1 above, a listed issuer must also file with the Exchange together with the listing application, the supporting documents specified in Part F of Annexure PN28-B.

9.0 Listing and quotation application for exchange-traded funds

- 9.1 A management company must file with the Exchange a listing application in respect of all new units to be issued in connection with the application which consists of the following:
- (a) the application, in the form of Annexure PN28-C, subject to the necessary modifications; and
 - (b) the supporting documents specified in Part B of Annexure PN28-B.

PART II OTHER RELEVANT REQUIREMENTS**10.0 Listing of issued and unissued securities**

- 10.1 A listed issuer must comply with paragraph 6.0 of Practice Note 21 as if it were the applicant, with the necessary modifications. For this purpose, the “**approval**” referred to in paragraph 6.0 of Practice Note 21 includes an “**approval-in-principle**”.

Practice Note 28
Listing Procedures for New Issues of Securities

11.0 Crediting of securities

- 11.1 Subject to paragraph 11.3 below, a listed issuer must ensure that all new issues of securities for which listing is sought are by way of crediting the securities accounts of the allottees with such securities.
- 11.2 For the above purpose, the listed issuer must notify the Depository of all such particulars required by the Depository, to enable the Depository to make the appropriate entries in the securities accounts of such allottees.
- 11.3 Paragraph 11.1 above does not apply where a listed issuer is specifically exempted from compliance with section 38 of the Securities Industry (Central Depositories) Act 1991.

12.0 Issue or allotment of securities

- 12.1 A listed issuer must not issue or allot securities until after it has filed with the Exchange a listing application for such new issue of securities and has been notified by the Exchange that such new issue of securities has been approved or approved in principle for listing, as the case may be.

13.0 Announcement in relation to a new issue or issue of securities

- 13.1 If a listed issuer fails to make an application to the SC or the Exchange by the date specified in the announcement made under paragraphs 2.0, 3.0 or 4.0 above, it must immediately announce to the Exchange the fact of such failure, its reasons and **and** when it expects to make the application.
- 13.2 Where the additional securities are listed in accordance with the procedures set out in paragraph 4.0 above, a listed issuer must announce the following information immediately upon receipt of confirmation from the Depository that the securities are ready to be credited into the securities accounts of the respective holders:
- (a) details of the corporate proposal;
 - (b) total number of securities issued under each proposal and the issue price per share, if any;
 - (c) date of listing and quotation; and
 - (d) latest issued and paid-up capital of the listed issuer after the proposal indicating the number of shares (in unit and RM) and their par value, if any.

Annexure PN28-A
Summary of listing procedures

ANNEXURE PN28-A

Summary of listing procedures
(paragraph 5.0)

No.	Proposals	Procedures Applicable (paragraph of Practice Note 28)	Quotation Application Required?	Listing Date
Bonus Issue				
A	A bonus issue of securities ("BI") which is a Specified Bonus Issue	3.0	No	B + 1
B	BI which is conditional upon D	3.0	No	Relevant Date
	D	4.0	No	Relevant Date
C	BI which is conditional upon— (i) E; or (ii) F; or (iii) E or F, and D or (iv) E, F, and D	3.0	No	Relevant Date (which must be Q + 2 of D, E, F)
	D, E, F	2.0	Yes	Q + 2
Others				
D	Proposal which involves issuance of additional securities which will be listed and quoted as the existing listed securities of the same class and is not conditional upon E or F	4.0	No	Relevant Date
E	Proposal which involves issuance of additional securities which will not be listed and quoted as the existing listed securities of the same class	2.0	Yes	Q + 2

Annexure PN28-A
Summary of listing procedures

No.	Proposals	Procedures Applicable (paragraph of Practice Note 28)	Quotation Application Required?	Listing Date
F	Proposal which involves issuance of new type of securities e.g. warrants, irredeemable convertible unsecured loan stocks (ICULS), preference shares, etc.	2.0	Yes	Q + 2
G	Proposal which involves issuance of additional securities which will be listed and quoted as the existing listed securities of the same class and such additional securities are attached with a new type of securities.	2.0	Yes	Q + 2

Definition and Interpretation

- (a) "B" means books closing date.
- (b) "BI" means a bonus issue of securities.
- (c) "Q" means the date on which the quotation application is submitted to the Exchange.
- (d) "Relevant Date" has the meaning given to it in paragraph 6.35(3) of the Listing Requirements.
- (e) "Specified Bonus Issue" has the meaning given to it in paragraph 6.01(4) of the Listing Requirements.

[End of Annexure]

Annexure PN28-B
Listing application for a new issue of securities

ANNEXURE PN28-B

Part A

Listing application in relation to a new issue of securities

(paragraphs 6.1(a), 7.1 and 7.2)

Please tick wherever applicable. If not applicable, please indicate "N/A"
[You may tick more than one box, where applicable]

Delete as appropriate

1.	Name of Corporation	
2.	Types of corporate proposal	<p>(a) Acquisitions (which do not result in a significant change in business direction or policy of the listed corporation) <input type="checkbox"/></p> <p>(b) Rights hissue <input type="checkbox"/></p> <p>(c) Special hissue <input type="checkbox"/></p> <p>(d) Private Placement <input type="checkbox"/></p> <p>(e) Bonus hissue <input type="checkbox"/></p> <p>(f) Share Sscheme for Employees (ESOS) <input type="checkbox"/></p> <p>(g) Others: _____ <input type="checkbox"/></p>
	Percentage Ratios (where applicable)	<p>(a) Acquisition of _____.....%</p> <p>_____</p> <p>_____</p> <p>(b) Acquisition of _____.....%</p> <p>_____</p> <p>_____</p> <p>(c) Acquisition of _____.....%</p> <p>_____</p> <p>_____</p>
3.	Confirmation by listed issuer	<p>We, the listed issuer, confirm that we -</p> <p>(a) #have/have not been convicted or charged with any offence under the securities laws, corporations laws or other laws involving fraud or dishonesty in a court of law, for the last 10 years before the submission; and</p>

Annexure PN28-B
Listing application for a new issue of securities

<p>9.</p>	<p><u>Currency denomination which the new securities will be listed and quoted</u></p>	<p>(a) Ringgit Malaysia ("RM") <input type="checkbox"/></p> <p>(b) Others : (Please indicate)</p> <p>-----</p> <p><u>In the event the new securities are listed and quoted in currencies other than RM, whether the approval of the Controller of Foreign Exchange has been obtained?</u></p> <p>Yes <input type="checkbox"/></p> <p>No <input type="checkbox"/></p>
<p>910.</p>	<p>Ranking of the new securities</p>	<p>The new securities #will/will not be listed and quoted as the existing listed securities of the same class.</p> <p>If the new securities will be separately quoted on listing date, details of the non-entitlement(s):</p> <p>_____</p> <p>_____</p>
<p>101.</p>	<p>Debt securities</p>	<p>Additional information for debt securities as set out in Part D of Annexure PN28-B is attached <input type="checkbox"/></p>
<p>142.</p>	<p>Directorships and/or substantial shareholdings of the controlling shareholder</p>	<p>A list setting out directorships and/or substantial shareholdings of the controlling shareholder(s) in all other listed issuers in Malaysia for the past 3 years, is attached. <input type="checkbox"/></p>
<p>123.</p>	<p>Issuance of securities on non-pro rata basis</p>	<p>Where the new issuance of securities is on a non-pro rata basis –</p> <p>A list setting out the class of placees (i.e. whether they are public investors, Bumiputera investors or directors/substantial shareholders of the applicant) and the amount of securities to be allocated to each placee or each class of placees, is attached herewith. <input type="checkbox"/></p> <p>Note: Where the identified placees are nominee corporations or funds, the names of the ultimate beneficiaries must be disclosed.</p>
<p>15E 14.</p>	<p>Conditionality of Pproposals/ Ppricing</p>	<p>(a) The issue price # is/is not conditional upon any other proposal</p> <p>(b) This proposal #is/is not conditional upon any other proposal</p> <p>If in the affirmative, to provide details of the other corporate exercises, including the estimated time frame for completion:</p> <p>_____</p>

Annexure PN28-B
Listing application for a new issue of securities

<p>15F 15.</p>	<p>Public Sshareholding Sspread</p>	<p>(a) <u>ORDINARY SHARES</u></p> <p>Where the proposal results in non-compliance with paragraph 8.02(1) of the LR, details of the public shareholdings as per Part B(1)(d) Annexure PN21-A of the LR and the reasons are attached. <input type="checkbox"/></p> <p>(b) <u>CONVERTIBLE SECURITIES/ PREFERENCE SHARES</u></p> <p>(i) There will be more than 100 holders <input type="checkbox"/></p> <p>(ii) There will be less than 100 holders <input type="checkbox"/></p> <p>In the event of (ii), to provide reasons: _____</p> <p>_____</p>
<p>136. SHARE SCHEME FOR EMPLOYEES (“ESOS”)</p>		
<p>136 A</p>	<p>Confirmation</p>	<p>We confirm that the ESOS is in full compliance with Part G- of Chapter 6 of the LR</p>
<p>147. BONUS ISSUE & TWO-CALL RIGHTS ISSUE</p>		
<p>147 A</p>	<p>Confirmation of compliance and adequacy of reserves</p>	<p>(a) The Bbonus issue/two-call rights issue is in full compliance with paragraph 6.30 of the LR <input type="checkbox"/></p> <p>(b) The reporting accountant or external auditor has confirmed that the available reserves for capitalisation are adequate to cover the entire bonus issue/two-call rights issue in accordance with paragraph 6.30(3), if applicable <input type="checkbox"/></p>
<p>147 B</p>	<p>Bonus issue/two-call rights issue will be fully capitalized from the following:</p>	<p>(a) Retained Profit Account <input type="checkbox"/></p> <p>(b) Share Premium Account <input type="checkbox"/></p> <p>(c) Surplus arising from the revaluation of investments in subsidiaries and associated companies <input type="checkbox"/></p> <p>(d) Surplus arising from the revaluation of land and building-estate _____ (at least 20% or 10% in the case of a real estate investment trust, of the valuation amount will be retained) <input type="checkbox"/></p>
<p>147 C</p>	<p>Conditionality</p>	<p>(a) The Bbonus issue/two-call rights issue is not conditional upon another corporate proposal <input type="checkbox"/></p> <p>(b) The Bbonus issue/two-call rights issue is conditional upon a concurrent subdivision or consolidation <input type="checkbox"/></p> <p>(c) The Bbonus issue/two-call rights issue is conditional upon another corporate proposal. <input type="checkbox"/></p> <p>To specify details of the other corporate proposals and the estimated time frame for completion of the same</p> <p>_____</p>

Annexure PN28-B
Listing application for a new issue of securities

<p>147 D</p>	<p>Undertakings for Bonus Issues/two-call rights issue</p>	<p>We undertake the following:</p> <ul style="list-style-type: none"> (a) the return of allotment will be filed with the Registrar of Companies pursuant to the Companies Act, 1965 or in relation to a foreign corporation, the relevant document showing its latest issued and paid-up capital will be filed with the relevant authority pursuant to the laws of the place of incorporation; (b) all notices of allotment will be issued and despatched to the entitled holders as expeditiously as possible and in any event, not later than 4 market days after the date of listing and quotation; (c) the new securities will be listed and quoted as the existing listed securities of the same class; (d) all conditions, including conditions imposed by the relevant authorities, if any, which are required to be met before the listing and quotation of the securities will be met; (e) there are no circumstances or facts which have the effect of preventing or prohibiting the issuance, listing and/or quotation of the securities including any order, injunction or any other directive issued by any court of law; and (f) to immediately inform the Exchange upon becoming aware, after submission of the listing application, that the listed issuer has failed to meet any of the above undertakings referred to in paragraphs (a) to (d) or of any circumstances or facts referred to in paragraph (e) above.
<p>158.</p>	<p>ISSUES OF SECURITIES ON A NON-PRO RATA BASIS UNDER A GENERAL MANDATE</p>	
<p>158 A</p>	<p>Confirmation from Principal Adviser</p>	<p>We confirm that –</p> <ul style="list-style-type: none"> (i) Paragraph 6.03 of the LR has been complied with <input type="checkbox"/> (ii) Paragraph 6.04 of the LR has been complied with <input type="checkbox"/>
<p>169.</p>	<p>CORPORATE PROPOSALS WHICH FALL UNDER PARAGRAPH 4.0 OF PRACTICE NOTE 28</p>	
<p>169 A</p>	<p>Undertakings for corporate proposals which apply the procedure under paragraph 4.0</p>	<p>We undertake the following:</p> <ul style="list-style-type: none"> (a) the return of allotment will be filed with the Registrar of Companies pursuant to the Companies Act, 1965 or in relation to a foreign corporation, the relevant document showing its latest issued and paid-up capital will be filed with the relevant authority pursuant to the laws of the place of incorporation; (b) all notices of allotment will be issued and despatched to the entitled holders as expeditiously as possible and in any event, not later than 4 market days after the date of listing and quotation;

Annexure PN28-B
Listing application for a new issue of securities

		<p>(c) the new securities will be listed and quoted as the existing listed securities of the same class;</p> <p>(d) all conditions, including conditions imposed by the relevant authorities, if any, which are required to be met before the listing and quotation of the securities will be met;</p> <p>(e) there are no circumstances or facts which have the effect of preventing or prohibiting the issuance, listing and/or quotation of the securities including any order, injunction or any other directive issued by any court of law;</p> <p>(f) to immediately inform the Exchange upon becoming aware, after submission of the listing application, that the listed issuer has failed to meet any of the above undertakings referred to in paragraphs (a) to (d) or of any circumstances or facts referred to in paragraph (e) above; and</p> <p>(g) to announce to the Exchange the relevant information in accordance with paragraph 13.2 of Practice Note 28.</p>
<p>_____ [Authorised signatory of the Principal Adviser] Name: Designation: Date:</p>		<p>_____ [Authorised signatory of the listed issuer] Name: Designation: Date:</p>

Part B**Documents to be filed with a listing application for a new issue of securities**

(paragraphs 6.1(b), 7.1, 8.1 and 9.1)

- (1) A listed issuer must file the following documents in support of a listing application for a new issue of securities:
- (a) a copy of the announcement, circular, prospectus or abridged prospectus which is registered with the relevant authorities;
 - (b) a certified true copy of the relevant resolution passed by securities holders in general meeting;
 - (c) a letter from the listed issuer's Principal Adviser confirming all approvals of relevant authorities have been obtained;
 - (d) a copy each of all letters of approval from the relevant authorities;
 - (e) in the case of a share scheme for employees, a draft copy of the bylaws; and
 - (f) for proposals which apply the procedures under paragraphs 3.0 and 4.0 of Practice Note 28, a cheque drawn to the order of Bursa Malaysia Securities Berhad for the processing and listing fees (see the Schedule of Fees for the computation of the amount), together with a copy of the details of the computation of the amount of listing fees payable.

Annexure PN28-B
Listing application for a new issue of securities

- (2) If any of the above documents are not filed because they are not applicable or available in any case, a listed issuer must submit a separate exhibit explaining why such documents are not applicable or available.

Part C**Documents to be filed with a quotation application for a new issue of securities**

(paragraph 6.2)

A listed issuer must file the following documents in support of quotation application for a new issue of securities:

- (a) a confirmation from the listed issuer as to its latest issued and paid-up capital;
- (b) a confirmation that all notices of allotment have been issued and despatched to the entitled holders;
- (c) a confirmation from the listed issuer that the Depository is ready to credit the new securities to the accounts of the entitled holders, after receiving the allotment information for crediting of the new securities;
- (d) a cheque drawn to the order of Bursa Malaysia Securities Berhad for the listing fees (see Schedule of Fees for computation of amount) together with a copy of the details of the computation of the amount of listing fees payable;
- (e) a confirmation from the Principal Adviser of whether the new issue of securities will be listed and quoted as the existing securities of the same class or will be separately quoted on the listing date. If the new issue of securities will be separately quoted on the listing date, to specify the entitlement that the holders of the new issue of securities will not be entitled to;
- (f) a confirmation from the Principal Adviser that all conditions, including conditions imposed by the relevant authorities, if any, which are required to be met before the listing and quotation of the securities have been met;
- (g) a confirmation from the Principal Adviser that there are no circumstances or facts which have the effect of preventing or prohibiting the issuance, listing and/or quotation of the securities including any order, injunction or any other directive issued by any court of law; and
- (h) such other documents which are not/-have not been submitted pursuant to Part B of Annexure PN28-B.

Part D**Additional information for debt securities**

(paragraph 7.1(a))

- (1) The full title of issue and ranking of the debt securities.†
- (2) The title of instrument under which the debt securities were created or are proposed to be created.†
- (3) The name of trustee.†
- (4) The issue and maturity dates.†

Annexure PN28-B
Listing application for a new issue of securities

- (5) The amount authorised, amount issued to-date, amount retired, amount outstanding and amount proposed to be issued.;
- (6) The interest rate and interest payment dates.;
- (7) The method of redemption.;
- (8) Whether the issue qualifies for any tax exemption.;
- (9) The denominations issuable.;
- (10) The manager and lead underwriter of the issue.;
- (11) The method of distribution of the issue.;
- (12) Whether bank guaranteed and if so, details of the amount guaranteed by the respective guarantor banks.;
- (13) Whether secured and if so, details of such security.;
- (14) A summary of other material terms of issue.

Part E**Additional supporting documents to be filed with a listing application for debt securities**

(paragraph 7.1(b))

- (1) A listed issuer must file the following additional documents in support of a listing application for debt securities:
 - (a) a copy of the mortgage indenture, or equivalent instrument certified by the trustee; and
 - (b) a copy of the duly executed trust deed.
- (2) If any of the above documents are not filed because they are not applicable in any case, a listed issuer must submit a separate exhibit explaining why such documents are not applicable.

Part F**Additional supporting documents to be filed with a listing application for convertible securities**

(paragraph 8.1)

- (1) A listed issuer must file a copy of the duly executed deed poll in support of a listing application for convertible securities.
- (2) If the above document is not filed because it is not applicable in any case, a listed issuer must submit a separate exhibit explaining why the document is not applicable.

[End of Annexure]

Annexure PN28-C
Listing application for new issue of units
for an exchange-traded fund

ANNEXURE PN28-C

Listing application for new issue of units for an exchange-traded fund
 (paragraph 9.1)

1.	Name of Fund	
2.	Name of management company	
3.	Types of proposal including number of new units applied for listing and issue price (if any)	(a) In-kind creation <input type="checkbox"/> (c) Others: _____ <input type="checkbox"/>
4.	Undertakings	We undertake the following: (a) all notices of allotment will be issued and despatched to all successful unit holders upon creation of the new units; (b) all new units issued will rank pari passu in all respects with the existing units; (c) all allotment information will be submitted to the Depository for the crediting of units issued; (d) all conditions, including conditions imposed by the relevant authorities, will be met upon the creation of the new units; (e) there will be no circumstances or facts which have the effect of preventing or prohibiting the issuance, listing and/or quotation of the units, including any order, injunction or any other directive issued by any court of law; and (f) to immediately inform the Exchange upon becoming aware, after submission of the listing application, that the applicant has failed to meet any of the above undertakings referred to in paragraphs (a) to (d) or of any circumstances or facts referred to in paragraph (e) above.
_____ [Authorised signatory of the Principal Adviser] Name: Designation: Date:		_____ [Authorised signatory of the management company] Name: Designation: Date:

BURSA MALAYSIA SECURITIES BERHAD

PRACTICE NOTE 29

SAVING AND TRANSITIONAL PROVISIONS

Details	Cross References
Revision date: 3 August 2009	Paragraph 8.03, 8.04, 13.04, 13.05 and 16.11

1.0 Introduction

- 1.1 This Practice Note sets out the requirements that must be complied with by the relevant listed issuers arising from the amendments to paragraphs 8.03 and 8.04, Practice Notes 16 and 17 of the Listing Requirements with effect from 3 August 2009.
- 1.2 This Practice Note applies to the following listed issuers which are subjected to the following Listing Requirements prior to 3 August 2009:
- (a) **PN4 Companies** - paragraph 8.14 and Practice Note No 4/2001 from 15 February 2001 to 2 January 2005 ("**PN 4 Framework**", as set out in Annexure PN29-A);
 - (b) **PN10 Companies** - paragraph 8.16 and Practice Note No 10/2001, from 15 January 2001 to 2 January 2005 ("**PN 10 Framework**" as set out in Annexure PN29-B);
 - (c) **Original PN16 Companies** - paragraph 8.14B and Practice Note No 16/2005 from 3 January 2005 to 4 May 2006 ("**Original PN16 Framework**", as set out in Annexure PN29-C);
 - (d) **Original PN17 Companies** - paragraph 8.14C and Practice Note No 17/2005 from 3 January 2005 to 4 May 2006 ("**Original PN17 Framework**", as set out in Annexure PN29-D);
 - (e) **Amended PN16 Companies** - amended paragraph 8.14B and Practice Note No 16/2005 from 5 May 2006 to 2 August 2009 ("**Amended PN16 Framework**", as set out in Annexure PN29-E); **and**
 - (f) **Amended PN17 Companies** – amended paragraph 8.14C and Practice Note No 17/2005 from 5 May 2006 to 2 August 2009 ("**Amended PN17 Framework**", as set out in Annexure PN29-F).

2.0 Saving and Transitional Provisions for PN 4 and PN 10 Companies

- 2.1 The repeal of PN 4 Framework and PN 10 Framework with effect from 3 January 2005 shall not in any way affect the obligations of the listed issuers which -
- (a) triggered any of the criteria set out in paragraph 2.1 of PN4; or
 - (b) had been determined by the Exchange as having inadequate level of operations to warrant continued trading, listing or both, on the Official List pursuant to PN10 Framework,

before 3 January 2005.

- 2.32 The PN4 and PN10 Companies must continue to comply with their obligations under the PN 4 Framework or PN 10 Framework, as the case may be.

3.0 Saving and transitional provision for Original PN16 and PN17 Companies

- 3.1 The amendments to the Original PN16 Framework and Original PN17 Framework with effect from 5 May 2006 shall not in any way affect the obligations of the listed issuers which -

- (a) had been considered a Cash Company pursuant to paragraph 8.14B; or
- (b) triggered any of the criteria set out in paragraph 2.1 of PN17,

before 5 May 2006-.

- 3.2 The Original PN16 and PN17 Companies must continue to comply with their obligations under the Original PN16 and PN17 Framework.

4.0 Saving and transitional provision for Amended PN16 and PN17 Companies

- 4.1 The amendments to the Amended PN16 Framework and Amended PN17 Framework with effect from 3 August 2009 shall not in any way affect the obligations of the listed issuers which -

- (a) had been considered a Cash Company pursuant to paragraph 8.14B; or
- (b) triggered any of the criteria set out in paragraph 2.1 of PN17,

before 3 August 2009.

- 4.2 Subject to paragraph 4.3 below, the Amended PN16 and Amended PN17 Companies must continue to comply with their obligations under the Amended PN16 and Amended PN17 Framework, as the case may be.

- 4.3 Notwithstanding paragraph 4.2 above, an Amended PN16 Company or Amended PN17 Company may apply to the Exchange to regularise its condition under paragraph 8.03 and PN16 or paragraph 8.04 and PN17 of the Listing Requirements which come into effect on 3 August 2009, provided that such Amended PN16 or Amended PN17 Company is still within the stipulated or extended timeframe granted by the Exchange to submit its proposal or plan to regularise its condition under the Amended PN16 or Amended PN17 Framework, as the case may be.

ANNEXURE PN29-A**PN4 Framework**
(paragraphs 1.2(a), 2.1 and 2.2)**[Reproduction of Paragraph 8.14]****“8.14 Financial condition**

- (1) The financial condition of a listed issuer on a consolidated basis must, in the opinion of the Exchange, warrant continued trading and/or listing on the Official List. If the financial condition of a listed issuer on a consolidated basis does not, in the opinion of the Exchange, warrant continued listing on the Official List, the Exchange may de-list such listed issuer.
- (2) The Exchange may prescribe certain criteria in relation to the financial condition of a listed issuer, the fulfillment of which would require the listed issuer and/or its directors to comply with subparagraph (3) below.
- (3) Where a listed issuer fulfils one or more of the criteria prescribed by the Exchange pursuant to subparagraph (2) above, such listed issuer and/or its directors must -
 - (a) regularise its financial condition within such timeframes as may be stipulated by the Exchange;
 - (b) provide such information or document as may be prescribed by the Exchange from time to time, whether for public release or for the Exchange’s information;
 - (c) where it fulfils one or more of the criteria prescribed by the Exchange for the appointment of a monitoring accountant, appoint an independent accounting firm as the monitoring accountant, to perform such functions as may be specified by the Exchange and to report to the Exchange and the listed issuer on a periodic basis; and
 - (d) do all such acts or things as may be directed by the Exchange, from time to time.
- (4) Any cost incurred as a result of the appointment of the monitoring accountant pursuant to subparagraph (3)(c) above shall be borne by the listed issuer.
- (5) None of the above provisions shall be construed to constitute the monitoring accountant as an agent of the Exchange.”

[Reproduction of Practice Note No 4/2001]

“KUALA LUMPUR STOCK EXCHANGE

PRACTICE NOTE NO 4/2001

CRITERIA AND OBLIGATIONS PURSUANT TO PARAGRAPH 8.14 OF THE LISTING REQUIREMENTS

Issued in relation to paragraphs 8.14, 16.02 and 16.09 of the Listing Requirements;

And

Pursuant to paragraph 2.08 of the Listing Requirements.

1.0 Introduction

1.1 This Practice Note sets out, amongst others, the following:-

- (a) the criteria in relation to the financial condition of a listed issuer, the fulfilment of one or more of which will require a listed issuer and/or its directors to comply with the provisions of this Practice Note (a listed issuer which fulfils one or more of the aforesaid criteria shall hereinafter be referred to as “an affected listed issuer”);
- (b) the requirements that must be complied with by an affected listed issuer; and
- (c) the actions that may be taken by the Exchange in respect of an affected listed issuer.

1.2 Unless otherwise extended by the Exchange, an affected listed issuer has a maximum timeframe of between 6 to 12 months to implement its plans to regularise its financial condition.

1.3 An affected listed issuer that fails to comply with the obligations set out under this Practice Note may be suspended and/or de-listed.

1.4 The Exchange will accord due process to an affected listed issuer prior to effecting any suspension and/or de-listing.

2.0 Criteria

2.1 Pursuant to paragraph 8.14(2) of the Listing Requirements, the Exchange prescribes the following criteria, the fulfilment of one or more of which will require an affected listed issuer and/or its directors to comply with the provisions of this Practice Note :-

- (a) deficit in the adjusted shareholders' equity of the listed issuer on a consolidated basis;
- (b) receivers and/or managers have been appointed over the property of the listed issuer, or over the property of its major subsidiary or major associated company which property accounts for at least 70% of the total assets employed of the listed issuer on a consolidated basis;
- (c) the auditors have expressed adverse or disclaimer opinion in respect of the listed issuer's going concern, in its latest audited accounts; or

-
- (d) special administrators have been appointed over the listed issuer or the major subsidiary or major associated company of the listed issuer pursuant to the provisions of the Pengurusan Danaharta Nasional Berhad Act 1998.

2.2 For the purposes of this Practice Note:-

- (a) “adjusted shareholders’ equity” is defined as the residual interest in the assets of a listed issuer on a consolidated basis after deducting all its liabilities, based on the listed issuer’s audited accounts or unaudited accounts. The components of adjusted shareholders’ equity will include the following:
- (i) share capital;
 - (ii) share premium account;
 - (iii) capital redemption reserves;
 - (iv) revaluation reserves;
 - (v) translation reserves;
 - (vi) retained profit/accumulated loss; and
 - (vii) other reserves and/or any other components as determined by the Exchange.

For the purposes of this definition, redeemable preference shares and negative goodwill or reserves on consolidation shall be excluded from the determination of adjusted shareholders’ equity. In addition, in determining the components of “other reserves and/or any other components”, in the absence of any provisions in the approved accounting standards and/or the Companies Act 1965, the Exchange will take into consideration the application of the generally accepted accounting principles and the best current practices and the Exchange’s treatment of this component shall prevail; and

- (b) “a major subsidiary” means a subsidiary which contributes 70% or more of the profits before tax or total assets employed of the listed issuer on a consolidated basis.

3.0 Obligations of an affected listed issuer

3.1 An affected listed issuer must comply with the following obligations:-

- (a) provide such information or document as prescribed in paragraph 4.1 below;
- (b) regularise its financial condition within the time schedule stipulated in paragraph 5.1 below; and
- (c) appoint a monitoring accountant, where it fulfils the criteria set out in paragraph 6.1 below.

4.0 Disclosure obligations of the affected listed issuer

4.1 An affected listed issuer must comply with the following disclosure requirements. An affected listed issuer must:-

- (a) within 7 market days from the date of this Practice Note or from the date a listed issuer fulfils one or more of the criteria prescribed pursuant to paragraph 8.14(2) of the Listing Requirements, whichever shall be the later, announce the following (“the First Announcement”):-

- (i) the listed issuer is an affected listed issuer pursuant to this Practice Note;
 - (ii) the obligations of the listed issuer pursuant to this Practice Note;
 - (iii) the consequences of non-compliance with such obligations; and
 - (iv) the status of the listed issuer's plan to regularise its financial condition or the status of its endeavours to formulate such a plan, whichever is applicable, or where neither a plan nor any endeavour to formulate such a plan has been undertaken, an appropriate negative statement to such effect;
- (b) announce the status of its plan to regularise its financial condition on a monthly basis until further notice from the Exchange;
 - (c) announce its compliance or failure to comply with a particular obligation imposed pursuant to this Practice Note, as and when such obligation becomes due; and
 - (d) submit monthly reports to the Exchange ("the Monthly Reports") in the manner set out in paragraph 4.2 below, accompanied by statutory declarations as provided in paragraph 4.5 below.

4.2 The Monthly Reports must include the following:-

- (a) details of all related party transactions entered into by an affected listed issuer and its subsidiaries in the month reported, irrespective of the value of the transactions and regardless of whether or not such transactions were entered into in the ordinary course of business, and such other transactions as may be required by the Exchange, from time to time; and
- (b) details of the outstanding balance(s) due to an affected listed issuer and its subsidiaries by the substantial shareholders and directors of the listed issuer (if any).

4.3 The details of the transactions to be disclosed shall include the following:-

- (a) the date(s) of the transaction(s);
- (b) the description of the transaction(s);
- (c) the parties to the transaction(s);
- (d) the relationship of the parties with the substantial shareholder or director of the affected listed issuer (where applicable);
- (e) the rationale for entering into the transaction(s);
- (f) the consideration for the transaction(s); and
- (g) whether the transaction(s) were on normal commercial terms.

4.4 The Monthly Reports must be submitted to the Exchange within 10 market days from the end of the month reported upon and must continue to be submitted until further notice from the Exchange.

4.5 The affected listed issuer must submit statutory declaration(s) duly executed by its board of directors or 2 directors duly authorized by the board of directors together with the Monthly Reports, in the prescribed format which is attached as Appendix PN4/2001-A.

5.0 Time schedule to regularise financial condition

- 5.1 An affected listed issuer must comply with the following time schedule:-
- (a) an affected listed issuer must make an announcement to the Exchange of a plan to regularise its financial condition within 6 months from the date of the First Announcement. This announcement must fulfil the requirements of the Exchange set out in paragraph 5.2 (“the requisite announcement”);
 - (b) an affected listed issuer which has made an announcement of a plan to regularise its financial condition must submit its plan to regularise its financial condition to the relevant authorities for approval, including the Commission (where applicable), within 2 months from the date of the requisite announcement or the date of the First Announcement (whichever applicable); and
 - (c) an affected listed issuer which has made the said announcement and submitted its plan to regularise its financial condition to the relevant authorities, in accordance with paragraphs 5.1(a) and (b), must obtain all approvals necessary for the implementation of such plan within 4 months from the date of submission of such plan for approval.
- 5.2 The requisite announcement must satisfy the following conditions:-
- (a) it must be a detailed plan, the implementation of which will enable an affected listed issuer to regularise its financial condition; and
 - (b) it must be announced by a merchant bank or a Member Company approved by the Commission to act as an adviser in the same manner as advisers under the Commission’s Policies and Guidelines on Issue/ Offer of Securities and include a timeline for the completion of the plan.
- 5.3 An affected listed issuer must ensure that prior to the making of the requisite announcement :-
- (a) all agreements to be entered into with third parties as part of the plan to regularise the financial condition, have been duly executed by all parties to such agreements; and
 - (b) where the plan involves a compromise or arrangement with the listed issuer’s creditors, an affected listed issuer has taken reasonable steps to procure the agreement-in-principle of such creditors.
- 5.4 An affected listed issuer must implement its plans to regularise its financial condition within the timeframes stipulated in paragraph 5.1 above.
- 5.5 An affected listed issuer which has made an announcement of a plan to regularise its financial condition on or prior to the date of this Practice Note and subsequently announces that its plan has been aborted, may be given a period of up to 6 months from the date of the First Announcement to make another requisite announcement of a plan to regularise its financial condition provided that the announcement to abort is made within 2 months from the date of the First Announcement.
- 5.6 The Exchange reserves the discretion to extend the timeframes given to an affected listed issuer pursuant to paragraph 5.1 above, upon its request, if the circumstances justify the same.
- 6.0 Monitoring accountant**
- 6.1 An affected listed issuer which fulfils one or more of the following criteria must appoint an independent accounting firm as a monitoring accountant (“the monitoring accountant”) within

2 weeks from the date of the First Announcement, to perform the functions set out in paragraph 6.2 below:-

- (a) the latest group audited accounts of the affected listed issuer are qualified in any one or more of the following respects:-
 - (i) the auditors were unable to determine that all relevant transactions have been recorded due to incomplete accounting records; or
 - (ii) the auditors were unable to obtain sufficient information and explanations from the directors with regard to the latest group audited consolidated accounts; or
- (b) the latest audited accounts have not been issued and the issuance has been delayed for more than 6 months from the date the audited accounts are due to be issued.

6.2 The functions of the monitoring accountant shall include the following:-

- (a) vetting and reviewing all payments and receipts of the affected listed issuer;
- (b) reviewing the movement of all assets of the affected listed issuer;
- (c) reporting on any legal action involving the affected listed issuer and its subsidiaries;
- (d) visiting the operations of an affected listed issuer, as and when considered necessary;
- (e) reporting on the above to the Exchange and the listed issuer once every 2 months, highlighting in particular, any irregularities; and
- (f) reporting any irregularity in the listed issuer to any other relevant regulator, including but not limited to the Commission and the Registrar of Companies, where appropriate.

6.3 None of the above provisions shall be construed to constitute the monitoring accountant as the agent of the Exchange.

7.0 Uplifting of suspension

7.1 The Exchange may uplift the suspension on trading of securities of an affected listed issuer which is suspended, upon its written request, provided that such listed issuer:-

- (a) is not subject to the appointment of a receiver and/or managers pursuant to paragraph 2.1(b);
- (b) is not subject to winding-up proceedings;
- (c) has not failed to issue its latest annual report for more than 12 months from the end of its financial year or has not failed to issue its quarterly report pursuant to paragraph 9.22 of the Listing Requirements for 2 consecutive financial quarters;
- (d) is able to provide adequate reasons, which in the opinion of the Exchange, would justify the uplifting of the suspension; and
- (e) it complies with the other requirements of the Exchange pursuant to this Practice Note.

8.0 Compliance with requirements

8.1 Any affected listed issuer which fails to comply with any of the obligations imposed on it by the Exchange under this Practice Note, may be regarded as a listed issuer whose financial condition does not warrant continued trading and/or listing.

9.0 Effective Date

9.1 This Practice Note takes effect on 15 February 2001.”

Appendix PN4/2001-A

STATUTORY DECLARATION

I/We,[NRIC No(s)/Passport No(s).....], the director(s) of[name of listed issuer] ("the listed issuer") do solemnly and sincerely declare as follows:-

- 1. The transactions reported in the Monthly Report for the month of constitute all of the related party transactions entered into by the listed issuer and its subsidiaries in the month concerned;
- 2. Save as disclosed, I/we affirm that all transactions entered into by the listed issuer and its subsidiaries in the month concerned were in the ordinary course of business of the listed issuer and its subsidiaries and on terms not more favourable than those generally available to the public;
- 3. Save as disclosed, to the best of my/our knowledge, the controlling shareholders or the directors have not benefited in any way from the transactions of the listed issuer and its subsidiaries; and
- 4. I/We have, at all times, in the month concerned, acted in the best interests of the listed issuer.

And I/we make this solemn declaration conscientiously believing the same to be true, and by virtue of the provisions of the Statutory Declarations Act 1960.

Subscribed and solemnly declared by the above-named

.....)
at)
in the State of)
thisday of.....,

Before me,

.....
(Signature of President of Sessions Court,
Magistrate, Commissioner for Oaths)"

[End of Annexure]

ANNEXURE PN29-B**PN10 Framework**
(paragraphs 1.2(b), 2.1 and 2.2)**[Reproduction of Paragraph 8.16]****“8.16 Level of operations**

- (1) The level of operations of a listed issuer must, in the opinion of the Exchange, be adequate to warrant continued trading and/or listing on the Official List.
- (2) A listed issuer whose level of operations is, in the opinion of the Exchange, inadequate to warrant continued trading on the Official List may have trading in its securities suspended. Any suspension imposed by the Exchange shall remain in force for a period of 6 months or such other period as may be determined by the Exchange.
- (3) If at the end of the period of suspension, the level of operations of the listed issuer is still inadequate to warrant continued listing, the Exchange may de-list such listed issuer.”

[Reproduction of Practice Note No 10/2001]

“KUALA LUMPUR STOCK EXCHANGE

PRACTICE NOTE NO 10/2001

LEVEL OF OPERATIONS

Issued in relation to paragraph 8.16 of the Listing Requirements;

And

Pursuant to paragraphs 2.08 and 2.19 of the Listing Requirements.

1.0 Introduction

1.1 A listed issuer must maintain a level of operations which, in the opinion of the Exchange, is adequate to warrant continued trading and/or listing on the Official List as set out under paragraph 8.16 of the Listing Requirements.

1.2 In this connection, this Practice Note enumerates the following in relation to a listed issuer:-

(a) circumstances which may be an indication that a listed issuer has a level of operations that is inadequate to warrant continued trading and/or listing on the Official List (such level of operations shall hereinafter be referred to as “inadequate level of operations”); and

(b) the obligations of such listed issuer.

1.3 It must be noted that the circumstances set out under paragraphs 2.1 and 2.2 of this Practice Note are by no means exhaustive.

1.4 Nothing in this Practice Note shall be read to restrict the generality of paragraph 8.16 of the Listing Requirements.

2.0 Determination of adequacy of level of operations

2.1 The following are some of the circumstances, the occurrence of any one of which, may lead the Exchange to determine a listed issuer as having inadequate level of operations pursuant to paragraph 8.16 of the Listing Requirements:-

(a) where the assets of the listed issuer on a consolidated basis consist of 70% or more of cash and/or short term investments (hereinafter referred to as "Cash Company"). As a minimum requirement, the listed issuer must make a determination as to whether it is or has become a Cash Company when it disposes its assets and/or business on a group basis or prepares its financial statements or accounts.

For the purpose of this paragraph, "short term investments" means investments which are by their nature readily realisable and intended to be held for 12 months or less including interests (equity or otherwise) in companies;

(b) the listed issuer has suspended or ceased:-

(i) all of its business or its major business; or

(ii) its entire or major operations,

for any reasons whatsoever including, amongst others, due to or as a result of:-

- (aa) the cancellation, loss or non-renewal of a licence, concession or such other rights necessary to conduct its business activities;
- (bb) the disposal of the listed issuer's business or major business; or
- (cc) a court order or judgment obtained against the listed issuer prohibiting the listed issuer from conducting its major operations on grounds of infringement of copyright of products etc.

For the purpose of this paragraph, "major" means such proportion that contributes or generates 70% or more of the listed issuer's revenue on a consolidated basis based on its latest annual audited accounts; or

- (c) the listed issuer has an insignificant business or operations. For the purpose of this paragraph, "insignificant business or operations " means business or operations which generates revenue on a consolidated basis that represents 5% or less of the issued and paid-up capital (excluding any redeemable preference shares) of the listed issuer (hereinafter referred to as "Capital") based on its latest annual audited accounts.

For the purpose of computation, where there is/are a change/changes to the Capital in that financial year, the weighted average Capital for that financial year shall be used. The weighted average Capital means the total amount of the Capital at the beginning of the financial year, adjusted by the amount of increase or reduction in the Capital during that financial year multiplied by a time-weighting factor. The time-weighting factor is the number of days that the specific Capital is outstanding as a proportion of the total number of days in that financial year.

Example - Weighted Average of Capital		Issued and Paid up Capital (RM)
1 January 2000	Balance	60,000,000
1 June 2000	Issue of 10,000,000 new shares for cash	70,000,000
1 Dec 2000	Issue of 12,000,000 new shares for cash	82,000,000
Computation of weighted average:		
$(60,000,000 \times 151/365) + (70,000,000 \times 183/365) + (82,000,000 \times 31/365) = 66,882,185$		

- 2.2 Where a listed issuer falls within any one of the circumstances set out in paragraph 2.1 above, the Exchange will make a determination as to whether the listed issuer has inadequate level of operations after consideration of all relevant facts and circumstances relating to the listed issuer's business and operations as well as the prevailing macro-economic conditions. If the Exchange determines the listed issuer as having inadequate level of operations, the Exchange will notify the listed issuer of this determination (hereinafter referred to as "the Notice").

3.0 Exceptions

- 3.1 Paragraph 2.1(a) shall not be applicable to companies whose activities are regulated by any written law relating to banking, finance companies or insurance and are subject to supervision by Bank Negara Malaysia, Member Companies, closed-end funds, property trust funds and infrastructure project companies which have not completed their infrastructure project(s).
- 3.2 Paragraph 2.1(c) shall not be applicable to closed-end funds, property trust funds and infrastructure project companies which have not completed and commenced operations on their infrastructure project(s).
- 3.3 For the purpose of paragraphs 3.1 and 3.2 above, "infrastructure project" shall be as defined in the Commission's Guidelines for Public Offerings of Securities of Infrastructure Project Companies.

4.0 Obligations of the listed issuer

- 4.1 A listed issuer that falls within any one of the circumstances set out in paragraph 2.1 must notify the Exchange in writing of the same immediately.
- 4.2 Where the Exchange determines a listed issuer as having inadequate level of operations and issues the Notice to the listed issuer (hereinafter referred to as "an affected listed issuer"), the affected listed issuer must comply with the following:-
- (a) provide such information as prescribed in paragraph 5.1 below;
 - (b) comply with the obligations set out in paragraph 6.1 below within the time frames stipulated therein; and
 - (c) do such other acts or things as may be required by the Exchange.

5.0 Disclosure obligations of the affected listed issuer

- 5.1 An affected listed issuer must comply with the following disclosure requirements. An affected listed issuer must:-
- (a) within 7 market days from the Notice announce the following to the Exchange (hereinafter referred to as the "Initial Announcement"):-
 - (i) that the affected listed issuer has inadequate level of operations and details relating to the same;
 - (ii) the obligations of an affected listed issuer pursuant to this Practice Note;
 - (iii) the consequences of non-compliance with the aforesaid obligations; and
 - (iv) the status of the affected listed issuer's proposal, if any, to ensure an adequate level of operations or the status of its endeavours/steps to formulate such a proposal, whichever is applicable, or where neither a proposal nor any endeavour to formulate such a proposal has been undertaken, an appropriate negative statement to such effect;
 - (b) announce the status of its proposal to ensure an adequate level of operations simultaneously with its quarterly report pursuant to paragraph 9.22 of the Listing Requirements and in any event not later than 2 months after the end of each quarter of a financial year until further notice from the Exchange; and

-
- (c) announce its compliance or non-compliance with a particular obligation imposed pursuant to this Practice Note, as and when such obligation becomes due.

6.0 Obligation to ensure adequate level of operations

6.1 Except as otherwise prescribed by the Exchange, an affected listed issuer must comply with the following obligations within the timeframes stipulated hereunder:-

- (a) an affected listed issuer must within 9 months from the date of the Initial Announcement make an announcement to the Exchange of a detailed proposal, the implementation of which will enable the affected listed issuer to ensure a level of operations that is adequate to warrant continued trading and/or listing on the Official List. This announcement must fulfil the requirements set out in paragraph 6.3 (hereinafter referred to as the "Requisite Announcement");
- (b) an affected listed issuer which has announced a detailed proposal to ensure an adequate level of operations must submit the same to the relevant authorities for approval within 2 months from the date of the Requisite Announcement or the date of the Initial Announcement (where the detailed proposal was made on or before the effective date of this Practice Note); and
- (c) an affected listed issuer which has submitted the detailed proposal to the relevant authorities, in accordance with subparagraph (b) above, must obtain all approvals necessary for the implementation of such detailed proposal within 4 months from the date of submission of such detailed proposal for approval.

6.2 The Exchange reserves the discretion to extend the timeframes given to the affected listed issuer pursuant to paragraph 6.1 above, upon its request, if the circumstances justify the same.

6.3 In respect of the Requisite Announcement, an affected listed issuer must ensure that it is made by a merchant bank or a Member Company approved by the Commission to act as an adviser in the same manner as advisers under the Commission's Policies and Guidelines on Issue/Offer of Securities and include a timeline for the completion of the proposal. Prior to the making of the Requisite Announcement, the listed issuer must ensure that all agreements to be entered into with third parties as part of the proposal have been duly executed by all parties to such agreements.

7.0 Suspension and de-listing

7.1 If an affected listed issuer fails to comply with any of the obligations imposed on it by the Exchange pursuant to this Practice Note, the Exchange may have trading in the affected listed issuer's securities suspended and subsequently de-list the affected listed issuer.

8.0 Effective Date

8.1 This Practice Note takes effect on 1 July 2001."

[End of Annexure]

ANNEXURE PN29-C**Original PN16 Framework**
(paragraphs 1.2(c), 3.1 and 3.2)**[Reproduction of Paragraph 8.14B]****“8.14B Cash Companies**

- (1) A listed issuer that is considered a “Cash Company” by the Exchange must comply with such requirements as may be prescribed by the Exchange, failing which the Exchange may de-list such listed issuer.
- (2) A listed issuer whose assets on a consolidated basis, consist of 70% or more of cash or short term investments, or a combination of both, must immediately notify the Exchange of the same in writing (referred to as “the Cash Criterion” in this Part E). The Exchange will make a determination as to whether such listed issuer should be considered a Cash Company pursuant to subparagraph (1) above. A listed issuer considered as a Cash Company by the Exchange will be notified by the Exchange (referred to as “the Notice” in this Part E).
- (3) For the purposes of subparagraph (2) above, the following shall apply:-
 - (a) a listed issuer must, as a minimum requirement, make a determination as to whether it triggers the Cash Criterion when it disposes its assets or business on a group basis or prepares its financial statements or accounts; and
 - (b) “short term investments” means investments which are by their nature readily realisable and intended to be held for 12 months or less including interests (equity or otherwise) in companies.
- (4) A Cash Company must comply with the following additional requirements:-
 - (a) regularise its condition in the following manner:-
 - (i) submit a proposal to regularise its condition to the relevant authorities for approval or, where the relevant authorities’ approvals are not required, obtain all other approvals necessary for the implementation of the proposal within such timeframe as may be stipulated by the Exchange; and
 - (ii) implement its proposal to regularise its condition within the timeframe stipulated by the relevant authorities or where no timeframe has been stipulated or allowed by the relevant authorities, within the timeframe stipulated by the Exchange,
 - (b) provide such information as may be prescribed by the Exchange from time to time for public release; and
 - (c) do such other acts or things as may be required by the Exchange.
- (5) For the purpose of subparagraph (4)(a) above, a “proposal to regularise its condition” refers to a proposal, the implementation of which will result in the Cash Company no longer being considered a Cash Company by the Exchange (referred to as “the Proposal” in this Part E).
- (6) A Cash Company which fails to comply with subparagraph (4)(a) above or whose Proposal is rejected by the relevant authorities, may have its listed securities suspended and subsequently de-listing procedures commenced against the Cash Company.

- (7) Subparagraphs (1) and (2) above shall not be applicable to listed issuers whose activities are regulated by any written law relating to banking, finance companies or insurance and are subject to supervision by Bank Negara Malaysia, Participating Organisations, closed-end funds, real estate investment trust, infrastructure project companies which have not completed their infrastructure project(s) and such other category of listed issuers as may be stipulated by the Exchange. For the purpose of this subparagraph, "infrastructure project" shall be as defined in the Commission's Policies and Guidelines on Issue/Offer of Securities."

[Reproduction of Practice Note No 16/2005]

BURSA MALAYSIA SECURITIES BERHAD

PRACTICE NOTE NO. 16/2005

CASH COMPANIES

Issued in relation to paragraphs 8.14B, 16.02 and 16.09 of the Listing Requirements;

And

Pursuant to paragraphs 2.08 and 2.19 of the Listing Requirements.

1.0 Introduction

- 1.1 Paragraph 8.14B(1) of the Listing Requirements states that a listed issuer that is considered a Cash Company must comply with such requirements as may be prescribed by the Exchange.
- 1.2 In this connection, this Practice Note sets out the requirements that must be complied with by a Cash Company.
- 1.3 Nothing in this Practice Note shall be read to restrict the generality of paragraph 8.14B of the Listing Requirements.
- 1.4 The provisions of this Practice Note are in amplification and not in derogation of the obligations of a listed issuer as contained in the Listing Requirements.

2.0 Disclosure obligations of a Cash Company

- 2.1 A Cash Company must comply with the following disclosure requirements. A Cash Company must:-
 - (a) within 7 market days from the Notice (as defined in paragraph 8.14B(2)) announce the following to the Exchange (hereinafter referred to as the "Initial Announcement"):-
 - (i) that the listed issuer is a Cash Company;
 - (ii) the obligations of a Cash Company pursuant to this Practice Note;
 - (iii) the consequences of non-compliance with the aforesaid obligations; and
 - (iv) the status of the Cash Company's proposal to comply with the obligations set out in paragraph 8.14B(4)(a) of the Listing Requirements, or the status of its endeavours/steps to formulate such a proposal, whichever is applicable, or where neither a proposal nor any endeavour to formulate such a proposal has been undertaken, an appropriate negative statement to such effect;
 - (b) announce the status of its proposal referred to in subparagraph (a)(iv) above and the number of months to the end of the relevant timeframes referred to in paragraph 3.1 or 3.2 below, as may be applicable, simultaneously with the announcement of its quarterly report pursuant to paragraph 9.22 of the Listing Requirements and in any

event not later than 2 months after the end of each quarter of a financial year until further notice from the Exchange; and

- (c) announce its compliance or non-compliance with a particular obligation imposed pursuant to this Practice Note on an immediate basis.

3.0 Obligation to Regularise

3.1 A Cash Company must submit the Proposal, as defined in paragraph 8.14B(5) of the Listing Requirements, to the relevant authorities for approval, or where the relevant authorities' approvals are not required, obtain all other approvals necessary for the implementation of the Proposal within 12 months from the date of the Initial Announcement.

3.2 A Cash Company must also implement the Proposal within the timeframe stipulated by the relevant authorities or where no timeframe has been stipulated or allowed by the relevant authorities, within the timeframe stipulated by the Exchange.

4.0 Effective Date

4.1 This Practice Note takes effect on 3 January 2005."

[End of Annexure]

ANNEXURE PN29-D**Original PN17 Framework**
(paragraphs 1.2(d), 3.1 and 3.2)**[Reproduction of Paragraph 8.14C]****“8.14C Financial condition and level of operations**

- (1) The financial condition and level of operations of a listed issuer on a consolidated basis must, in the opinion of the Exchange, warrant continued trading and/or listing on the Official List, failing which the Exchange may de-list such listed issuer.
- (2) The Exchange may prescribe certain criteria in relation to the financial condition and level of operations of a listed issuer (referred to as “the Prescribed Criteria” in this Part E), the fulfilment of one or more of which would require the listed issuer (referred to as “the Affected Listed Issuer” in this Part E) to comply with the following additional requirements:-
 - (a) regularize its condition in the following manner (referred to as “the Obligation to Regularise” in this Part E):-
 - (i) submit a plan to regularize its condition to the relevant authorities for approval or, where the relevant authorities’ approvals are not required, obtain all other approvals necessary for the implementation of the plan within such timeframe as may be stipulated by the Exchange (referred to as “Submission Timeframe” in this Part E); and
 - (ii) implement its plan to regularize its condition within the timeframe stipulated by the relevant authorities or where no timeframe has been stipulated or allowed by the relevant authorities, within the timeframe stipulated by the Exchange (referred to as “Implementation Timeframe” in this Part E),

(the Submission Timeframe and Implementation Timeframe shall be referred to collectively as “the Stipulated Timeframes” in this Part E);
 - (b) provide such information as may be prescribed by the Exchange from time to time for public release; and
 - (c) do such other acts or things as may be required by the Exchange.
- (3) For the purpose of subparagraph (2)(a) above, a “plan to regularise its condition” refers to a plan, the implementation of which will result in the Affected Listed Issuer no longer triggering any of the Prescribed Criteria (referred to as “the Regularisation Plan” in this Part E).
- (4) An Affected Listed Issuer which fails to comply with the Obligation to Regularise shall have all its listed securities suspended from trading on the 5th market day after expiry of the Submission Timeframe or Implementation Timeframe, as the case may be, and de-listing procedures shall be commenced against such Affected Listed Issuer.
- (5) Where an Affected Listed Issuer has submitted its Regularisation Plan to the relevant authorities for approval prior to the expiry of the Submission Timeframe but whose Regularisation Plan is rejected by the relevant authorities, the following shall apply:-
 - (a) if the rejection takes place after the expiry of the Submission Timeframe, the Affected Listed Issuer shall have all its listed securities suspended from trading on the 5th market day after the Affected Listed Issuer’s announcement of the relevant

-
- authorities' rejection and de-listing procedures shall be commenced against such Affected Listed Issuer; or
- (b) if the rejection takes place prior to the expiry of the Submission Timeframe, the Affected Listed Issuer shall have all its listed securities suspended from trading on the 5th market day after expiry of the Submission Timeframe and de-listing procedures shall be commenced against such Affected Listed Issuer unless either:-
- (i) the Affected Listed Issuer submits a new or revised Regularisation Plan to the relevant authorities for approval within the Submission Timeframe; or
 - (ii) the Affected Listed Issuer appeals against the rejection of the relevant authorities and the appeal is pending upon expiry of the Submission Timeframe.
- (6) In the case of an Affected Listed Issuer falling within the circumstances described under subparagraph (5)(b)(ii) above and the appeal lodged by the Affected Listed Issuer with the relevant authorities is unsuccessful, the Affected Listed Issuer shall have all its listed securities suspended from trading on the 5th market day after the Affected Listed Issuer's announcement of the relevant authorities' rejection of the appeal and de-listing procedures shall be commenced against such Affected Listed Issuer."

[Reproduction of Practice Note No 17/2005]

BURSA MALAYSIA SECURITIES BERHAD

PRACTICE NOTE NO. 17/2005

CRITERIA AND OBLIGATIONS PURSUANT TO PARAGRAPH 8.14C OF THE LISTING REQUIREMENTS

Issued in relation to paragraphs 8.14C, 16.02 and 16.09 of the Listing Requirements;

And

Pursuant to paragraph 2.08 and 2.19 of the Listing Requirements.

1.0 Introduction

1.1 This Practice Note sets out, amongst others, the following:-

- (a) the criteria in relation to the financial condition and level of operations of a listed issuer, the fulfillment of one or more of which will require a listed issuer to comply with the provisions of this Practice Note (a listed issuer which fulfils one or more of the aforesaid criteria shall hereinafter be referred to as “an Affected Listed Issuer”); and
- (b) the requirements that must be complied with by an Affected Listed Issuer.

1.2 Nothing in this Practice Note shall be read to restrict the generality of paragraph 8.14C of the Listing Requirements.

1.3 The provisions of this Practice Note are in amplification and not in derogation of the obligations of a listed issuer as contained in the Listing Requirements.

2.0 Criteria

2.1 Pursuant to paragraph 8.14C(2) of the Listing Requirements, the Exchange prescribes the following criteria, the fulfillment of one or more of which will require an Affected Listed Issuer to comply with the provisions of this Practice Note :-

- (a) deficit in the adjusted shareholders' equity of the listed issuer on a consolidated basis;
- (b) receivers and/or managers have been appointed over the property of the listed issuer, or over the property of its major subsidiary or major associated company which property accounts for at least 70% of the total assets employed of the listed issuer on a consolidated basis;
- (c) the auditors have expressed adverse or disclaimer opinion in respect of the listed issuer's going concern, in its latest audited accounts;
- (d) the listed issuer has suspended or ceased:-
 - (i) all of its business or its major business; or

- (ii) its entire or major operations,
for any reasons whatsoever including, amongst others, due to or as a result of:-
 - (aa) the cancellation, loss or non-renewal of a licence, concession or such other rights necessary to conduct its business activities;
 - (bb) the disposal of the listed issuer's business or major business; or
 - (cc) a court order or judgment obtained against the listed issuer prohibiting the listed issuer from conducting its major operations on grounds of infringement of copyright of products etc; or
- (e) the listed issuer has an insignificant business or operations.

2.2 For the purposes of this Practice Note:-

- (a) "adjusted shareholders' equity" is defined as the residual interest in the assets of a listed issuer on a consolidated basis after deducting all its liabilities, based on the listed issuer's latest audited or unaudited accounts. The components of adjusted shareholders' equity will include the following:
 - (i) share capital;
 - (ii) share premium account;
 - (iii) capital redemption reserves;
 - (iv) revaluation reserves;
 - (v) translation reserves;
 - (vi) retained profit/accumulated loss; and
 - (vii) other reserves and/or any other components as determined by the Exchange.

For the purposes of this definition, redeemable preference shares and negative goodwill or reserves on consolidation shall be excluded from the determination of adjusted shareholders' equity. In addition, in determining the components of "other reserves and/or any other components", in the absence of any provisions in the approved accounting standards and/or the Companies Act 1965, the Exchange will take into consideration the application of the generally accepted accounting principles and the best current practices and the Exchange's treatment of this component shall prevail;

- (b) "total assets employed" shall be based on the listed issuer's latest audited or unaudited accounts;
- (c) "a major subsidiary" means a subsidiary which contributes 70% or more of the profits before tax or total assets employed of the listed issuer on a consolidated basis.
- (d) in relation to paragraph 2.1(d), "major" means such proportion that contributes or generates 70% or more of the listed issuer's revenue on a consolidated basis based on its latest annual audited or unaudited accounts; and
- (e) "insignificant business or operations" means business or operations which generates

revenue on a consolidated basis that represents 5% or less of the issued and paid-up capital (excluding any redeemable preference shares) of the listed issuer (hereinafter referred to as "Capital") based on its latest annual audited or unaudited accounts.

For the purpose of computation, the following shall apply:-

- (i) "revenue on a consolidated basis" shall comprise of the revenue of the listed issuer, its subsidiaries, as well as revenue from the listed issuer's associated companies, calculated on a proportionate basis, based on the listed issuer's equity holding in the associated companies; and
- (ii) where there is/are a change/changes to the Capital in that financial year, the weighted average Capital for that financial year shall be used. The weighted average Capital means the total amount of the Capital at the beginning of the financial year, adjusted by the amount of increase or reduction in the Capital during that financial year multiplied by a time-weighting factor. The time-weighting factor is the number of days that the specific Capital is outstanding as a proportion of the total number of days in that financial year.

Example – Weighted Average of Capital for financial year ended 31 December 2xx1

		Issued and Paid up Capital (RM)
1 January 2xx1	Balance	60,000,000
1 June 2xx1	Issue of 10,000,000 new shares for cash	70,000,000
1 Dec 2xx1	Issue of 12,000,000 new shares for cash	82,000,000

Computation of weighted average:

$$(60,000,000 \times 151/365) + (70,000,000 \times 183/365) + (82,000,000 \times 31/365) = 66,882,185$$

- 2.3 Paragraph 2.1 (e) shall not be applicable to closed-end funds, real estate investment trust and infrastructure project companies which have not completed and commenced operations on their infrastructure project(s). For the purpose of this paragraph, "infrastructure project" shall be as defined in the Commission's Policies and Guidelines on Issue/Offer of Securities.

3.0 Disclosure obligations of the Affected Listed Issuer

- 3.1 Pursuant to paragraph 8.14C(2)(b) of the Listing Requirements, an Affected Listed Issuer must comply with the following disclosure requirements:-

- (a) within 7 market days from the date a listed issuer fulfils one or more of the criteria prescribed pursuant to paragraph 8.14C(2) of the Listing Requirements, announce the following ("the First Announcement"):-
 - (i) the listed issuer is an Affected Listed Issuer pursuant to this Practice Note;
 - (ii) the obligations of the listed issuer pursuant to this Practice Note;
 - (iii) the consequences of non-compliance with such obligations; and

-
- (iv) the status of the listed issuer's plan to comply with the Obligation to Regularise (as defined in paragraph 8.14C(2)(a) of the Listing Requirements) or the status of its endeavours to formulate such a plan, whichever is applicable, or where neither a plan nor any endeavour to formulate such a plan has been undertaken, an appropriate negative statement to such effect;
- (b) announce the status of its plan as referred to in paragraph (a)(iv) above and the number of months to the end of the relevant timeframes referred to in paragraph 4.1 or 4.2 below, as may be applicable, on a monthly basis (hereinafter referred to as the "Monthly Announcement") until further notice from the Exchange; and
- (c) announce its compliance or non-compliance with a particular obligation imposed pursuant to this Practice Note on an immediate basis.
- 3.2 The Monthly Announcements must be made on the first market day of each month beginning with the month following the date of the First Announcement.
- 4.0 Obligation to Regularise**
- 4.1 An Affected Listed Issuer must submit the Regularisation Plan as defined in paragraph 8.14C(3) of the Listing Requirements to the relevant authorities for approval or, where the relevant authorities' approvals are not required, obtain all other approvals necessary for the implementation of the Regularisation Plan within 8 months from the date of the First Announcement (i.e. the Submission Timeframe).
- 4.2 An Affected Listed Issuer must implement the Regularisation Plan within the timeframe stipulated by the relevant authorities or where no timeframe has been stipulated or allowed by the relevant authorities, within the timeframe stipulated by the Exchange (i.e. the Implementation Timeframe).
- 5.0 Effective Date**
- 5.1 This Practice Note takes effect on 3 January 2005.

[End of Annexure]

ANNEXURE PN29-E**Amended PN16 Framework**
(paragraphs 1.2(e), 4.1, 4.2 and 4.3)**[Reproduction of Paragraph 8.14B]****“8.14B Cash Companies**

- (1) A listed issuer that is considered a “Cash Company” by the Exchange must comply with such requirements as may be prescribed by the Exchange, failing which the Exchange may de-list such listed issuer.
- (2) A listed issuer whose assets on a consolidated basis, consist of 70% or more of cash or short term investments, or a combination of both, must immediately notify the Exchange of the same in writing (referred to as “the Cash Criterion” in this Part E). The Exchange will make a determination as to whether such listed issuer should be considered a Cash Company pursuant to subparagraph (1) above. A listed issuer considered as a Cash Company by the Exchange will be notified by the Exchange (referred to as “the Notice” in this Part E).
- (3) For the purposes of subparagraph (2) above, the following shall apply:-
 - (a) a listed issuer must, as a minimum requirement, make a determination as to whether it triggers the Cash Criterion when it disposes its assets or business on a group basis or prepares its financial statements or accounts; and
 - (b) “short term investments” means investments which are by their nature readily realisable and intended to be held for 12 months or less including interests (equity or otherwise) in companies.
- (4) A Cash Company must comply with the following additional requirements:-
 - (a) regularize its condition in the following manner:-
 - (i) submit a proposal to regularize its condition to the Commission, and the other relevant authorities, for approval (collectively referred to as the “Approving Authority” in this Part E) within such timeframe as may be stipulated by the Exchange; and
 - (ii) implement its proposal to regularize its condition within the timeframe stipulated by the relevant Approving Authority;
 - (b) provide such information as may be prescribed by the Exchange from time to time for public release; and
 - (c) do such other acts or things as may be required by the Exchange.
- (5) For the purpose of subparagraph (4)(a) above, a “proposal to regularise its condition” refers to a proposal that is substantive and falls within the ambit of section 212 of the CMSA (referred to as “the Proposal” in this Part E).
- (6) A Cash Company which fails to comply with subparagraph (4)(a) above or whose Proposal is rejected by the Approving Authority, may have its listed securities suspended and subsequently de-listing procedures commenced against the Cash Company.

- (7) Subparagraphs (1) and (2) above shall not be applicable to listed issuers whose activities are regulated by any written law relating to banking, finance companies or insurance and are subject to supervision by Bank Negara Malaysia, Participating Organisations, closed-end funds, real estate investment trusts, exchange traded funds, infrastructure project companies which have not completed their infrastructure project(s) and such other category of listed issuers as may be stipulated by the Exchange. For the purpose of this subparagraph, "infrastructure project" shall be as defined in the Commission's Guidelines on the Offering of Equity and Equity-Linked Securities.
- (8) Where a Cash Company has completed the implementation of its Proposal, it must submit an application to the Exchange together with all the necessary documentary evidence to show that it is no longer a Cash Company."

[Reproduction of Practice Note No. 16/2005]

“BURSA MALAYSIA SECURITIES BERHAD

PRACTICE NOTE NO. 16/2005

CASH COMPANIES

Issued in relation to paragraphs 8.14B, 16.02 and 16.09 of the Listing Requirements;

And

Pursuant to paragraphs 2.08 and 2.19 of the Listing Requirements.

1.0 Introduction

- 1.1 Paragraph 8.14B(1) of the Listing Requirements states that a listed issuer that is considered a Cash Company must comply with such requirements as may be prescribed by the Exchange.
- 1.2 In this connection, this Practice Note sets out the requirements that must be complied with by a Cash Company.
- 1.3 Nothing in this Practice Note shall be read to restrict the generality of paragraph 8.14B of the Listing Requirements.
- 1.4 The provisions of this Practice Note are in amplification and not in derogation of the obligations of a listed issuer as contained in the Listing Requirements.

2.0 Disclosure obligations of a Cash Company

- 2.1 A Cash Company must comply with the following disclosure requirements. A Cash Company must:-
- (a) immediately upon receipt of the Notice (as defined in paragraph 8.14B(2)) announce the following to the Exchange (hereinafter referred to as the "Initial Announcement"):-
 - (i) that the listed issuer is a Cash Company;
 - (ii) the obligations of a Cash Company pursuant to this Practice Note;
 - (iii) the consequences of non-compliance with the aforesaid obligations; and
 - (iv) the status of the Cash Company's proposal to comply with the obligations set out in paragraph 8.14B(4)(a) of the Listing Requirements, or the status of its endeavours/steps to formulate such a proposal, whichever is applicable, or where neither a proposal nor any endeavour to formulate such a proposal has been undertaken, an appropriate negative statement to such effect;
 - (b) announce the status of its proposal referred to in subparagraph (a)(iv) above and the number of months to the end of the relevant timeframes referred to in paragraph 3.1 or 3.2 below, as may be applicable, simultaneously with the announcement of its quarterly report pursuant to paragraph 9.22 of the Listing Requirements and in any

event not later than 2 months after the end of each quarter of a financial year until further notice from the Exchange;

- (c) announce its compliance or non-compliance with a particular obligation imposed pursuant to this Practice Note on an immediate basis; and
- (d) announce details of the Proposal as referred to in paragraph 8.14B(5) of the Listing Requirements which announcement must fulfill the requirements set out in paragraph 2.2 below (hereinafter referred to as “the Requisite Announcement”).

2.2 The Requisite Announcement must satisfy the following conditions:-

- (a) the announcement must contain details of the Proposal and a timeline for the complete implementation of the Proposal; and
- (b) it must be announced by a corporate finance adviser that may act as a principal adviser under the Commission’s Guidelines on Principal Advisers for Corporate Proposals.

2.3 A Cash Company must ensure that prior to the making of the Requisite Announcement, all agreements to be entered into with third parties as part of the Proposal, have been duly executed by all parties to such agreements.

3.0 Obligation to Regularise

3.1 A Cash Company must submit a Proposal, as referred to in paragraph 8.14B(5) of the Listing Requirements, to the relevant Approving Authority as referred to in paragraph 8.14B(4)(a)(i) of the Listing Requirements for approval within 12 months from the date of the Initial Announcement.

3.2 A Cash Company must also implement the Proposal within the timeframe stipulated by the relevant Approving Authority.

4.0 Effective Date

4.1 This Practice Note takes effect on 3 January 2005.

[End of Annexure]

ANNEXURE PN29-F**Amended PN17 Framework**
(paragraphs 1.2(f), 4.1, 4.2 and 4.3)**[Reproduction of Paragraph 8.14C]****“8.14C Financial condition and level of operations**

- (1) The financial condition and level of operations of a listed issuer on a consolidated basis must, in the opinion of the Exchange, warrant continued trading and/or listing on the Official List, failing which the Exchange may de-list such listed issuer.
- (2) The Exchange may prescribe certain criteria in relation to the financial condition and level of operations of a listed issuer (referred to as “the Prescribed Criteria” in this Part E), the fulfilment of one or more of which would require the listed issuer (referred to as “the Affected Listed Issuer” in this Part E) to comply with the following additional requirements:-
 - (a) regularise its condition in the following manner (referred to as “the Obligation to Regularise” in this Part E):-
 - (i) submit a plan to regularise its condition to the Commission, and the other relevant authorities for approval, (collectively referred to as the “Approving Authority” in this Part E) within such timeframe as may be stipulated by the Exchange (referred to as “Submission Timeframe” in this Part E); and
 - (ii) implement its plan to regularise its condition within the timeframe stipulated by the relevant Approving Authority (referred to as “Implementation Timeframe” in this Part E),

(the Submission Timeframe and Implementation Timeframe shall be referred to collectively as “the Stipulated Timeframes” in this Part E);
 - (b) provide such information as may be prescribed by the Exchange from time to time for public release; and
 - (c) do such other acts or things as may be required by the Exchange.
- (3) For the purpose of subparagraph (2)(a) above, a “plan to regularise its condition” refers to a plan that is substantive and falls within the ambit of section 212 of the CMSA (referred to as “the Regularisation Plan” in this Part E).
- (4) An Affected Listed Issuer which fails to comply with the Obligation to Regularise shall have all its listed securities suspended from trading on the 5th market day after expiry of the Submission Timeframe or Implementation Timeframe, as the case may be, and de-listing procedures shall be commenced against such Affected Listed Issuer.
- (5) Where an Affected Listed Issuer has submitted its Regularisation Plan to the Approving Authority for approval prior to the expiry of the Submission Timeframe but whose Regularisation Plan is rejected by the Approving Authority, the following shall apply:-
 - (a) if the rejection takes place after the expiry of the Submission Timeframe, the Affected Listed Issuer shall have all its listed securities suspended from trading on the 5th market day after the Affected Listed Issuer’s announcement of the Approving Authority’s rejection and de-listing procedures shall be commenced against such Affected Listed Issuer; or

- (b) if the rejection takes place prior to the expiry of the Submission Timeframe, the Affected Listed Issuer shall have all its listed securities suspended from trading on the 5th market day after expiry of the Submission Timeframe and de-listing procedures shall be commenced against such Affected Listed Issuer unless either:-
- (i) the Affected Listed Issuer submits a new or revised Regularisation Plan to the Approving Authority for approval within the Submission Timeframe; or
 - (ii) the Affected Listed Issuer appeals against the rejection of the Approving Authority and the appeal is pending upon expiry of the Submission Timeframe.
- (6) In the case of an Affected Listed Issuer falling within the circumstances described under subparagraph (5)(b)(ii) above and the appeal lodged by the Affected Listed Issuer with the Approving Authority is unsuccessful, the Affected Listed Issuer shall have all its listed securities suspended from trading on the 5th market day after the Affected Listed Issuer's announcement of the Approving Authority's rejection of the appeal and de-listing procedures shall be commenced against such Affected Listed Issuer.
- (7) Where an Affected Listed Issuer has completed the implementation of its Regularisation Plan, it must submit an application to the Exchange together with all the necessary documentary evidence to show that it no longer triggers any of the Prescribed Criteria."

[Reproduction of Practice Note No. 17/2005]

“BURSA MALAYSIA SECURITIES BERHAD

PRACTICE NOTE NO. 17/2005

CRITERIA AND OBLIGATIONS PURSUANT TO PARAGRAPH 8.14C OF THE LISTING REQUIREMENTS

Issued in relation to paragraphs 8.14C, 16.02 and 16.09 of the Listing Requirements;
And
Pursuant to paragraph 2.08 and 2.19 of the Listing Requirements.

1.0 Introduction

1.1 This Practice Note sets out, amongst others, the following:-

- (a) the criteria in relation to the financial condition and level of operations of a listed issuer, the fulfillment of one or more of which will require a listed issuer to comply with the provisions of this Practice Note (a listed issuer which fulfils one or more of the aforesaid criteria shall hereinafter be referred to as “an Affected Listed Issuer”); and
- (b) the requirements that must be complied with by an Affected Listed Issuer.

1.2 Nothing in this Practice Note shall be read to restrict the generality of paragraph 8.14C of the Listing Requirements.

1.3 The provisions of this Practice Note are in amplification and not in derogation of the obligations of a listed issuer as contained in the Listing Requirements.

2.0 Criteria

2.1 Pursuant to paragraph 8.14C(2) of the Listing Requirements, the Exchange prescribes the following criteria (hereinafter referred to as the “Prescribed Criteria”), the fulfillment of one or more of which will require a listed issuer to comply with the provisions of paragraph 8.14C and this Practice Note :-

- (a) the shareholders’ equity of the listed issuer on a consolidated basis is equal to or less than 25% of the issued and paid-up capital of the listed issuer and such shareholders’ equity is less than the minimum issued and paid-up capital as required under paragraph 8.16A(1) of the Listing Requirements ;
- (b) receivers and/or managers have been appointed over the asset of the listed issuer, its subsidiary or associated company which asset accounts for at least 50% of the total assets employed of the listed issuer on a consolidated basis;
- (c) a winding up of a listed issuer’s subsidiary or associated company which accounts for at least 50% of the total assets employed of the listed issuer on a consolidated basis;
- (d) the auditors have expressed an adverse or disclaimer opinion in the listed issuer’s latest audited accounts;

-
- (e) the auditors have expressed a modified opinion with emphasis on the listed issuer's going concern in the listed issuer's latest audited accounts and the shareholders' equity of the listed issuer on a consolidated basis is equal to or less than 50% of the issued and paid-up capital of the listed issuer;
 - (f) a default in payment by a listed issuer, its major subsidiary or major associated company, as the case may be, as announced by a listed issuer pursuant to Practice Note No 1/2001 and the listed issuer is unable to provide a solvency declaration to the Exchange.
 - (g) the listed issuer has suspended or ceased:-
 - (i) all of its business or its major business; or
 - (ii) its entire or major operations,for any reasons whatsoever including, amongst others, due to or as a result of:-
 - (aa) the cancellation, loss or non-renewal of a licence, concession or such other rights necessary to conduct its business activities;
 - (bb) the disposal of the listed issuer's business or major business; or
 - (cc) a court order or judgment obtained against the listed issuer prohibiting the listed issuer from conducting its major operations on grounds of infringement of copyright of products etc; or
 - (h) the listed issuer has an insignificant business or operations.

2.2 For the purposes of this Practice Note, unless the context otherwise requires:-

- (a) the components of "shareholders' equity" shall be as prescribed under the approved accounting standards of the Malaysian Accounting Standards Board;
- (b) "total assets employed" shall be based on the listed issuer's latest audited or unaudited accounts ;
- (c) in relation to paragraph 2.1(g), "major" means such proportion that contributes or generates 70% or more of the listed issuer's revenue on a consolidated basis based on its latest annual audited or unaudited accounts ; and
- (d) "insignificant business or operations" means business or operations which generates revenue on a consolidated basis that represents 5% or less of the issued and paid-up capital (excluding any redeemable preference shares) of the listed issuer (hereinafter referred to as "Capital") based on its latest annual audited or unaudited accounts .

For the purpose of computation, the following shall apply:-

- (i) "revenue on a consolidated basis" shall comprise of the revenue of the listed issuer, its subsidiaries, as well as revenue from the listed issuer's associated companies, calculated on a proportionate basis, based on the listed issuer's equity holding in the associated companies; and
- (ii) where there is/are a change/changes to the Capital in that financial year, the weighted average Capital for that financial year shall be used. The weighted average Capital means the total amount of the Capital at the beginning of the financial year, adjusted by the amount of increase or reduction in the Capital

during that financial year multiplied by a time-weighting factor. The time-weighting factor is the number of days that the specific Capital is outstanding as a proportion of the total number of days in that financial year.

Example - Weighted Average of Capital for financial year ended 31 December 2xx1

		Issued and Paid up Capital (RM)
1 January 2xx1	Balance	60,000,000
1 June 2xx1	Issue of 10,000,000 new shares for cash	70,000,000
1 Dec 2xx1	Issue of 12,000,000 new shares for cash	82,000,000

Computation of weighted average:

$$(60,000,000 \times 151/365) + (70,000,000 \times 183/365) + (82,000,000 \times 31/365) = 66,882,185$$

- 2.3 Paragraph 2.1 (h) shall not be applicable to closed-end funds, real estate investment trusts, exchange traded funds and infrastructure project companies which have not completed and commenced operations on their infrastructure project(s). For the purpose of this paragraph, "infrastructure project" shall be as defined in the Commission's Guidelines on the Offering of Equity and Equity-Linked Securities.

3.0 Disclosure obligations of the Affected Listed Issuer

- 3.1 Pursuant to paragraph 8.14C(2)(b) of the Listing Requirements, an Affected Listed Issuer must comply with the following disclosure requirements:-

- (a) announce the following, on an immediate basis (hereinafter referred to as "the First Announcement") upon the Affected Listed Issuer fulfilling one or more of the Prescribed Criteria:-
- (i) that the listed issuer is an Affected Listed Issuer pursuant to this Practice Note;
 - (ii) the obligations of the listed issuer pursuant to this Practice Note;
 - (iii) the consequences of non-compliance with such obligations; and
 - (iv) the status of the listed issuer's plan to comply with the Obligation to Regularise (as defined in paragraph 8.14C(2)(a) of the Listing Requirements) or the status of its endeavours to formulate such a plan, whichever is applicable, or where neither a plan nor any endeavour to formulate such a plan has been undertaken, an appropriate negative statement to such effect;
- (b) announce the status of its plan as referred to in paragraph (a)(iv) above and the number of months to the end of the relevant timeframes referred to in paragraph 4.1 or 4.2 below, as may be applicable, on a monthly basis (hereinafter referred to as the "Monthly Announcement") until further notice from the Exchange;
- (c) announce its compliance or non-compliance with a particular obligation imposed pursuant to this Practice Note on an immediate basis; and

- (d) announce details of the Regularisation Plan as referred to in paragraph 8.14C(3) of the Listing Requirements which announcement must fulfill the requirements set out in paragraph 3.1A below (hereinafter referred to as "the Requisite Announcement").

3.2 The Requisite Announcement must satisfy the following conditions:-

- (a) the announcement must contain details of the Regularisation Plan and a timeline for the complete implementation of the Regularisation Plan; and
- (b) it must be announced by a corporate finance adviser that may act as a principal adviser under the Commission's Guidelines on Principal Advisers for Corporate Proposals 3.1B. An Affected Listed Issuer must ensure that prior to the making of the Requisite Announcement:-
- (i) all agreements to be entered into with third parties as part of the Regularisation Plan, have been duly executed by all parties to such agreements; and
- (ii) where the Regularisation Plan involves a compromise or arrangement with the Affected Listed Issuer's creditors, the Affected Listed Issuer has taken reasonable steps to procure the agreement-in-principle of such creditors.

3.3 The Monthly Announcements must be made on the first market day of each month beginning with the month following the date of the First Announcement.

4.0 Obligation to Regularise

4.1 An Affected Listed Issuer must submit a Regularisation Plan as referred to in paragraph 8.14C(3) of the Listing Requirements to the Approving Authority as referred to in paragraph 8.14C(2)(a)(i) of the Listing Requirement for approval within 8 months from the date of the First Announcement (i.e. the Submission Timeframe)

4.2 An Affected Listed Issuer must implement Regularisation Plan within the timeframe stipulated by the relevant Approving Authority.

5.0 Effective Date

5.1 This Practice Note takes effect on 3 January 2005."

[End of Annexure]